

SECTION A – Core**Instructions for Section A**

Answer **all** questions **for both** Areas of study in this section in the spaces provided.

Where an answer box has a unit printed in it, give your answer in that unit.

You should take the value of g to be 10 m s^{-2} .

Where answer boxes are provided write your final answer in the box.

Areas of study	Page
Electric power	4
Interactions of light and matter	13

This page is blank

Area of study 1 – Electric power

Figure 1 shows a coil of wire connected to a battery. The plane of the coil is perpendicular to the page.

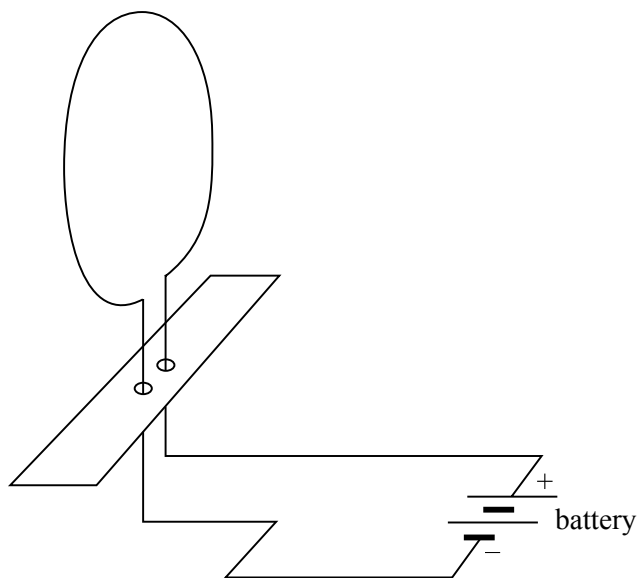

Figure 1

Question 1

Draw five magnetic field lines to show the magnetic field through the coil. You should include arrows to show direction.

2 marks

Use the following information to answer Questions 2–4.

Figure 2 shows a magnet with pole pieces that are each $40\text{ cm} \times 10\text{ cm}$.

The uniform magnetic field strength between the poles is $2.0 \times 10^{-3}\text{ T}$, and zero outside the poles.

A conducting wire, AB, carrying a current of 5.0 A , is placed between the poles as shown.

The force on the wire is upwards.

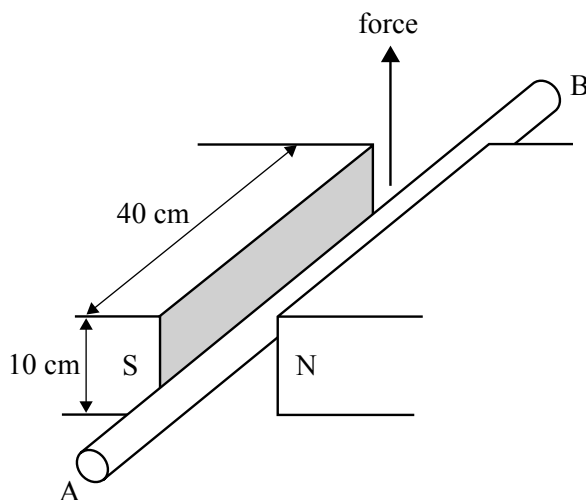

Figure 2

Question 2

In which direction, AB or BA, is the current flowing in the wire?

2 marks

Question 3

What is the magnitude of the force on the wire?

Show working.

 N

2 marks

Question 4

What is the total magnetic flux between the pole pieces?

Show working. Include a unit in your answer.

Magnitude	Unit
<input type="text"/>	<input type="text"/>

3 marks

Use the following information to answer Questions 5–7.

A group of students is studying DC generators and AC alternators.

They use a coil which rotates at a constant speed in the magnetic field as shown in Figure 3a.

The apparatus has slip rings **and** a commutator. Either the slip rings or the commutator can be connected to an oscilloscope to observe the output voltage.

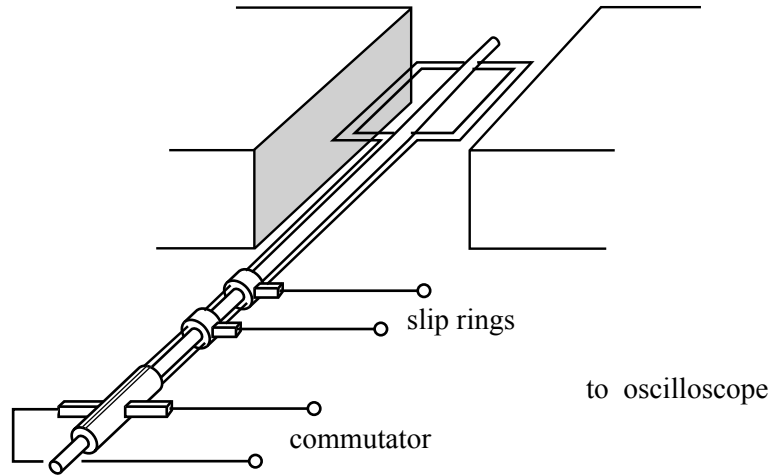

Figure 3a

Use the graphs in Figure 3b to answer Question 5–7.

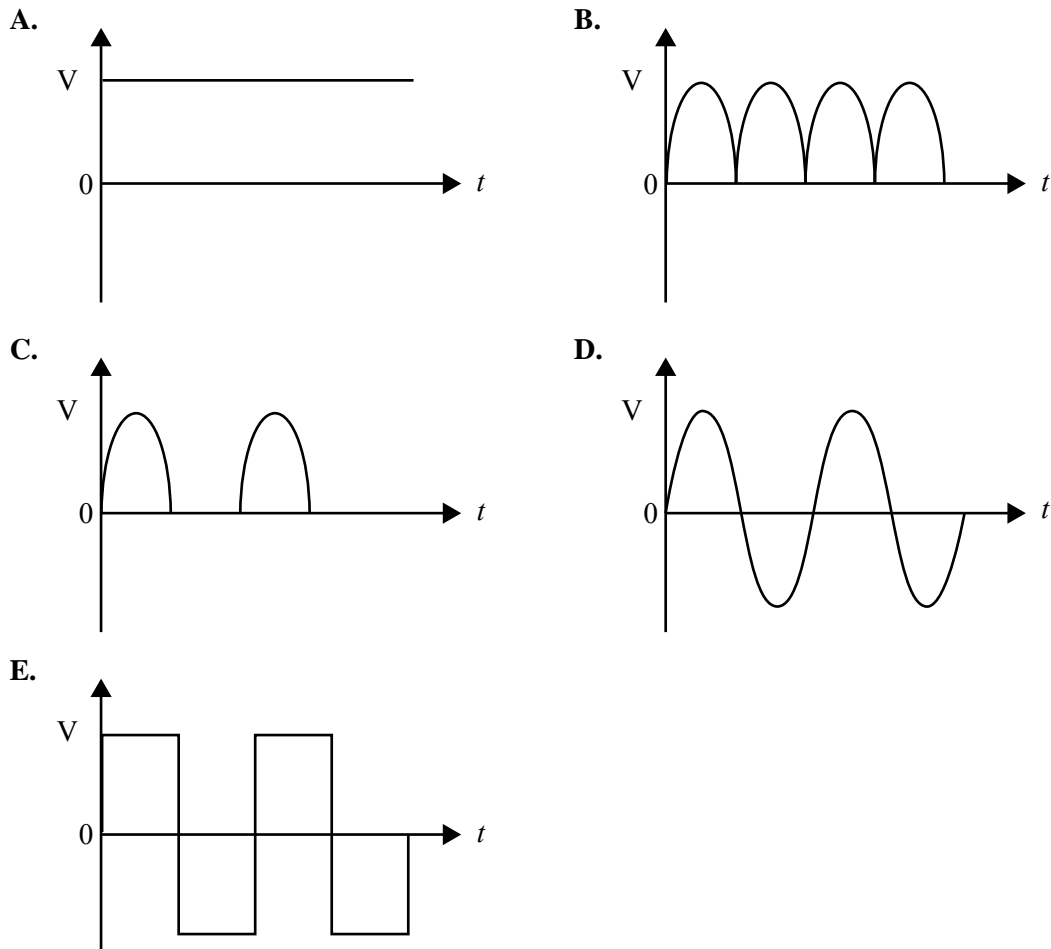

Figure 3b

Question 5

The oscilloscope is connected to the commutator. Which one of the graphs (A.–E.) best shows the shape of the output as observed on the oscilloscope?



2 marks

Question 6

The oscilloscope is next connected to the slip rings. Which one of the graphs (A.–E.) best shows the shape of the output as observed on the oscilloscope?



2 marks

Question 7

In diagram **D.** of Figure 3b, the peak-to-peak voltage is observed to be 8.0 V.

What will the RMS voltage be?

Show working.



2 marks

Use the following information to answer Questions 8–10.

A group of students is studying electromagnetic induction. The apparatus the students use is shown in Figure 4a.

The apparatus consists of a square magnet and a square loop that can move. The magnet, of sides 8.0 cm, has a uniform magnetic field strength of 4.0×10^{-3} T between the poles. The field can be considered zero outside the poles. The loop is square of side 2.0 cm. The loop moves through the magnet at a constant speed of 2.0 cm s^{-1} . Figure 4b shows the situation as seen from above.

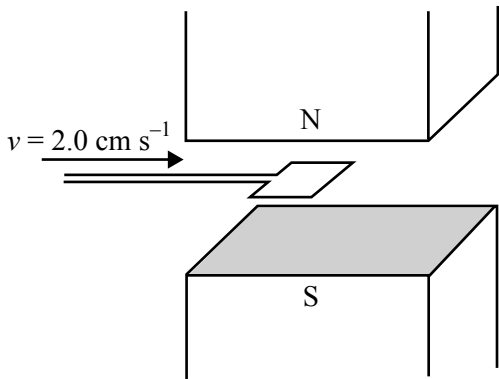

Figure 4a

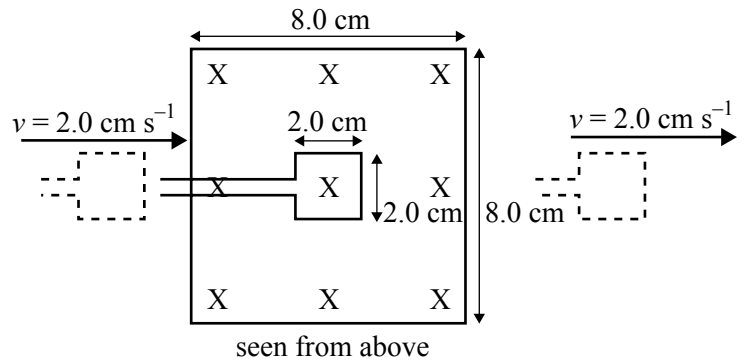

Figure 4b

X indicates field into page

Question 8

Which of the following diagrams (A.–F. in Figure 4c) best shows the shape of the output emf (voltage) induced in the loop as a function of time as the loop moves from outside the field at left to outside the field at right as shown in Figure 4b?

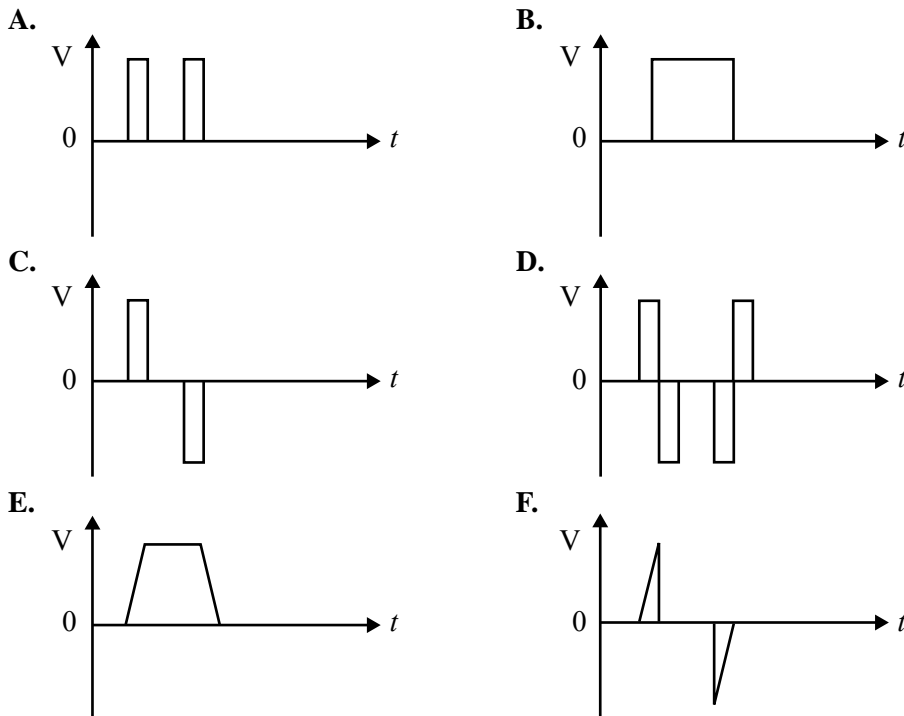

Figure 4c

2 marks

Use the following information to answer Questions 11–13.



Figure 5a

Bruce's garden has a pond with a fountain in it (as shown in Figure 5a). Bruce buys a floodlight to illuminate the fountain. The resistance of the floodlight filament is $3.0\ \Omega$ when operating.

Question 11

First Bruce tests the floodlight before he installs it. He tests it by applying $12\ \text{V}_{\text{RMS}}$ across the floodlight.

What is the power used in the floodlight when supplied with a voltage of $12\ \text{V}_{\text{RMS}}$?

Show working.

W

3 marks

Bruce now installs the floodlight.

The electricity supply for the floodlight is supplied from the house using two wires (as shown in Figure 5b). Each of the two wires that connect the supply has a resistance of $0.50\ \Omega$.

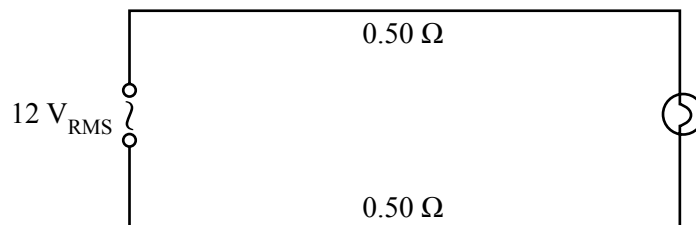

Figure 5b

Question 12

When operating, what is the voltage across the floodlight?

Show working.

V_{RMS}

3 marks

Bruce decides that the light is not bright enough and installs a second identical floodlight (as shown in the circuit below in Figure 5c).

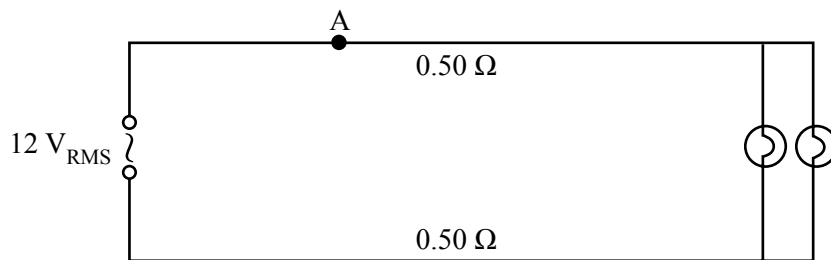

Figure 5c

Question 13

What is the current now flowing through the wire at point A?

Show working.

A

3 marks

Use the following information to answer Questions 14 and 15.

Jamie has a study lamp (shown in Figure 6) that uses a 40 W globe that operates at $18 \text{ V}_{\text{RMS}}$. The lamp plugs into the $240 \text{ V}_{\text{RMS}}$ supply, and a transformer (assumed to be ideal) in the base of the lamp provides the $18 \text{ V}_{\text{RMS}}$ for the globe.

The secondary coil of this small transformer has 30 turns.



Figure 6

Question 14

How many turns are on the primary coil?

Show working.

2 marks

Question 15

When operating, what is the current flowing in the **primary** coil?

Show working.

3 marks

Area of study 2 – Interactions of light and matter**Question 1**

Explain, in terms of electron behaviour, how light is produced in an incandescent (filament) light globe.

2 marks

Question 2

Describe how the spectrum of the light from an incandescent light globe differs from the spectrum of light from a mercury vapour lamp.

2 marks

Use the following information to answer Questions 3–5.

A group of students is studying Young’s double slit experiment using microwaves ($\lambda = 3.0 \text{ cm}$) instead of light.

A microwave detector is moved along the line PQ, and the maxima and minima in microwave intensity are recorded.

The experimental apparatus is shown in Figure 1.

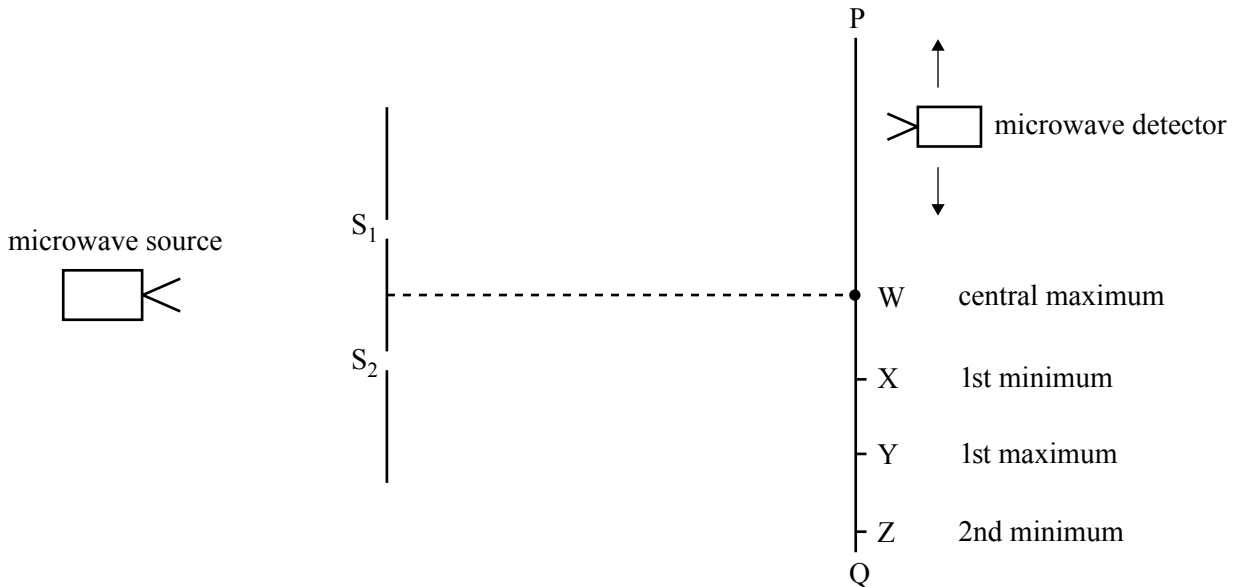

Figure 1

Question 3

What is the path difference $S_1Z - S_2Z$ in cm?

cm

2 marks

Question 4

Explain why there is a maximum in microwave intensity detected at point Y.

2 marks

Question 5

The students reduce the separation of the slits S_1 and S_2 .

Explain the effect of this change on the pattern of maxima and minima along the line PQ.

2 marks

Use the following information to answer Questions 6–8.

To study the photoelectric effect, students use the apparatus shown in Figure 2.

The apparatus consists of

- a light source
- a filter that allows only certain frequencies to pass
- a metal plate and collector electrode in a vacuum
- a variable DC source, voltmeter and ammeter.

The students shine light of different frequencies onto the metal plate. They measure the stopping (repelling) voltage (V_s) that just stops the emitted electrons reaching the collector.

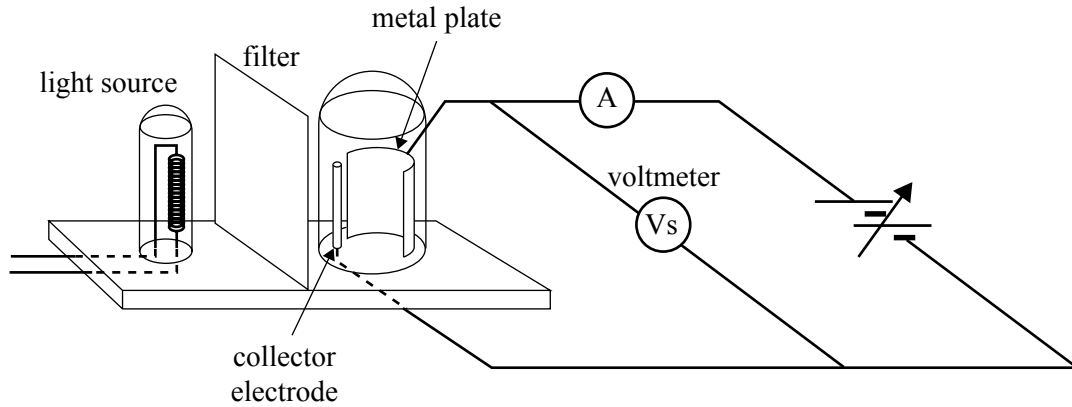

Figure 2

The data that the students gathered is shown in the table below.

Frequency (Hz)	Stopping voltage (Vs)
6.0×10^{14}	0.50
6.6×10^{14}	0.80
7.2×10^{14}	1.10
8.0×10^{14}	1.50

Question 6

Draw a suitable graph from the data above.

Label axes and provide units.

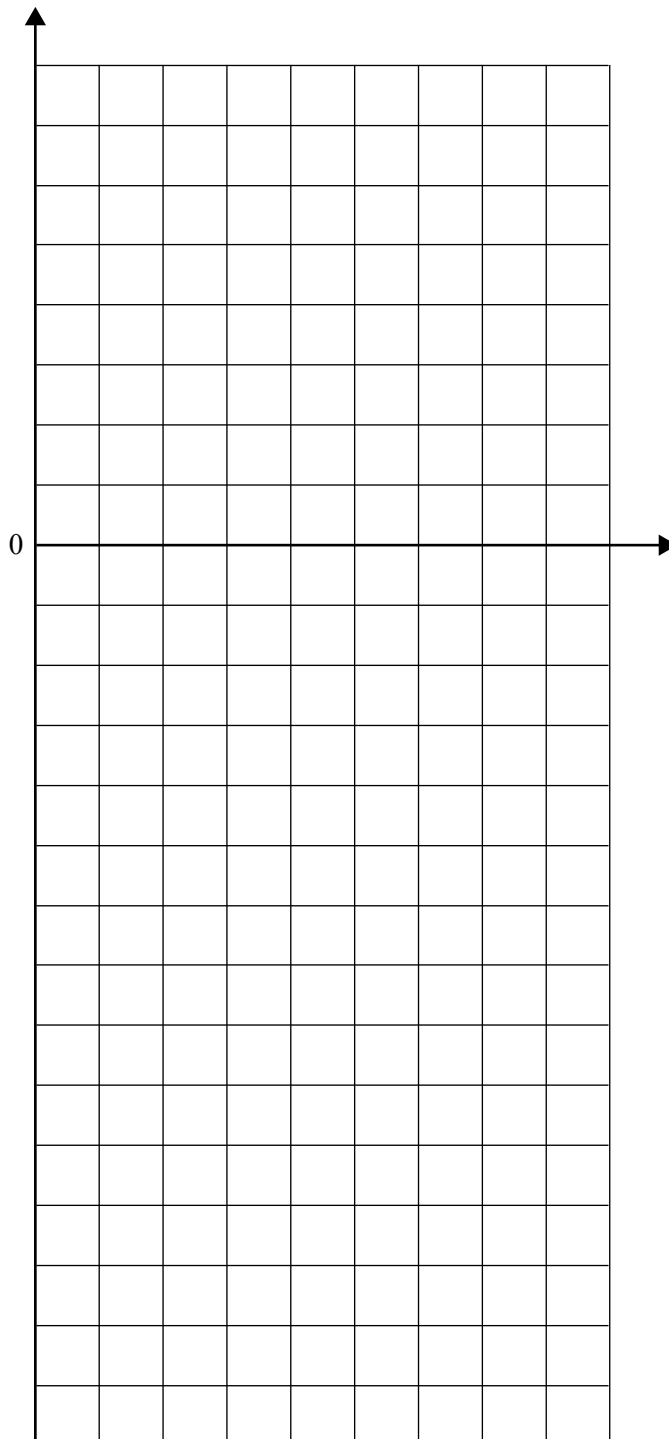

3 marks

SECTION A – Area of study 2 – continued

TURN OVER

Use the data from your graph in Question 6 to answer Questions 7 and 8.

Question 7

What value did the students determine from the graph for Planck's constant? Include a unit.

Magnitude	Unit
<input type="text"/>	<input type="text"/>

3 marks

Question 8

The work function is the minimum energy (eV) required to remove a photoelectron from a metal.

What value did the students determine from the graph for the work function of the metal of the plate?

<input type="text"/>	eV
----------------------	----

2 marks

Electrons of mass 9.1×10^{-31} kg emerge from an electron gun with a speed of 2.0×10^7 m s⁻¹.

Question 9

What is the de Broglie wavelength of the electrons in nm?

Show working.

nm

2 marks

Figure 3 shows the spectrum of light emitted from a hydrogen vapour lamp.

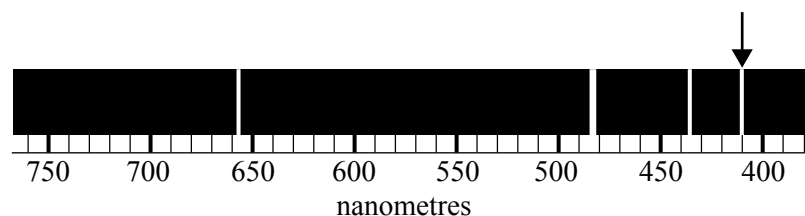

Figure 3

Question 10

The spectral line, indicated with the arrow on Figure 3, is in the visible region of the spectrum.

What is the energy, in eV, of a photon of this wavelength?

Show working.

eV

2 marks

Use the following information to answer Questions 11 and 12.

Figure 4 shows the quantised energy levels in the hydrogen atom, relative to the ground state.

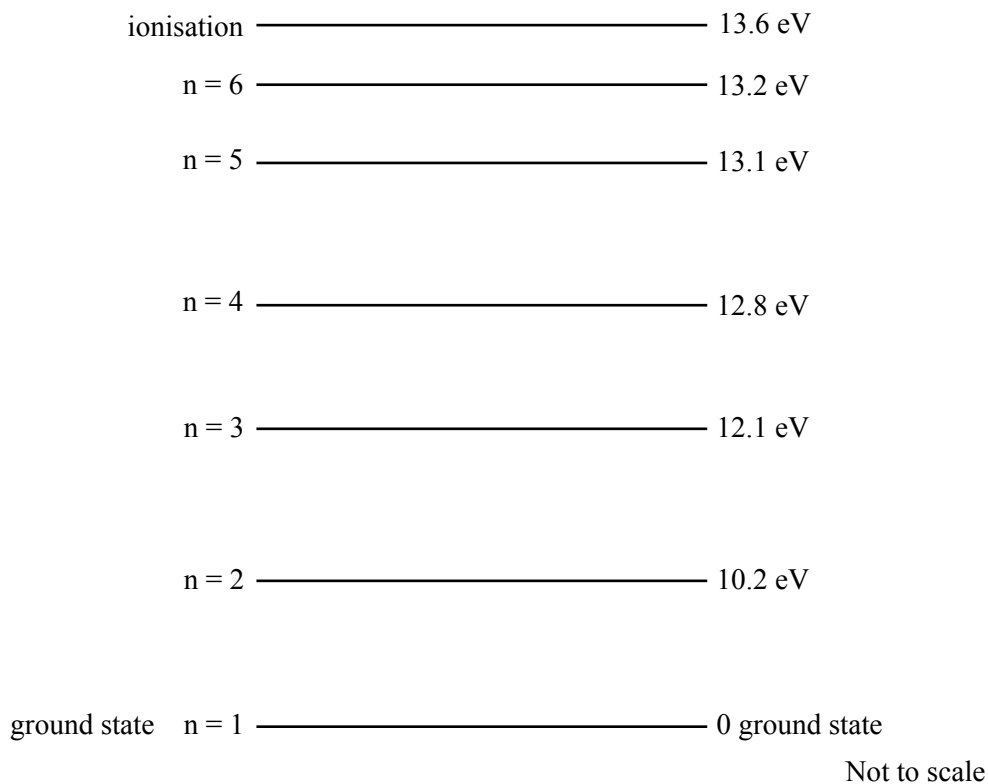

Figure 4

Question 11

A photon has an energy of 2.6 eV.

Indicate, by an arrow, on the energy level diagram in Figure 4, the transition corresponding to the emission of this photon.

2 marks

Question 12

What is the shortest wavelength photon that can be emitted when an atom decays from the $n = 4$ level?

nm

2 marks

END OF SECTION A

SECTION B – Detailed studies**Instructions for Section B**

Select **one** Detailed study.

Answer **all** questions from the Detailed study, in pencil, on the answer sheet provided for multiple-choice questions.

Write the name of your chosen Detailed study on the multiple-choice answer sheet **and** shade the matching box.

Choose the response that is **correct** for the question.

A correct answer scores 2, an incorrect answer scores 0.

Marks will **not** be deducted for incorrect answers.

No marks will be given if more than one answer is completed for any question.

You should take the value of g to be 10 m s^{-2} .

Detailed study	Page
Synchrotron and its applications	22
Photonics	27
Sound	33

Detailed study 1 – Synchrotron and its applications

The charge on the electron is $(-1.6 \times 10^{-19} \text{ C})$.

The mass of the electron is $9.1 \times 10^{-31} \text{ kg}$.

Question 1

In the electron gun of a synchrotron, electrons are accelerated by a voltage of 5000 V.

Which one of the following best gives the speed of the electrons?

- A. $1.8 \times 10^{15} \text{ m s}^{-1}$
 - B. $4.2 \times 10^7 \text{ m s}^{-1}$
 - C. $3.0 \times 10^8 \text{ m s}^{-1}$
 - D. $5.0 \times 10^3 \text{ m s}^{-1}$
-

Use the following information to answer Questions 2 and 3.

In a particular part of the synchrotron, electrons are maintained in a circular path by a magnetic field.

The electrons are moving at $4.00 \times 10^7 \text{ m s}^{-1}$, perpendicular to a magnetic field of strength $7.60 \times 10^{-4} \text{ T}$.

Question 2

Which one of the following best gives the force on each electron?

- A. $3.64 \times 10^{-23} \text{ N}$
- B. $4.86 \times 10^{-17} \text{ N}$
- C. $4.86 \times 10^{-15} \text{ N}$
- D. $1.26 \times 10^{-12} \text{ N}$

Question 3

Which one of the following best gives the radius of the electron's path?

- A. 0.30 m
 - B. 3.0 m
 - C. 4.6 m
 - D. 34 m
-

Question 4

Which one of the following sequences best gives the order in which electrons pass through the synchrotron?

- A. electron gun, booster ring, storage ring, linac
 - B. storage ring, linac, booster ring, beam line
 - C. electron gun, linac, booster ring, storage ring
 - D. linac, storage ring, booster ring, beam line
-

Question 5

Diffuse scattering of X-rays involves

- A. the broadening of the pattern due to thermal motion of atoms and electrons.
- B. diffraction as X-rays pass through the interatomic spacing.
- C. loss of energy by the X-rays to thermal motion of the electrons.
- D. gain of energy by X-rays from Compton collisions.

Question 6

Thomson scattering involves X-rays

- A. interacting with electrons with an increase in wavelength.
- B. interacting with electrons with a decrease in wavelength.
- C. interacting with electrons with no change in wavelength.
- D. absorbing energy from thermal motion and electrons.

Question 7

Compton scattering involves X-rays

- A. interacting with electrons with an increase in wavelength.
 - B. interacting with electrons with a decrease in wavelength.
 - C. interacting with electrons with no change in wavelength.
 - D. absorbing energy from thermal motion of electrons.
-

Use the following information to answer Questions 8–10.

One of the uses for synchrotron radiation is to produce monochromatic X-rays that will be used to measure crystal structure. One technique used in the following experiment is to use Bragg diffraction of X-rays from planes of atoms within the crystal ($n\lambda = 2d \sin \theta$). Figure 1a shows the experimental arrangement, and Figure 1b shows an enlarged view of the crystal planes that cause the diffraction. The crystal planes are distance d apart.

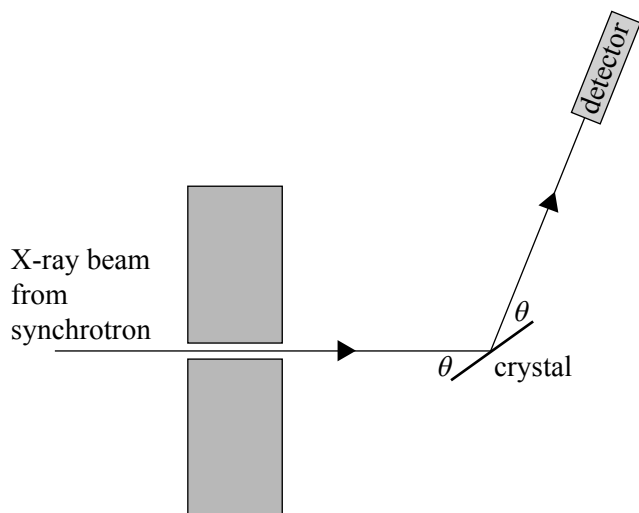

Figure 1a

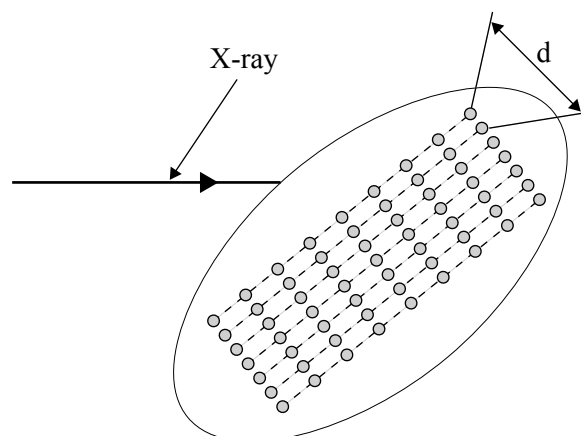

Figure 1b

A narrow beam of X-rays with a wavelength of 0.115 nm is incident on the crystal.

Question 8

Which one of the following values gives the best estimate of the energy of the X-rays?

- A. 156 keV
- B. 8.7 keV
- C. 6.4 keV
- D. 10.8 keV

In the experiment, **the angle θ of the crystal and the detector was increased** from zero while recording the number of X-rays detected. A sharp increase in the number of X-rays detected was observed at $\theta = 9.6^\circ$ as shown in Figure 2.

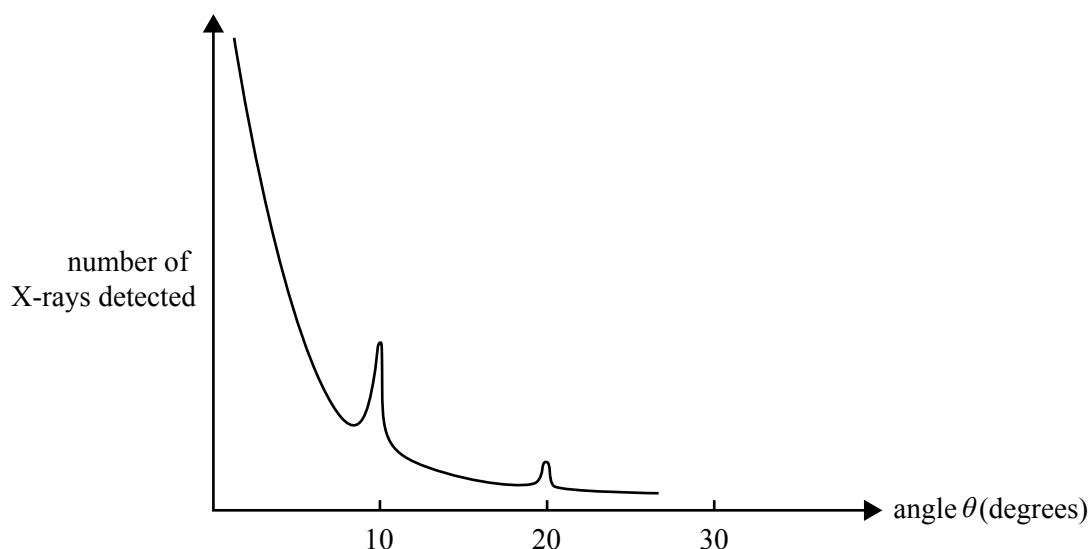

Figure 2

Question 9

Which one of the following values gives the best estimate of the spacing, **d**, between the crystal layers?

- A. 0.115 nm
- B. 0.172 nm
- C. 0.345 nm
- D. 0.689 nm

Question 10

As the angle θ was increased further, it was found that at $\theta = 20.2^\circ$ another increase in the number of X-rays was detected (shown in Figure 2).

From your understanding of Bragg's law, which one of the statements below best explains the presence of this second peak?

- A. The factor '2' in the formula means that there are peaks at angles differing by factor 2.
- B. At angle $\theta = 20.2^\circ$, diffraction is occurring from a different plane.
- C. Diffraction will always occur at angles that are approximate multiples of 9.6° .
- D. The X-ray beam is now entering at a different angle.

Question 11

Electrons enter the booster ring with a speed of approximately $0.99c$.

In the straight sections of the booster ring, the electrons are acted on by high voltage RF electric fields.

Which one of the following best describes the effect of these fields on the electrons?

- A. The kinetic energy and speed both increase substantially.
- B. The kinetic energy increases substantially but the speed increases only slightly.
- C. The kinetic energy increases slightly but the speed increases substantially.
- D. The kinetic energy and speed increase only slightly.

Use the following information to answer Questions 12 and 13.

Some physicists are discussing various means for measuring the interatomic spacing in crystals using Bragg diffraction.

They are discussing the relative merits of a synchrotron or an X-ray tube as the source of the required radiation.

They decide that a synchrotron is a better source of the required radiation.

Question 12

Which one of the following statements best gives the correct reasoning for this choice?

- A. An X-ray tube produces a much more intense and focused beam than a synchrotron beam.
- B. Wide spectrum radiation is suitable for interatomic spacing measurements by Bragg diffraction, provided the beam is sufficiently intense. Since a synchrotron produces a more intense beam than an X-ray tube, the synchrotron is more suitable.
- C. Monochromatic radiation is necessary for interatomic spacing measurements by Bragg diffraction. A synchrotron does produce a wide spectrum of X-rays in the beam line; however, this can be overcome by using a crystal tuning device in the beam line to obtain the required monochromatic radiation.
- D. For Bragg diffraction, it is more important that the beam be polarised rather than monochromatic. A synchrotron produces a beam that is more polarised than a laser; therefore the synchrotron is better.

Question 13

Which one of the following statements gives the best reason for the suitability of the synchrotron?

- A. The electrons in the beam line of a synchrotron, being of high energy, act as de Broglie waves, and so can be used for interatomic spacing measurements by Bragg diffraction.
- B. X-rays from the beam line of a synchrotron are more intense than from an X-ray tube, and hence give a clearer Bragg diffraction pattern.
- C. In a synchrotron, X-rays circulate in the circular storage ring. The most suitable wavelength for interatomic spacing measurements is diverted by magnetic fields into the beam line, hence providing a monochromatic source.
- D. Electrons circulating in the booster ring produce X-rays in the storage ring, which are then diverted into the beam line for use in interatomic spacing measurements.

Detailed study 2 – Photonics

Question 1

The spectra in the visible region produced by three light sources are shown in graphs 1, 2 and 3 in Figure 1.

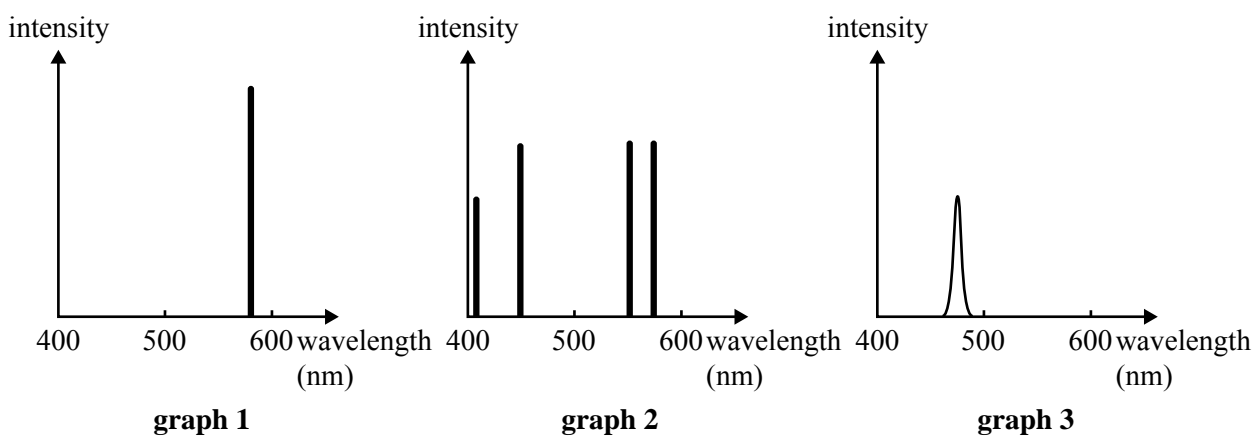

Figure 1

The light sources are a laser, a LED and a mercury vapour lamp (not in this order).

Which one of the following boxes correctly matches each graph with its source?

- | | LED | laser | mercury vapour lamp |
|----|---------|---------|---------------------|
| A. | graph 1 | graph 3 | graph 2 |
| B. | graph 2 | graph 1 | graph 3 |
| C. | graph 3 | graph 2 | graph 1 |
| D. | graph 3 | graph 1 | graph 2 |

The band gap of a LED is 1.80 eV.

Question 2

Which one of the following best gives the wavelength of light emitted by this LED?

- A. 110 nm
- B. 690 nm
- C. 6.90×10^{-7} nm
- D. 1.10×10^{-16} nm

Question 3

Comparing light from a laser and from a LED, which one of the following statements is true?

- A. Light from a LED is coherent but light from a laser is incoherent.
 - B. Light from both a LED and a laser is coherent.
 - C. Light from a laser has a narrow range of wavelengths (more monochromatic) than light from a LED.
 - D. Light from a LED is pulsed but light from a laser is continuous.
-

Question 4

Which one of the following statements best describes stimulated emission in a laser?

- A. Atoms are raised to a metastable state.
 - B. A population inversion is created.
 - C. Photons interact with atoms in a metastable state causing them to release their energy as photons.
 - D. Photons interact with the atoms in a metastable state to cause emission of electrons.
-

Figure 2 shows a stepped-index fibre cable. The core has a refractive index of $n = 1.48$ and the cladding $n = 1.41$. A ray of light is shown inside the fibre.

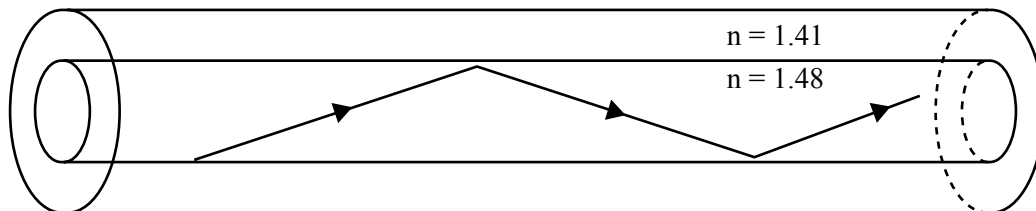

Figure 2

Question 5

Which one of the following best gives the critical angle for total internal reflection in the core of the fibre?

- A. 18°
 - B. 67°
 - C. 72°
 - D. 78°
-

Use the following information to answer Questions 6 and 7.

For a different optical fibre, of cladding 1.30 and core 1.50, the critical angle is 60° , as shown in Figure 3.

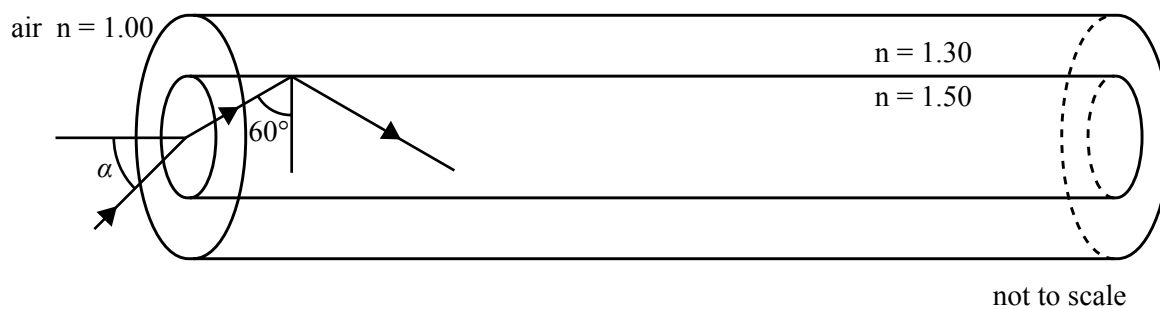

Figure 3

Question 6

Which one of the following best gives the acceptance angle α if the fibre is in air?

- A. 40.5°
- B. 48.5°
- C. 60.0°
- D. 86.9°

Question 7

The optical fibre is now placed in water ($n = 1.33$).

Which one of the following choices best identifies the effect of this on the critical angle and on the acceptance angle?

	Critical angle	Acceptance angle
A.	same	greater
B.	same	smaller
C.	greater	greater
D.	smaller	smaller

An optical fibre telecommunications link uses an infrared laser of wavelength $\lambda = 1300$ nm, with a power output into the fibre of 50 mW at the transmitting end. At the receiving end, a phototransistor is used; the phototransistor requires 20 mW input to operate.

The transmitter and receiver are linked by fibre-optic cable. The attenuation of the cable is shown in Figure 4.

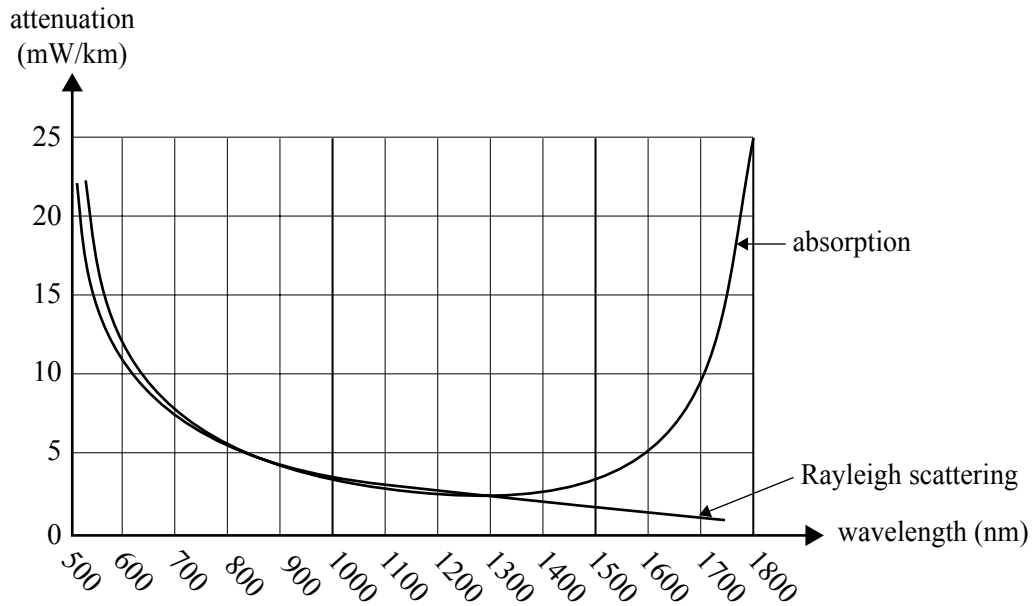

Figure 4

Question 8

Which one of the following distances gives the best estimate of maximum length of optical fibre that could be used for the system to operate correctly?

- A. 4 km
- B. 6 km
- C. 12 km
- D. 30 km

Question 9

A graded-index fibre has an advantage over step-index fibre because a graded-index fibre reduces the effect of

- A. material dispersion.
- B. Rayleigh scattering.
- C. modal dispersion.
- D. absorption.

Question 10

A laser source is superior to a LED source in a fibre-optic system because it causes less

- A. material dispersion.
- B. Rayleigh scattering.
- C. modal dispersion.
- D. absorption.

Question 11

Engineers wish to use fibre-optic imaging to examine corrosion on the inside of a pipe carrying water. The situation is shown in Figure 5. The mechanism for moving the device is not shown.

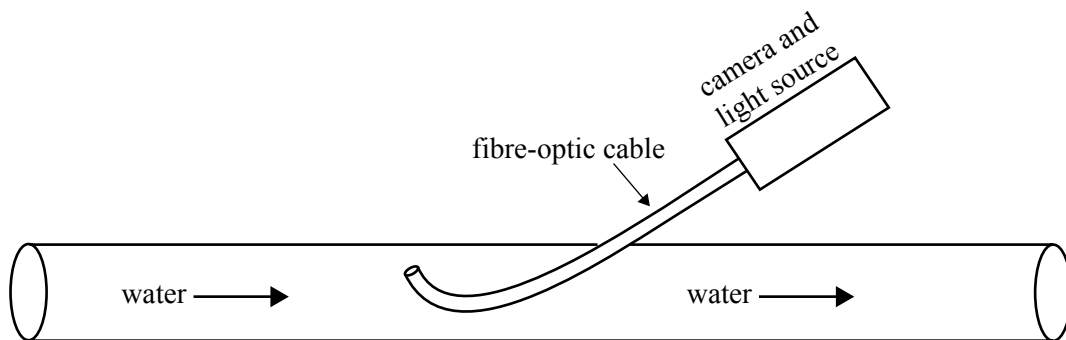
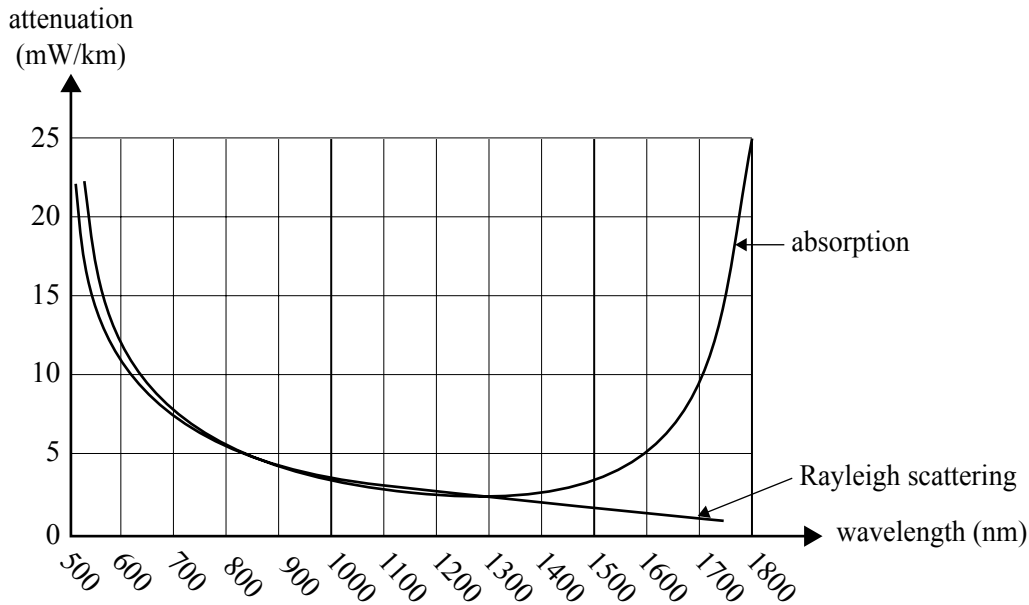

Figure 5

Which one of the following is the best estimate for the number of fibres in the optical cable?

- A. 1
- B. 5
- C. 1000
- D. 10 000 000

The information in this copy of Figure 4 may be of help in answering Questions 12 and 13.



Some physicists are discussing the design of a new system for long-distance transmission of data using light-fibre optics. They need to make a decision about two sets of options.

- whether to use red light (600 nm) or infrared (1300 nm)
- whether to use single mode or multi-mode fibre

Question 12

Which one of the following statements gives the best choice between red light and infrared, and the **correct reason** for this choice?

- Red light, since the total attenuation is less for red light.
- Red light, since absorption is less for red light.
- Infrared, since the total attenuation is less for infrared light.
- Infrared, since absorption is less for red light.

Question 13

Which one of the following statements gives the best choice between single mode and multi-mode fibre, and the **correct reason** for this choice?

- Single mode, since it has less modal dispersion.
- Single mode, since it has less material dispersion.
- Multi-mode, since it has less modal dispersion.
- Multi-mode, since it has less material dispersion.

Detailed study 3 – Sound

Question 1

Three types of microphone are

- electret-condenser
- crystal
- dynamic.

The physical properties on which the operation of these microphones depend are listed below (not in order).

- electromagnetic induction
- piezo-electric effect
- capacitance

Which one of the boxes correctly matches the microphone type to the relevant physical property?

	electret-condenser	crystal	dynamic
A.	piezo-electric effect	electromagnetic induction	capacitance
B.	capacitance	piezo-electric effect	electromagnetic induction
C.	capacitance	electromagnetic induction	piezo-electric effect
D.	electromagnetic induction	piezo-electric effect	capacitance

Use the following information to answer Questions 2 and 3.

A particle of dust is floating at rest 10 cm directly in front of a loudspeaker that is not operating. The loudspeaker then emits sound of frequency of 10 Hz and speed of 330 m s^{-1} .

Question 2

Which one of the following statements best describes the motion of the dust particle?

- A. It vibrates vertically up and down at 10 Hz remaining on average 10 cm in front of the loudspeaker.
- B. It vibrates horizontally backwards and forwards at 10 Hz remaining on average 10 cm in front of the loudspeaker.
- C. It travels away from the loudspeaker at 330 m s^{-1} while moving horizontally backwards and forwards at 10 Hz.
- D. It remains at rest.

The loudspeaker now emits a sound of frequency 220 Hz.

Question 3

Which one of the following best gives the wavelength of the sound from the loudspeaker?

- A. 0.67 m
 - B. 1.5 m
 - C. 220 m
 - D. $7.3 \times 10^4 \text{ m}$
-

Use the following information to answer Questions 4 and 5.

An isolated siren emits sound of 3000 Hz uniformly in all directions. At a point 20 m from the siren, the sound intensity is measured to be $1.0 \times 10^{-3} \text{ W m}^{-2}$.

Question 4

Which one of the following best gives the sound intensity level (in dB) at this point?

- A. $1.0 \times 10^{-3} \text{ dB}$
- B. 9.0 dB
- C. 90 dB
- D. 100 dB

The sound intensity is measured at a distance of 60 m from the siren.

Question 5

Which one of the following best gives the sound intensity (in W m^{-2}) at 60 m?

- A. $3.3 \times 10^{-3} \text{ W m}^{-2}$
 - B. $1.1 \times 10^{-4} \text{ W m}^{-2}$
 - C. $3.0 \times 10^{-2} \text{ W m}^{-2}$
 - D. $9.0 \times 10^{-3} \text{ W m}^{-2}$
-

Use the following information to answer Questions 6 and 7.

The graph in Figure 1 shows the relationship between sound intensity level (dB), frequency (Hz) and loudness (phon).

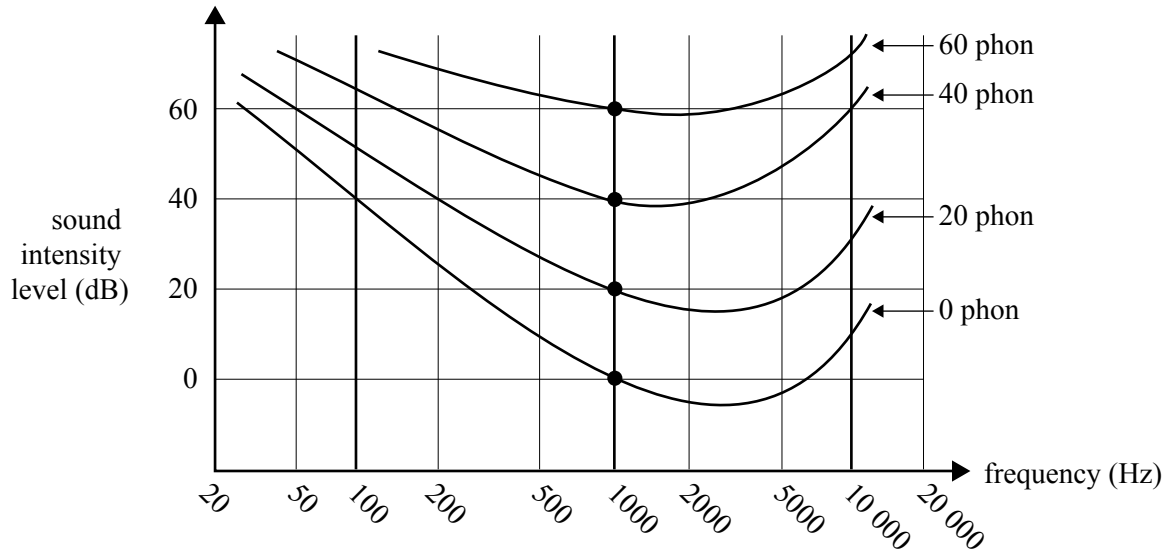

Figure 1

The sound intensity level (dB) of a note of 10 000 Hz is measured by a sound meter to be 60 dB.

Question 6

Which one of the values below best gives the loudness in phon at this point?

- A. 20 phon
- B. 40 phon
- C. 60 phon
- D. 80 phon

Question 7

The loudness scale (phon) specifically takes account of which one of the following factors?

- A. Intensity of sound, as perceived by human hearing, is inversely proportional to distance from the source.
- B. The perception of sound by human hearing is logarithmic, rather than linear, compared to sound intensity.
- C. The perception of the intensity of sound by human hearing varies with frequency.
- D. Human hearing has a very limited range of frequencies that it can hear.

Use the following information to answer Questions 8–11.

Roger, an instrument maker, is constructing and testing pipes for a pipe organ.

The pipes can be considered to be uniform tubes open at one end and closed at the other.

He measures the speed of sound in air at the time of the test to be 333 m s^{-1} .

Question 8

One pipe is designed to produce the note middle C (256 Hz).

Which one of the following best gives the wavelength corresponding to middle C?

- A. 0.38 m
- B. 0.77 m
- C. 1.3 m
- D. 2.6 m

Roger tests the pipe by placing a loudspeaker attached to a very precise audio signal generator at the open end of the pipe, and gradually increases the frequency.

He finds that in addition to the resonance at 256 Hz, there is a higher resonance (the second harmonic).

Question 9

At which one of the following frequencies will this second harmonic be observed?

- A. 128 Hz
- B. 512 Hz
- C. 768 Hz
- D. 1024 Hz

Question 10

Which one of the following statements best describes how Roger was able to identify this second harmonic?

- A. At the frequency of this second harmonic a standing wave is set up in the tube. This absorbs sound energy, hence the volume heard by Roger decreases.
- B. At the frequency of this second harmonic the first harmonic is also heard, so when Roger hears this as well, he knows the signal generator is at a harmonic.
- C. At the frequency of this second harmonic a standing wave is set up in the tube. This causes the volume heard by Roger to increase.
- D. At the frequency of this second harmonic the fidelity (quality) of the note changes, and Roger is able to identify this.

Question 11

Roger is later designing a different pipe to give a wavelength of 0.325 m.

Which one of the following lengths should Roger make the pipe?

- A. 0.081 m
 - B. 0.325 m
 - C. 0.65 m
 - D. 1.30 m
-

Use the following information to answer Questions 12 and 13.

Two physicists are discussing the design of a new theatre for use by a school choir. The design requirement is for good acoustic properties; in particular, for even distribution of sound over the whole frequency range throughout the theatre.

A plan of the theatre to be used is shown in Figure 2.

The stage opening is approximately 3 m wide.

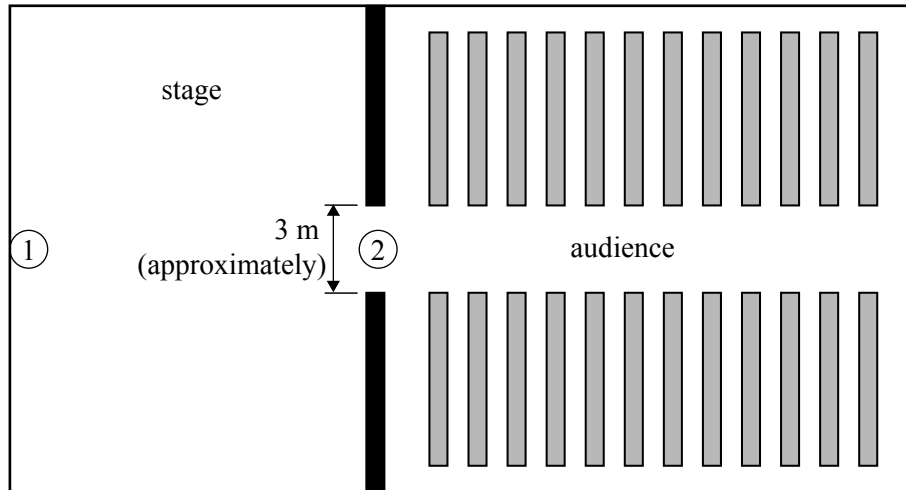

Figure 2

The positioning of the loudspeaker or speakers is an important decision.

The physicists are discussing two locations for the main speaker.

- position 1 – at the rear of the stage

or

- position 2 – above the stage opening

Question 12

Which one of the following statements is the best statement about the placement of the speaker and the **correct reason** for the placement?

- If the speakers are at position 1 (rear of stage), no sound at all will be heard at the outer ends of the front row, due to diffraction.
- If the speakers are at position 1 (rear of stage), the sound heard in the outer ends of the front rows will be distorted due to diffraction – different frequencies would be heard differently.
- If the speakers are at position 1 (rear of stage), the actors and performers can hear, and the dimensions and wavelengths are such that diffraction will not be a problem.
- If the speakers are at position 2 (above the stage opening), the speakers are close to the audience. The frequencies will be heard at slightly different times, and the sound will be distorted, as different frequencies travel at different speeds.

One of the physicists wants to line the walls of the audience area of the theatre with heavy sound-absorbing curtains.

Question 13

Which one of the following states why this is a good idea?

- A. The curtains will reduce the effect of diffraction through the stage opening, hence producing better quality sound.
- B. Without the curtains, different frequencies will reflect differently from the walls, causing distortion due to diffraction effects.
- C. Without the curtains, different frequencies will reflect differently from the walls, causing distortion due to interference effects.
- D. Without the curtains, there would be multiple paths from the speaker to each member of the audience, thus causing distortion and sound loss due to interference effects in some parts of the theatre.

PHYSICS

Written examination 2

DATA SHEET

Directions to students

Detach this data sheet before commencing the examination.

This data sheet is provided for your reference.

1	photoelectric effect	$E_{k\max} = hf - W$
2	photon energy	$E = hf$
3	photon momentum	$p = \frac{h}{\lambda}$
4	de Broglie wavelength	$\lambda = \frac{h}{p}$
5	resistors in series	$R_T = R_1 + R_2$
6	resistors in parallel	$\frac{1}{R_T} = \frac{1}{R_1} + \frac{1}{R_2}$
7	magnetic force	$F = I l B$
8	electromagnetic induction	emf : $\varepsilon = -N \frac{\Delta\Phi}{\Delta t}$ flux: $\Phi = BA$
9	transformer action	$\frac{V_1}{V_2} = \frac{N_1}{N_2}$
10	AC voltage and current	$V_{\text{RMS}} = \frac{1}{\sqrt{2}} V_{\text{peak}}$ $I_{\text{RMS}} = \frac{1}{\sqrt{2}} I_{\text{peak}}$
11	voltage; power	$V = RI$ $P = VI$
12	transmission losses	$V_{\text{drop}} = I_{\text{line}} R_{\text{line}}$ $P_{\text{loss}} = I_{\text{line}}^2 R_{\text{line}}$
13	mass of the electron	$m_e = 9.11 \times 10^{-31} \text{ kg}$
14	charge on the electron	$e = -1.60 \times 10^{-19} \text{ C}$
15	Planck's constant	$h = 6.63 \times 10^{-34} \text{ J s}$ $h = 4.14 \times 10^{-15} \text{ eV s}$
16	speed of light	$c = 3.0 \times 10^8 \text{ m s}^{-1}$

Detailed study 3.1 – Synchrotron and applications

17	energy transformations for electrons in an electron gun (<100 keV)	$\frac{1}{2} m v^2 = eV$
18	radius of electron beam	$r = m v / eB$
19	force on an electron	$F = evB$
20	Bragg's law	$n\lambda = 2d \sin \theta$
21	electric field between charged plates	$E = \frac{V}{d}$

Detailed study 3.2 – Photonics

22	band gap energy	$E = \frac{hc}{\lambda}$
23	Snell's law	$n_1 \sin i = n_2 \sin r$

Detailed study 3.3 – Sound

24	speed, frequency and wavelength	$v = f\lambda$
25	intensity and levels	<p>sound intensity level (in dB) = $10 \log_{10} \left(\frac{I}{I_0} \right)$ where $I_0 = 1.0 \times 10^{-12} \text{ W m}^{-2}$</p>

Prefixes/Units

p = pico = 10^{-12}

n = nano = 10^{-9}

μ = micro = 10^{-6}

m = milli = 10^{-3}

k = kilo = 10^3

M = mega = 10^6

G = giga = 10^9

t = tonne = 10^3 kg

END OF DATA SHEET