



Victorian Certificate of Education 2012

SUPERVISOR TO ATTACH PROCESSING LABEL HERE

STUDENT NUMBER

Letter

Figures

Words

SYSTEMS ENGINEERING

Written examination

Monday 19 November 2012

Reading time: 9.00 am to 9.15 am (15 minutes)

Writing time: 9.15 am to 10.45 am (1 hour 30 minutes)

QUESTION AND ANSWER BOOK

Structure of book

<i>Section</i>	<i>Number of questions</i>	<i>Number of questions to be answered</i>	<i>Number of marks</i>
A	20	20	20
B	24	24	65
			Total 85

- Students are permitted to bring into the examination room: pens, pencils, highlighters, erasers, sharpeners, rulers and one scientific calculator.
- Students are NOT permitted to bring into the examination room: blank sheets of paper and/or white out liquid/tape.

Materials supplied

- Question and answer book of 21 pages including formulas on page 21.
- Answer sheet for multiple-choice questions.

Instructions

- Write your **student number** in the space provided above on this page.
- Check that your **name** and **student number** as printed on your answer sheet for multiple-choice questions are correct, **and** sign your name in the space provided to verify this.
- All calculations must show appropriate formulas and working.
- All written responses must be in English.

At the end of the examination

- Place the answer sheet for multiple-choice questions inside the front cover of this book.

Students are NOT permitted to bring mobile phones and/or any other unauthorised electronic devices into the examination room.

SECTION A – Multiple-choice questions**Instructions for Section A**

Answer **all** questions in pencil on the answer sheet provided for multiple-choice questions.

Choose the response that is **correct** for the question.

A correct answer scores 1, an incorrect answer scores 0.

Marks will **not** be deducted for incorrect answers.

No marks will be given if more than one answer is completed for any question.

A formula sheet is provided on page 21.

Unless indicated diagrams are not to scale.

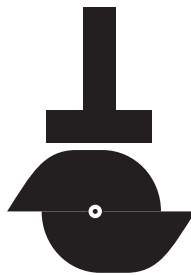
Question 1

When the camshaft shown above is rotated one complete turn, the mechanism

- A. lifts and falls once.
- B. lifts and falls four times.
- C. converts rotary motion into reciprocating motion.
- D. works only in an anticlockwise rotation of the cam.

Question 2

The thread pitch of a bolt is 1 mm. The bolt is tightened 180° after first contact with the parts to be fastened. How much stretch has been applied to the bolt shank?

- A. no stretch
- B. 0.25 mm
- C. 0.5 mm
- D. 1 mm

Question 3

A mains-operated piece of electrical equipment in a school has been tagged as faulty.

Who is allowed to remove the tag and return the mains-operated piece of electrical equipment to service?

- A. a cleaner
- B. a teacher
- C. an approved student
- D. a licensed electrician

Question 4

A pedestal drill is being used in a workshop. Sparks and smoke are emitted from the pedestal drill's switchbox.

What immediate action would you take?

- A. Isolate the pedestal drill.
- B. Use another pedestal drill.
- C. Hose the pedestal drill with water.
- D. Use personal protection equipment.

Use the following information to answer Questions 5–7.

A diaphragm liquids pump is operated by a lever from a rotating cam.

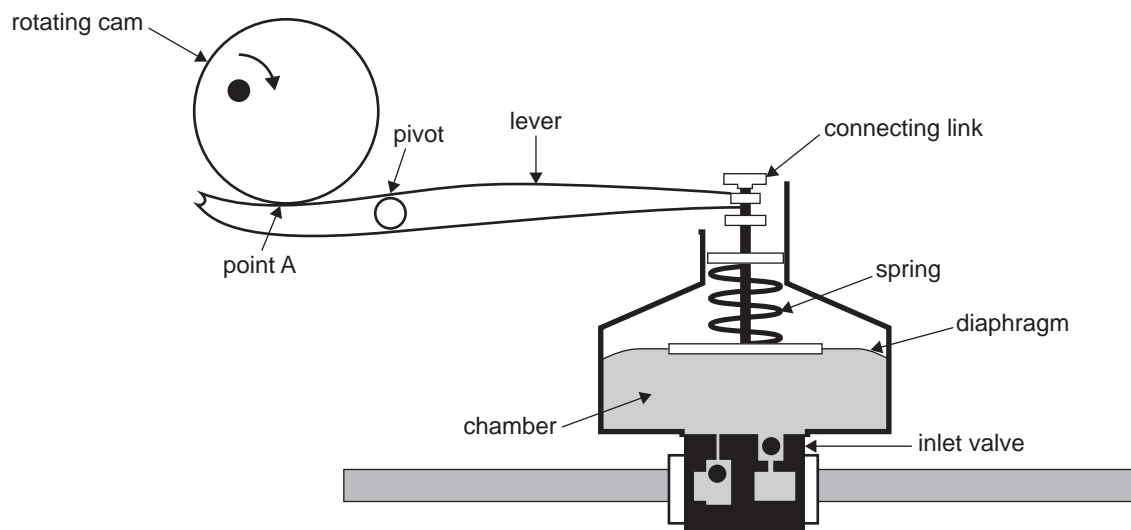
**Question 5**

The force exerted on the connecting link compared with the force applied to the lever by the rotating cam as it rotates will be

- A. less at all times.
- B. more at all times.
- C. equal at all times.
- D. less or more depending on the position of the rotating cam.

Question 6

Point A on the lever indicates the position of the

- A. rotation of the cam.
- B. balance.
- C. effort.
- D. load.

Question 7

When the rotating cam is actuating the lever, the chamber has

- A. low pressure.
- B. high pressure.
- C. zero pressure.
- D. atmospheric pressure.

Question 8

A bolt is to be tightened with a spanner to a torque of 100 Nm.

If the spanner is 40 cm long, then the force applied to the end of the spanner is

- A. 2.5 N
- B. 40.0 N
- C. 250.0 N
- D. 400.0 N

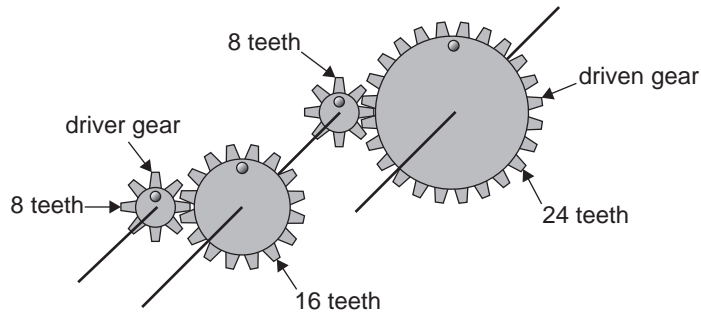
Question 9

The gear ratio of the compound gears shown above is

- A. 5:1
- B. 6:1
- C. 1:6
- D. 8:40

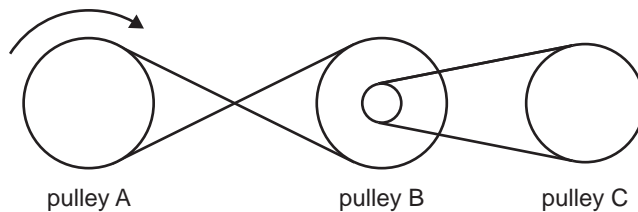
Question 10

If pulley A rotates clockwise, pulley C will rotate

- A. clockwise and faster.
- B. clockwise and slower.
- C. anticlockwise and faster.
- D. anticlockwise and slower.

Question 11

When a nut on a bolt is tightened, what type of force is applied to the shank on the bolt?

- A. linear
- B. torsion
- C. tension
- D. compression

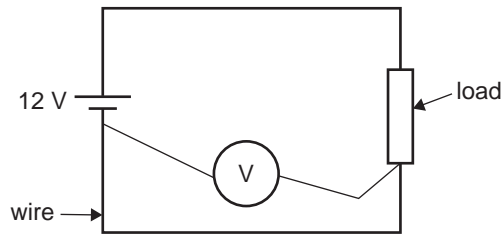
Question 12

The voltmeter shown above has a reading of 1 V from the battery to the load.

One way of reducing the reading of 1 V when the circuit is operating is to

- A. increase the diameter of the wire.
- B. decrease the diameter of the wire.
- C. put a resistor in parallel to the load.
- D. put a capacitor in series in the circuit.

Question 13

The electric current in a printed circuit board's copper track is caused by the flow of

- A. ions.
- B. protons.
- C. neutrons.
- D. electrons.

Question 14

A 12 V solar panel is used to charge a 12 V battery. The battery provides power for an electric pump that uses 4 A for 4 hours a day. A solar panel is used to charge the battery and it provides 2 A for 6 hours a day.

In the long run

- A. the battery will go flat.
- B. the battery will stay charged.
- C. the electric pump will not work in the dark.
- D. the electric pump will work for only 2 hours each day.

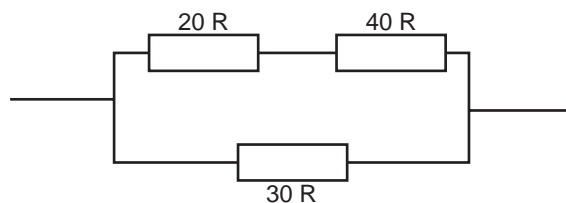
Question 15

The total resistance of the circuit shown above is

- A. 20 R
- B. 30 R
- C. 40 R
- D. 90 R

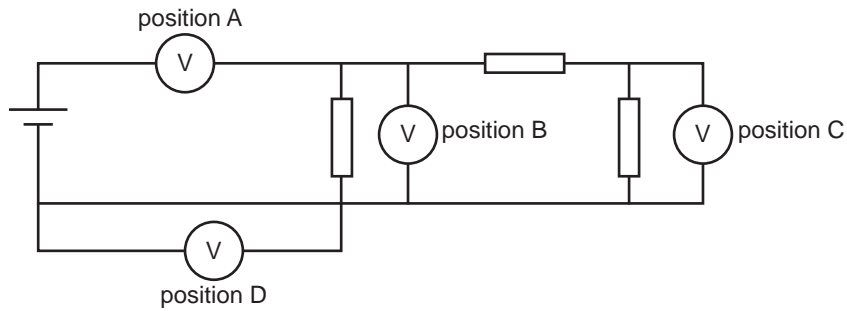
Question 16

A voltmeter is used to measure the voltage of the battery shown above.

In which position should the voltmeter be placed?

- A. position A
- B. position B
- C. position C
- D. position D

Question 17

Which of the following does not detect light?

- A. a phototransistor
- B. an infrared receiver
- C. a light-emitting diode
- D. a light-dependent resistor

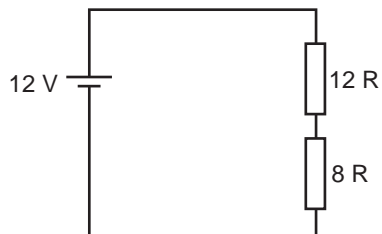
Question 18

The total current in the circuit shown above is

- A. 0.6 A
- B. 1.0 A
- C. 1.5 A
- D. 2.5 A

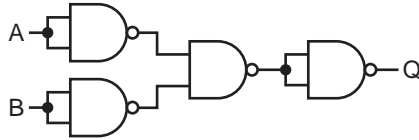
Question 19

Which of the following truth tables represents the circuit shown above?

A.

A	B	Q
0	0	0
0	1	0
1	0	0
1	1	1

B.

A	B	Q
0	0	1
0	1	0
1	0	0
1	1	0

C.

A	B	Q
0	0	0
0	1	1
1	0	1
1	1	0

D.

A	B	Q
0	0	0
0	1	1
1	0	1
1	1	1

Question 20

Which of the following is an input device for an electronic system?

- A.** a buzzer
- B.** a relay switch
- C.** a seven-segment display
- D.** a light-dependent resistor

SECTION B – Short answer questions

Instructions for Section B

Answer **all** questions in the spaces provided.
 A formula sheet is provided on page 21.
 Unless indicated the diagrams are not to scale.

Before children had motorised cars to drive around, they had pedal cars. To operate a pedal car, the child pushes the pedals back and forth. These pedals then cause the axle to turn.

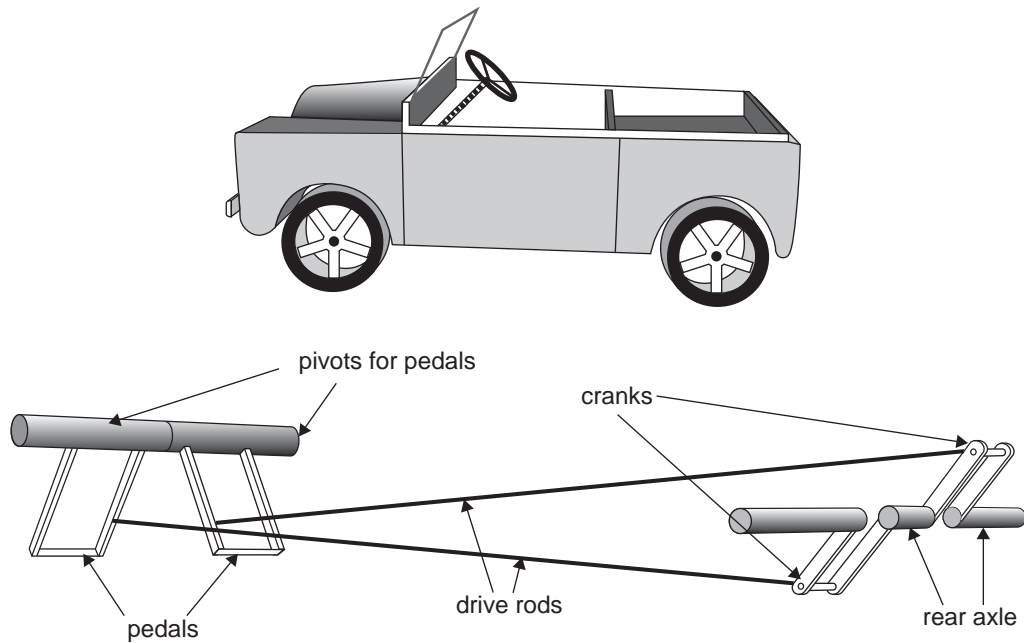

Figure 1

Question 1

State the type of motion of

a. the pedals _____

1 mark

b. the cranks. _____

1 mark

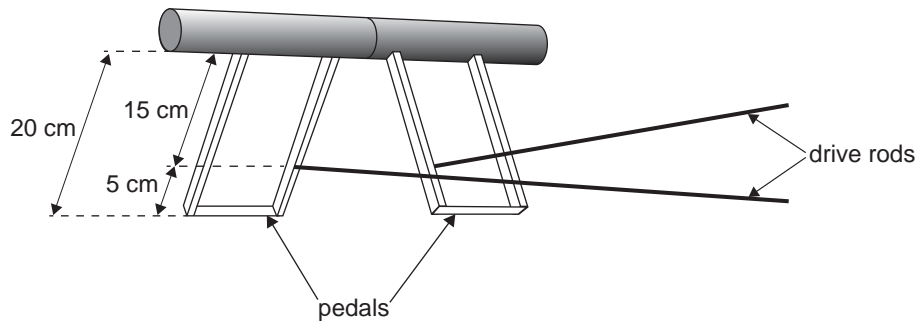

Figure 2

Question 2

If the maximum force applied to the base of the pedals is 120 N, what is the maximum effective force on the drive rods? Show working.

2 marks

Question 3

What class of lever is the pedal in Figure 2?

1 mark

Once the pedal car is moving, a child can keep pushing each pedal at a rate of 2 pushes per second.

Question 4

a. What is the revolution per minute (rpm) of the rear wheels?

1 mark

b. If each wheel has a diameter of 25 cm, how fast will the pedal car travel in metres per second? Show working.

2 marks

c. A speedometer on the pedal car shows a reading of 4 m/s. Describe a test to determine the accuracy of the speedometer using a measuring tape and stopwatch. State the expected measurements.

2 marks

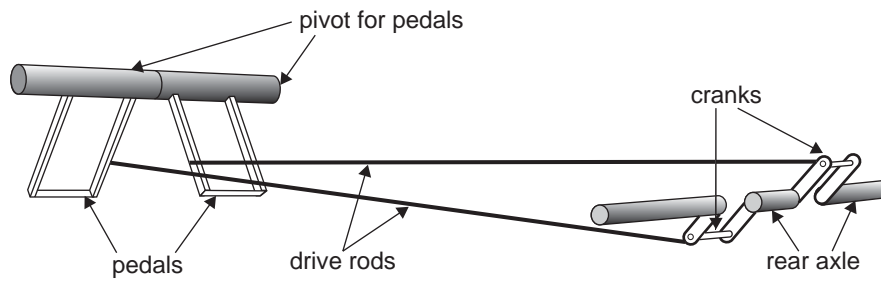

Figure 3

Question 5

The cranks of the pedal car are shortened, as shown above.

State the effect of this on the operation of the pedal car when the pedals are pushed at a rate of 2 pushes per second.

1 mark

Figure 4 shows an incomplete steering mechanism for the pedal car.

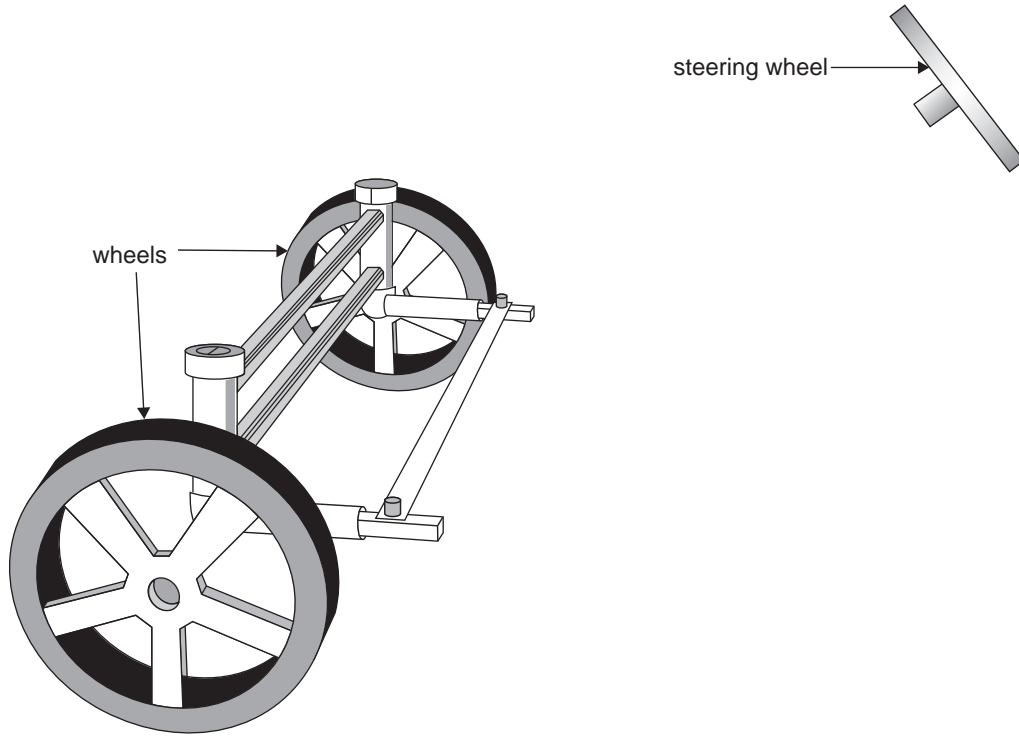

Figure 4

Question 6

a. On the diagram above, design a safe steering mechanism that will allow the pedal car to be steered. Label any components you use.

3 marks

b. Describe how your steering mechanism works.

2 marks

Question 7

a. Identify two processes that you would use in the construction of the steering mechanism that you designed in Question 6.

1. _____
2. _____

2 marks

b. State a different safety precaution for each of the processes that you have selected.

1. _____
2. _____

2 marks

The builder of the pedal car wants to replace the pedal system with a constant-speed electric motor and drive system. A metal disc with a radius of 50 mm and a moveable rubber roller are used for the drive system, as shown in Figures 5a and 5b.

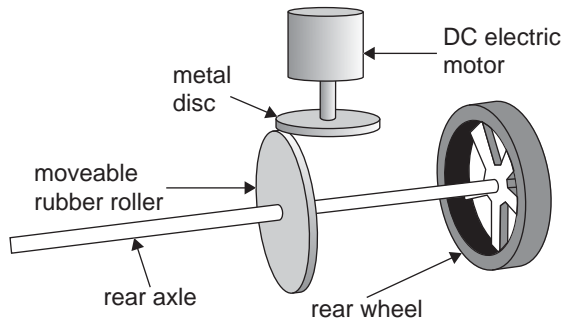

Figure 5a

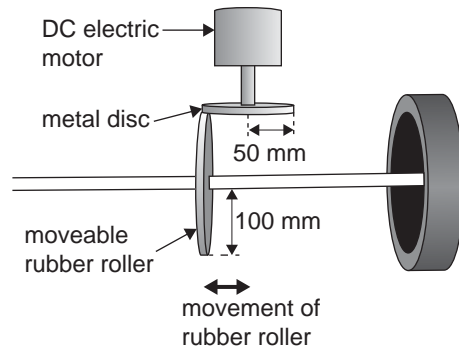

Figure 5b

Question 8

a. The metal disc rotates at 1000 rpm.

Calculate the rpm of the rubber roller, as shown in Figure 5b. Show working.

2 marks

b. What happens to the rpm of the rubber roller if it is moved to the right of its position in Figure 5b?

1 mark

c. A child decides to oil the drive system.

What effect will this have on the operation of the car?

1 mark

d. How could the builder modify this simple drive system to achieve reverse drive? Suggest both a mechanical and an electrical method.

mechanical _____

electrical _____

2 marks

A hydraulic disc braking system is to be used on the car. The diameter of the disc brake cylinder is 60 mm and the diameter of the master cylinder is 20 mm. The braking system is shown in Figure 6.

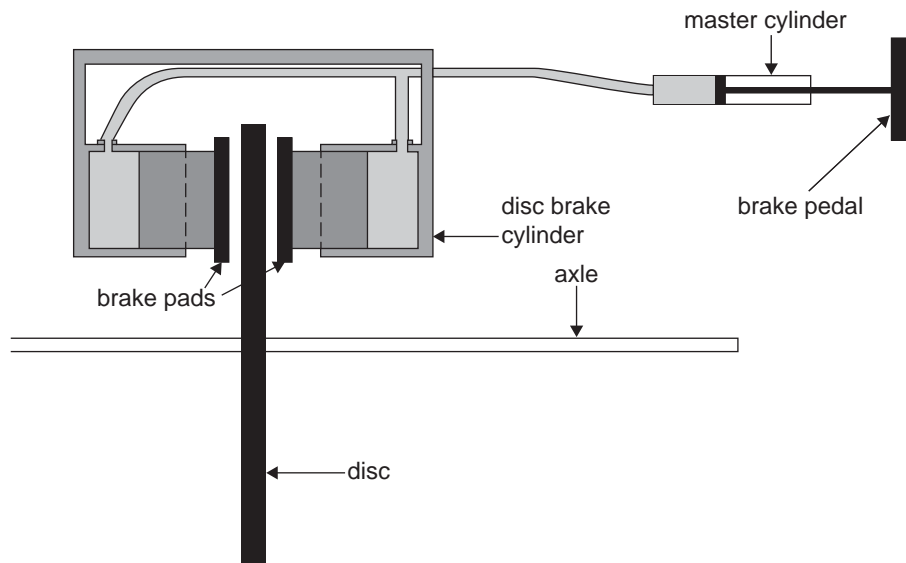

Figure 6

Question 9

- a. If a force of 120 N is applied to the brake pedal, calculate the pressure in the system. Include any working and the final units.

2 marks

- b. Calculate the force applied to each of the brake pads. Give your answer in newtons (N).

2 marks

The builder of the car wants to explore the possibility of powering the car with a new technology. He does not want to use fossil fuels. At this stage, the builder does not want to use solar energy.

Question 10

a. Name two renewable sources of energy (other than solar energy).

1. _____

2. _____

2 marks

b. Explain how one of the renewable sources of energy that you named in **part a.** can be used to power the car.

1 mark

c. Give one reason why your chosen energy source has an environmental advantage when compared to fossil fuels.

1 mark

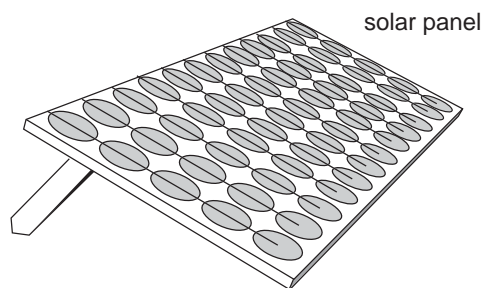

Figure 7

Finally, the builder decides to power the car with an electric motor and a battery that is charged by solar panels. He decides to use a 2 m^2 panel, which generates a peak output of 120 W .

Question 11

If the solar cells are 20% efficient, calculate the minimum amount of solar energy that needs to fall on the panels to generate 120 W . Show working.

2 marks

The process of charging the battery is 90% efficient. The electric motor used is 80% efficient.

Question 12

Calculate the combined efficiency of the battery and the electric motor.

1 mark

Question 13

The electric motor is operated. It is noticed that, after running for a while, the motor gets hot. Identify two causes of the motor heating up.

1. _____

2. _____

2 marks

Two front lights and two rear lights are fitted to the car. Each light is rated 12 V and 24 W. A 12 V car battery is used as the power source. Only one switch is used. This switch turns all four lights on together at full brightness and also turns them all off. A fuse is used to protect the circuit.

Question 14

Calculate the electric current that flows through one light globe. Show working and include units.

2 marks

Question 15

Complete the circuit diagram (Figure 8 below) using appropriate symbols to show how the electrical components should be wired up. (Include four light globes, a fuse, wiring, the battery and a switch. The battery and switch symbols are provided.)

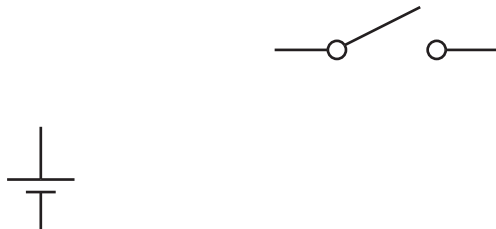

Figure 8

3 marks

Question 16

The car battery needs recharging after use.

State one safety precaution when recharging a car battery.

1 mark

In the circuit (Figure 8) a 1A-rated switch was used and was found to overheat. A possible solution is to fit an SPDT 10A relay and a new 1A switch.

Question 17

a. What do the letters SPDT stand for?

1 mark

b. Complete the circuit diagram (Figure 9 below) to show how the relay can be used to switch the lights on or off, given that the switch controls the relay. (Assume that the light globes and fuse are in the box, as shown.)

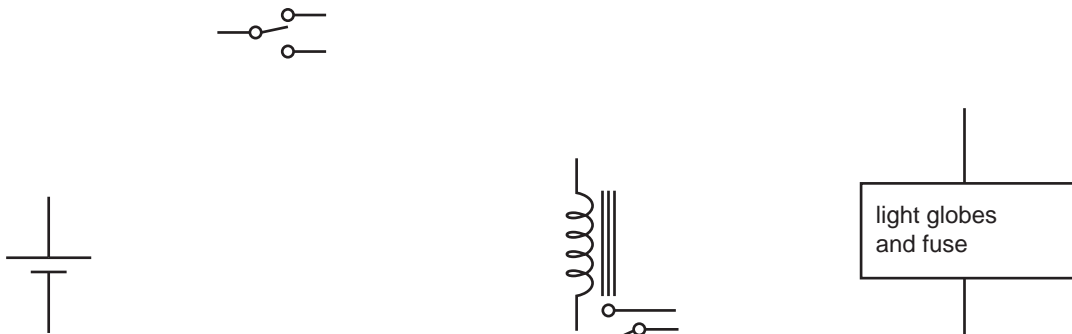

Figure 9

3 marks

Flashing brake lights are fitted to the car using the electronic circuit shown in Figure 10 below.

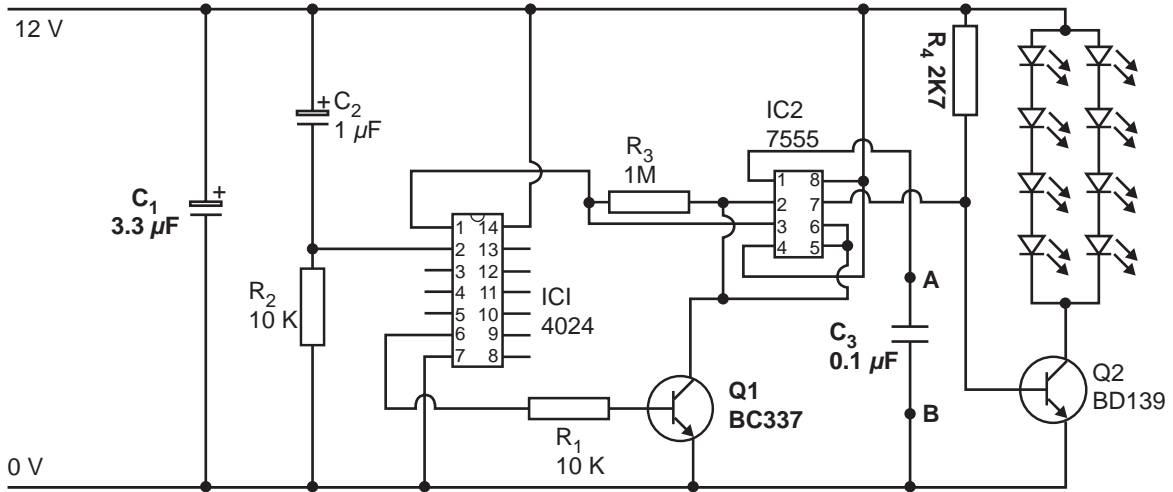

Figure 10

Question 18

- a. Resistor R_4 is a four-colour band resistor and has a value of 2K7 with a tolerance of 5%. List, in order, the four colours of resistor R_4 .

1 mark

- b. Capacitor C_1 has a value of $3.3 \mu\text{F}$. What do the letters μF stand for?

1 mark

- c. Name component Q1 and name the leg connected to the 10 K resistor.

component Q1 _____

name of leg _____

2 marks

The flash rate of the brake light can be changed by increasing the capacitance between points A and B in the circuit.

Question 19

State how this can be done without removing capacitor C_3 .

1 mark

Question 20

Resistor R_4 on the printed circuit board is found to be faulty and needs to be replaced.

List, in order, the steps needed to fully complete this task. Include the tools and safety equipment required.

3 marks

An oscilloscope was placed across the output LEDs. Figure 11 shows the output that was displayed on the screen.

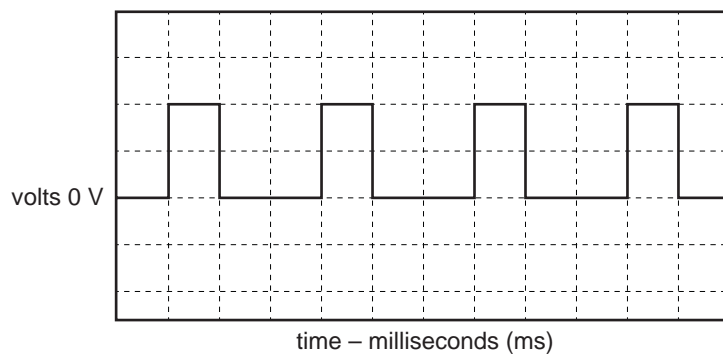
**Figure 11****Question 21**

Given that the vertical setting is 5 V per division and the horizontal setting is 50 ms per division, calculate

- a. the maximum voltage output

1 mark

- b. the frequency of the output correct to two decimal places.

1 mark

Question 22

Name two mechanical and two electrical subsystems within the child’s motorised car.

mechanical

1. _____

2. _____

electrical

1. _____

2. _____

2 marks

Question 23

Select one of the subsystems named in Question 22. Give the input and output of this subsystem.

selected subsystem _____



2 marks

Question 24

Modern motor cars have many open- and closed-loop systems.

a. Name a closed-loop system in a modern motor car.

1 mark

b. Explain why your answer to **part a.** is a closed-loop system.

1 mark

Formula sheet

Gear ratio final = gear ratio 1 \times gear ratio 2

$$\text{Efficiency} = \frac{\text{output energy}}{\text{input energy}} \times 100\%$$

Voltage = current \times resistance

$$\text{Resistors in parallel: } R_t = \frac{R_1 \times R_2}{R_1 + R_2}$$

Colour codes

Colour	Value
black	0
brown	1
red	2
orange	3
yellow	4
green	5
blue	6
violet	7
grey	8
white	9
gold	5%
silver	10%

Resistors in series: $R_t = R_1 + R_2$

Power = voltage \times current

Area of circle = πr^2 ($\pi = 3.14$)

Circumference of circle = $2\pi r$

Force = pressure \times area

$$\frac{\text{gear A rpm}}{\text{gear B rpm}} = \frac{\text{number of teeth gear B}}{\text{number of teeth gear A}}$$

$$\frac{\text{pulley A rpm}}{\text{pulley B rpm}} = \frac{\text{radius of pulley B}}{\text{radius of pulley A}}$$

$$\text{Speed} = \frac{\text{distance}}{\text{time}}$$

$$\text{Gear ratio} = \frac{\text{number of teeth on driven gear}}{\text{number of teeth on driver gear}}$$

$$\text{Mechanical advantage} = \frac{\text{load}}{\text{effort}}$$

Torque = force \times distance

$$\text{Frequency} = \frac{1}{\text{period}}$$

$$\text{Efficiency}_{\text{Total}} = \text{Efficiency}_1 \times \text{Efficiency}_2$$