

STUDENT NUMBER           Letter

## SYSTEMS ENGINEERING

### Written examination

Monday 20 November 2017

Reading time: 9.00 am to 9.15 am (15 minutes)

Writing time: 9.15 am to 10.45 am (1 hour 30 minutes)

### QUESTION AND ANSWER BOOK

#### Structure of book

<i>Section</i>	<i>Number of questions</i>	<i>Number of questions to be answered</i>	<i>Number of marks</i>
A	20	20	20
B	15	15	80
			Total 100

- Students are permitted to bring into the examination room: pens, pencils, highlighters, erasers, sharpeners, rulers and one scientific calculator.
- Students are NOT permitted to bring into the examination room: blank sheets of paper and/or correction fluid/tape.

#### Materials supplied

- Question and answer book of 27 pages
- Detachable insert of miscellaneous formulas in the centrefold
- Answer sheet for multiple-choice questions

#### Instructions

- Write your **student number** in the space provided above on this page.
- Check that your **name** and **student number** as printed on your answer sheet for multiple-choice questions are correct, **and** sign your name in the space provided to verify this.
- Unless otherwise indicated, the diagrams in this book are **not** drawn to scale.
- All written responses must be in English.

#### At the end of the examination

- Place the answer sheet for multiple-choice questions inside the front cover of this book.
- You may keep the detached insert.

**Students are NOT permitted to bring mobile phones and/or any other unauthorised electronic devices into the examination room.**

## SECTION A – Multiple-choice questions

### Instructions for Section A

Answer **all** questions in pencil on the answer sheet provided for multiple-choice questions.

Choose the response that is **correct** or that **best answers** the question.

A correct answer scores 1; an incorrect answer scores 0.

Marks will **not** be deducted for incorrect answers.

No marks will be given if more than one answer is completed for any question.

Unless otherwise indicated, the diagrams in this book are **not** drawn to scale.

#### Question 1

Eye protection is required when performing tasks such as using a cold chisel, a bench grinder or a drill.

Under what circumstances is eye protection **not** required when using a cold chisel, a bench grinder or a drill?

- A. when the user can turn their head away and not look
- B. when wearing sunglasses with an acrylic lens
- C. when wearing prescription glasses
- D. when wearing a clear face shield

#### Question 2

When using a bench grinder, it is best practice to

- A. keep the wheel cool by spraying it with water.
- B. make sure someone else is watching from close by.
- C. move the work across the wheel and not use the wheel's side face.
- D. stand in front of the wheel and watch it gain speed to ensure it is running true.

#### Question 3

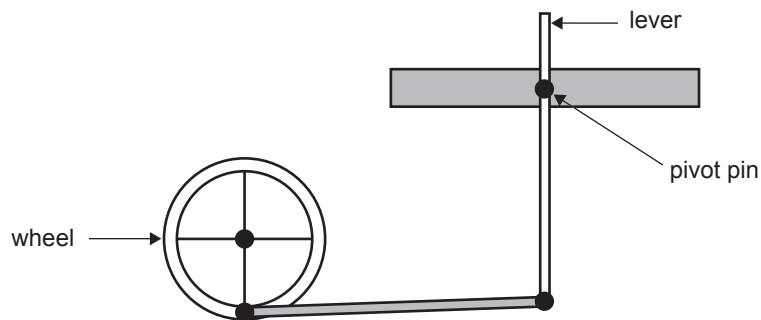

Which type of motion would best describe the lever's action in the diagram above?

- A. oscillating
- B. elliptical
- C. rotary
- D. linear

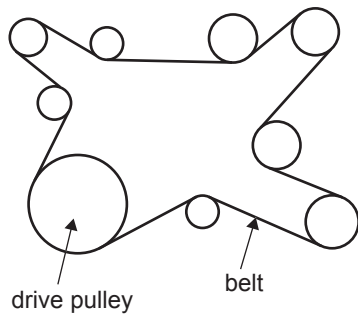
**Question 4**

In the pulley system shown above, the drive pulley turns in a clockwise direction.  
How many other pulleys will move in the same direction?

- A. 3
- B. 4
- C. 5
- D. 8

**Question 5**

Which type of gear can be used to convert rotary motion into linear motion?

- A. spur
- B. bevel
- C. worm
- D. rack and pinion

**Question 6**

Newton's third law states that

- A. for every action there is an equal but opposite reaction.
- B. the force on an object is given by the mass times acceleration.
- C. a body stays at rest or in constant motion unless acted on by another force.
- D. the energy of an object is given by the mass times the velocity squared, then divided by two.

Use the following information to answer Questions 7 and 8.

A model steam train has a mass of 400 kg and has a force of 200 N applied to it. The train starts from rest, has a constant acceleration and covers 40 m in 12.6 s.

**Question 7**

The work done by the steam engine in the train is

- A. 80 kJ
- B. 8 kJ
- C. 5 J
- D. 2 J

**Question 8**

The power output of the steam engine in the train is

- A. 10 W
- B. 50 W
- C. 504 W
- D. 635 W

**Question 9**

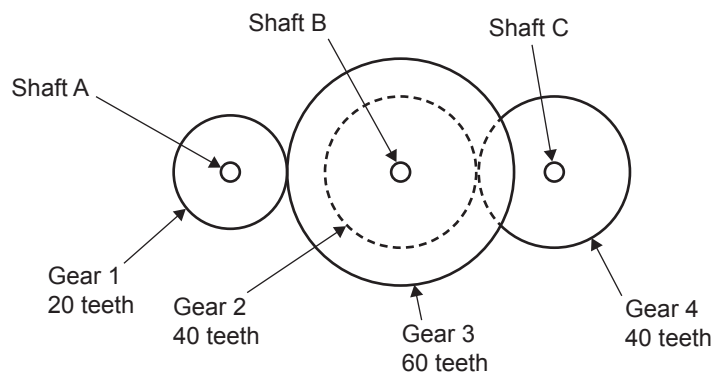

In the gear system shown above, Gear 1 is the driver gear, Gear 4 is the driven gear, and Gear 2 and Gear 3 are joined together.

What is the gear ratio of the system?

- A. 1:3
- B. 1:2
- C. 2:1
- D. 3:1

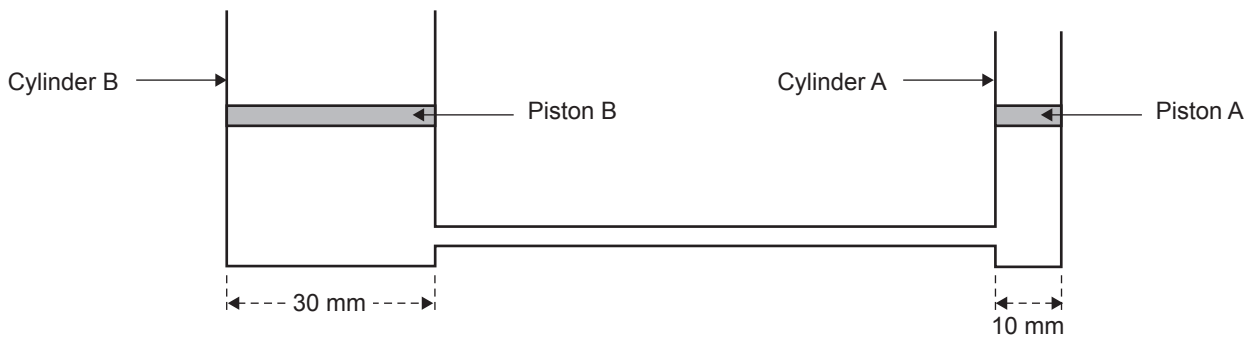
**Question 10**

In the diagram shown above, if Piston A has a force of 360 N acting down on it, what is the force of Piston B?

- A. 3240 N
- B. 1080 N
- C. 360 N
- D. 120 N

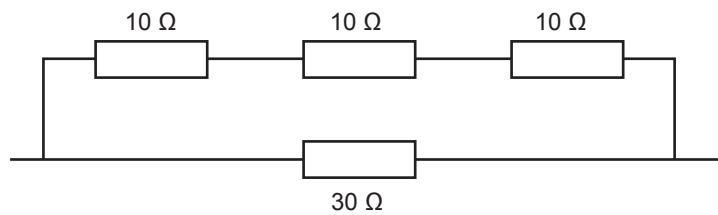
**Question 11**

What is the total resistance of the arrangement of resistors shown above?

- A.  $60\ \Omega$
- B.  $33.3\ \Omega$
- C.  $15\ \Omega$
- D.  $10\ \Omega$

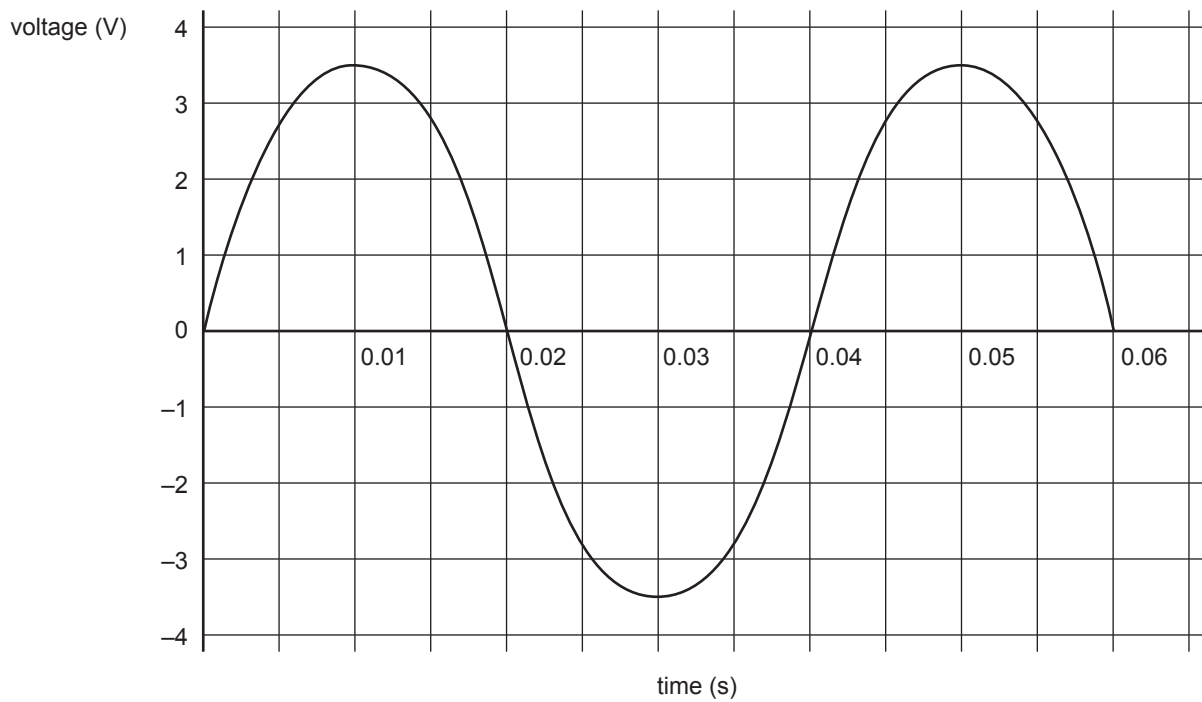
**Question 12**

The peak voltage of the signal shown above is

- A. 3.5 V
- B.  $3.5 \times 0.7071$  V
- C.  $\frac{7}{\sqrt{2}}$  V
- D. 7 V

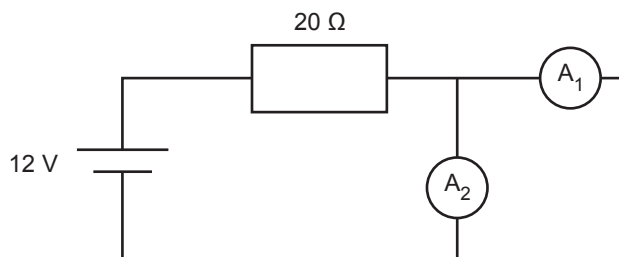
**Question 13**

The current through ammeter  $A_1$  in the circuit shown above is

- A. 120 A
- B. 240 A
- C. 300 mA
- D. 600 mA

**Question 14**

The AND gate shown above has 1 Hz and 8 Hz inputs.  
What is the most likely output signal of the AND gate?

- A.
- B.
- C.
- D.

**Question 15**

The number 16 180 written in engineering notation and correct to two significant figures is

- A.  $1.6 \times 10^4$   
 B.  $1.62 \times 10^4$   
 C.  $16 \times 10^3$   
 D.  $16.2 \times 10^3$

**Question 16**

The primary purpose of a Zener diode is to

- A. emit light.  
 B. act as a voltage regulator.  
 C. let current pass in one direction.  
 D. produce a full-wave rectified signal.

**Question 17**

Energy is collected from the sun using solar panels. The energy is stored in a battery and used later to boil water in a kettle.

Given that the solar panels are 20% efficient, the batteries are 90% efficient and the kettle is 50% efficient, what is the total efficiency?

- A. 9%  
 B. 20%  
 C. 53.3%  
 D. 90%

**Question 18**

A hydrogen cell, or fuel cell, works by

- A. burning hydrogen and oxygen together to produce water and electricity.
- B. combining hydrogen and oxygen in an electrolyte to produce water and electricity.
- C. converting water to hydrogen and oxygen, and then burning the oxygen to produce electricity.
- D. converting water to hydrogen and oxygen, and then burning the hydrogen to produce electricity.

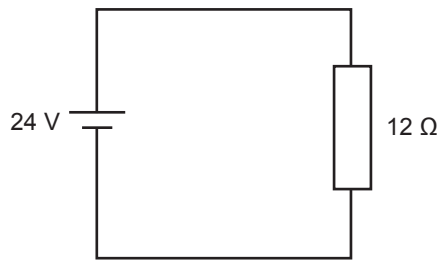
**Question 19**

The power dissipated through the circuit shown above is

- A. 2 W
- B. 48 W
- C. 50 W
- D. 288 W

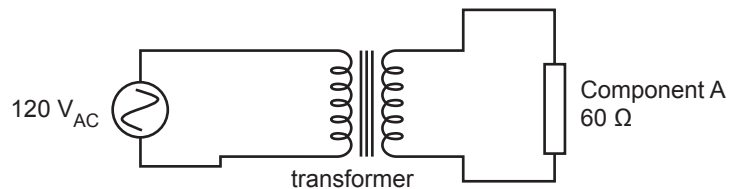
**Question 20**

There are 500 primary windings and 50 secondary windings in the transformer shown above. What is the current through Component A?

- A. 20 mA
- B. 50 mA
- C. 200 mA
- D. 500 mA



**SECTION B****Instructions for Section B**

Answer **all** questions in the spaces provided.

All calculations must show appropriate formulas and working.

Unless otherwise indicated, the diagrams in this book are **not** drawn to scale.

Lucy has built a quarter-scale model steam locomotive that she wants to operate on a small track, as shown in Figure 1.

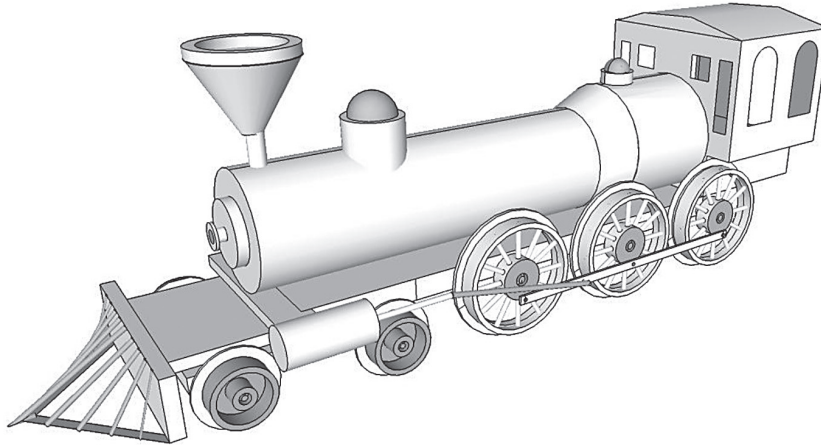

**Figure 1**

**Question 1** (1 mark)

What is the length of the scale model, given that the original train was 8.0 m long?

---

m
---

**Question 2** (3 marks)

In the table below, state the main form of energy found in each item.

Item	Form of energy
wood	
steam	
moving locomotive	

**Question 3** (6 marks)

Lucy is about to design the small track. As part of the layout, she needs to use a set of points to allow the model steam locomotive to change direction. A tie bar is connected to switch point blades so that the train can move in a straight line or turn right. With the points in the dotted position, the locomotive goes straight ahead. With the points in the solid position, the locomotive goes right. This set-up is shown in Figure 2.

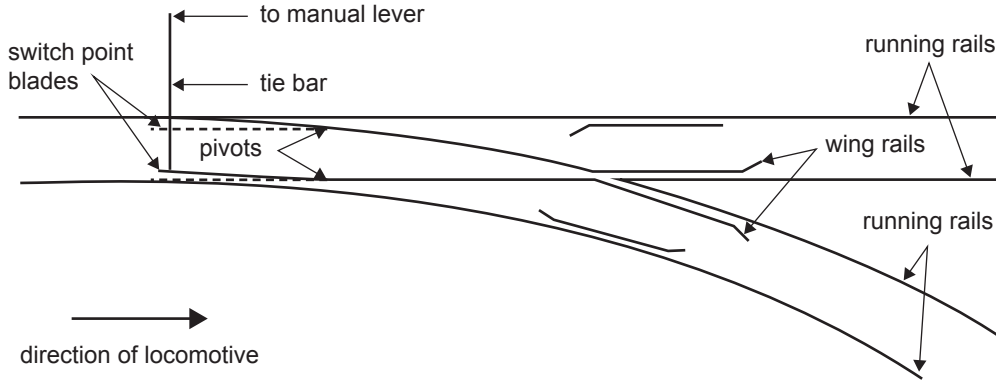

**Figure 2**

In order to operate the switch point blades, the tie bar is connected to a lever, as shown in Figure 3.

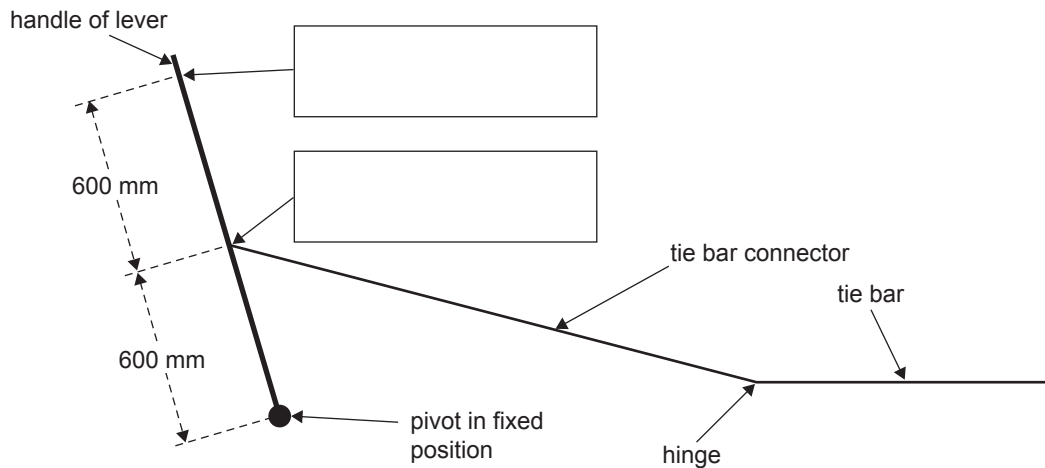

**Figure 3**

a. In the two boxes provided on Figure 3, enter the correct labels from the following list:

- effort
- load
- fulcrum

2 marks

b. Name the class of lever in Figure 3.

1 mark

- c. Using the layout shown in Figure 3, the force required to move the tie bar is 20 N.

Calculate the force Lucy needs to apply on the handle to move the tie bar. Show your working. 2 marks

---

---

---

N
---

- d. If the tie bar connector is now positioned 300 mm from the pivot, what will happen to the force required on the handle?

1 mark

---

**Question 4** (8 marks)

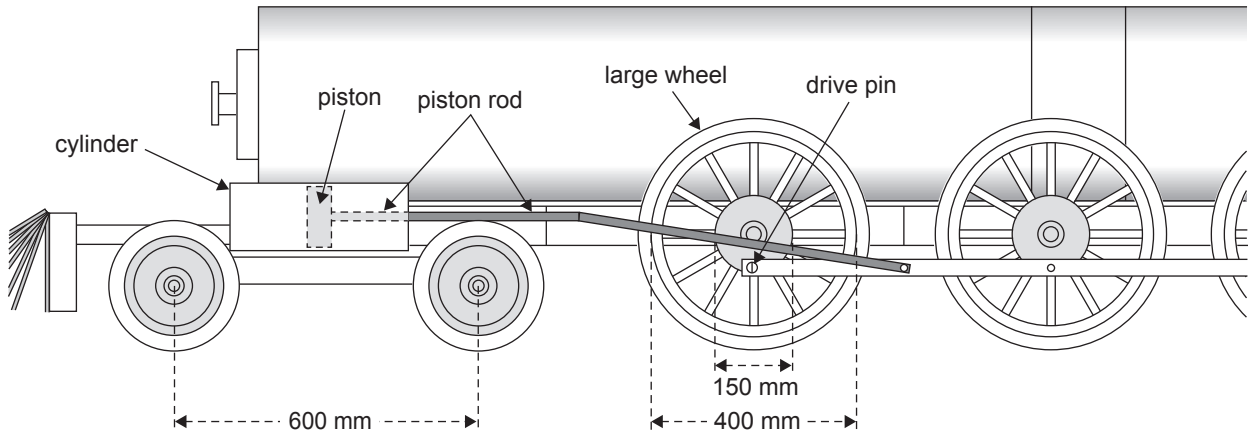

**Figure 4**

- a. What is the maximum length of the stroke of the piston in the cylinder in Figure 4? 1 mark

\_\_\_\_\_

mm

In Figure 4, the maximum force on each of the drive pins is 4000 N.

- b. Calculate the maximum torque of the large wheel. Show your working. 2 marks

\_\_\_\_\_  
 \_\_\_\_\_  
 \_\_\_\_\_

N m

- c. Calculate the maximum driving force of the wheels on the track. Show your working. 2 marks

\_\_\_\_\_  
 \_\_\_\_\_  
 \_\_\_\_\_

N

- d. The diameter of the piston is 100 mm.

Calculate the pressure on the left-hand side of the piston that is needed to produce a maximum force of 12 000 N to the driven wheels. Express your answer correct to the nearest kilopascal. Show your working.

3 marks

---



---



---



---

kPa
-----

**Question 5** (3 marks)

- a. Calculate the efficiency of the steam engine if, for every 600 J of energy in fuel, 60 J is converted to motion.

1 mark

---

%
---

- b. Give two factors that could affect the efficiency of the steam engine.

2 marks

1. \_\_\_\_\_

---

2. \_\_\_\_\_

---

**Question 6** (5 marks)

Lucy needs a design for a braking system that uses levers and rods that are in tension in order to stop the model steam locomotive.

- a. Using the diagram provided below, design a braking system that will apply both brake pads to the wheel using only rods that are in tension and will give a mechanical advantage of 24. Label the lengths of any levers that may affect the mechanical advantage. 4 marks

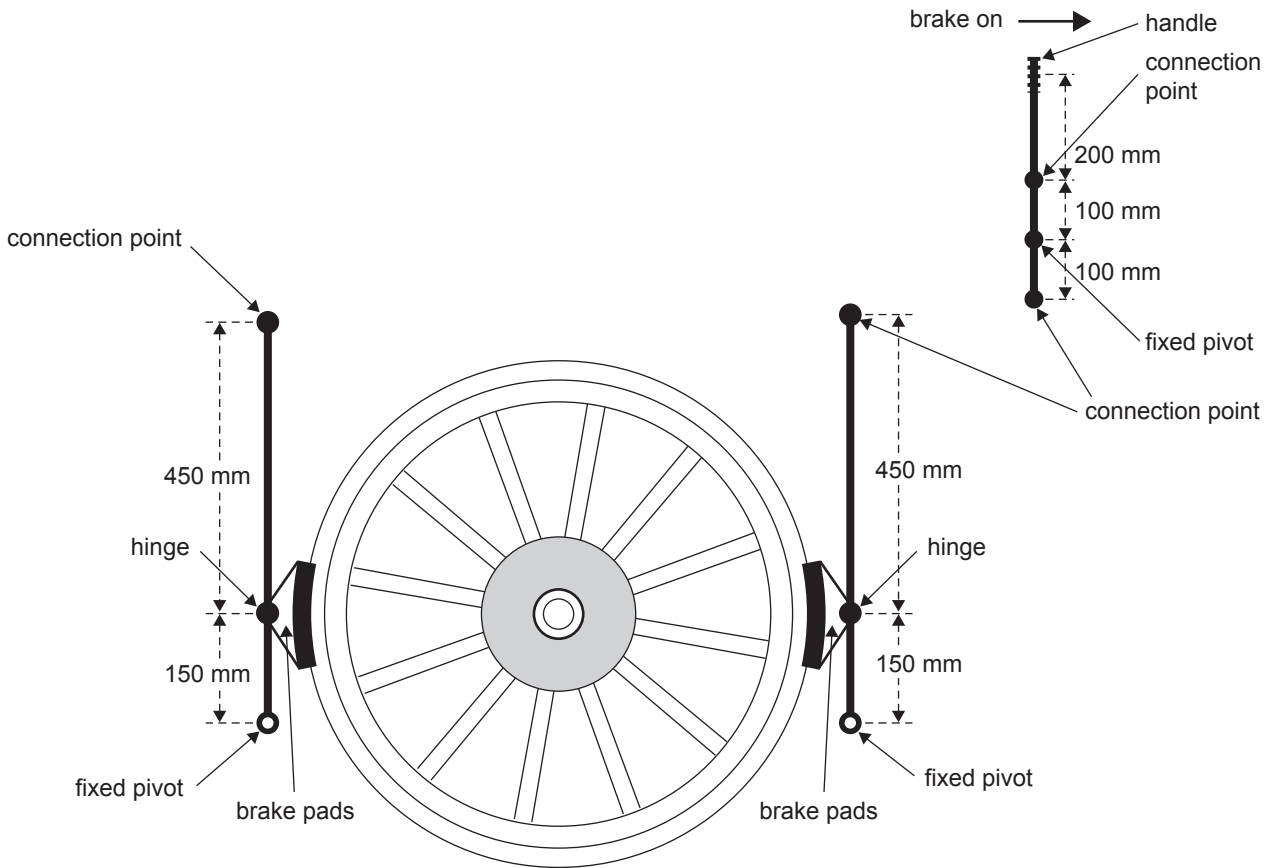

- b. Why should the rods be in tension rather than under compression when the braking system is applied? 1 mark

---



---

**Question 7** (2 marks)

Lucy wants to test the speed of the model steam locomotive. She decides to use a sound meter to record the difference in the time it takes for the first two wheels of the model steam locomotive to cross the join in the tracks. The two front wheels are 600 mm apart.

The graph in Figure 5a shows the peaks that represent the sound when each wheel hits a gap in the track.

Figure 5b shows the sound recorder set up with respect to the model steam locomotive and the train tracks.

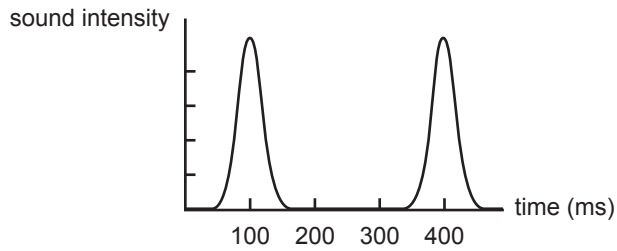
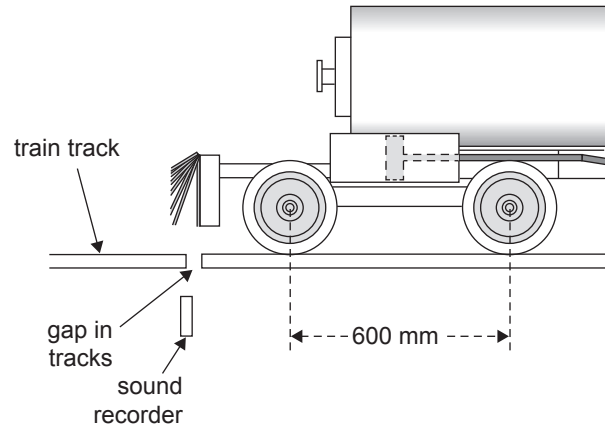
**Figure 5a****Figure 5b**

Use the graph in Figure 5a to calculate the speed of the model steam locomotive. Show your working.

---



---



---

$\text{ms}^{-1}$

**Question 8** (6 marks)

A walking track crosses the railway line, so Lucy plans to use a sensor that will detect the model steam locomotive as it approaches a boom gate that has flashing lights.

- a. 'Research feasibility and alternatives' is one of the stages of the Systems Engineering Process.

What is one factor that should be researched during the design of the system for the walking track crossing? Give your reasoning. 2 marks

Factor \_\_\_\_\_

Reason \_\_\_\_\_

- b. With respect to the Systems Engineering Process, explain the relevance of the 'design and model the system' stage for the walking track crossing. 2 marks

\_\_\_\_\_

\_\_\_\_\_

\_\_\_\_\_

\_\_\_\_\_

- c. At what stage of the Systems Engineering Process should evaluations take place and why? 2 marks

\_\_\_\_\_

\_\_\_\_\_

\_\_\_\_\_

\_\_\_\_\_



**Question 9** (2 marks)**Figure 6**

Figure 6 shows the design for a boom gate at the walking track crossing where the walking track crosses the railway line. Boom gates prevent people from walking onto the tracks and into the path of a train.

The mass of the boom in Figure 6 is 5 kg.

If the boom is in equilibrium, calculate the mass of the counterweight, given its distance from the pivot is 0.2 m. Ignore any mass of the boom that is to the left of the pivot. Show your working.

---

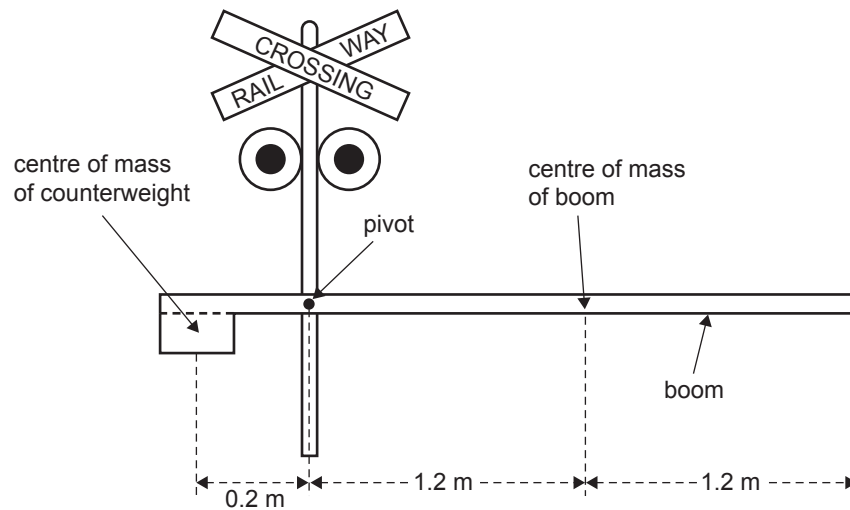

---



---

	kg
--	----

**Question 10** (5 marks)

Lucy plans to operate the boom with a 6 V stepper motor that rotates  $1.5^\circ$  for every pulse.

- a. If 50 pulses are sent to the stepper motor in order for the boom to rise completely, how many degrees will the boom rotate?

1 mark

---

°

- b. If it takes 10 s for the boom to raise or lower, what is the frequency of the pulses? Show your working.

2 marks

---



---



---

Hz

- c. Sketch a typical time voltage signal for the boom–stepper motor system on the axes provided below.

2 marks

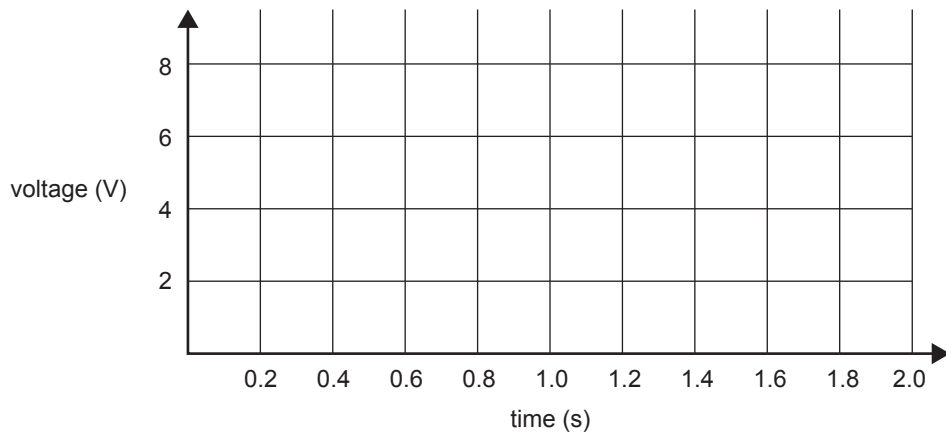

**CONTINUES OVER PAGE**

**Question 11** (6 marks)

Lucy wants to build an automated system to lower the boom at the walking track crossing and then raise it again after the train has passed the crossing. Figure 7 shows the plan for the automated system.

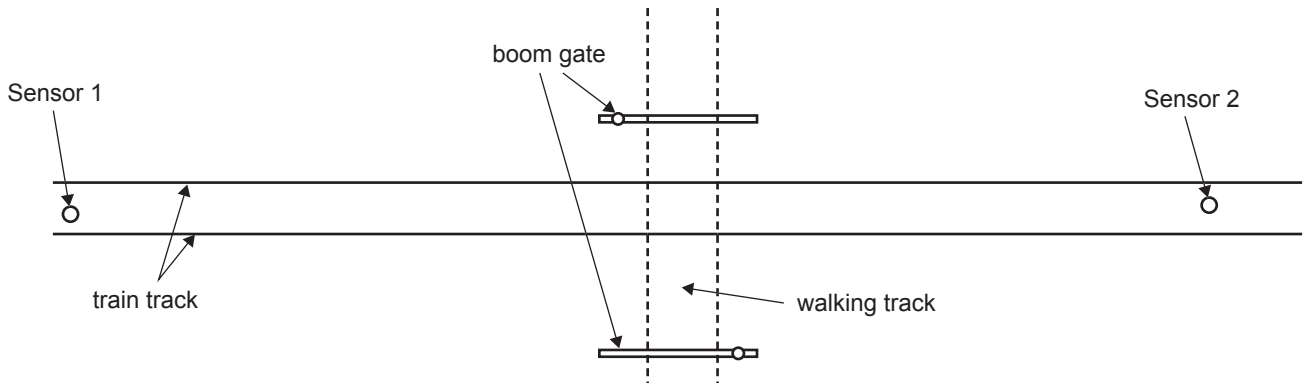

**Figure 7**

- a. How far should the sensors be placed from the walking track if the maximum speed of the train is  $3 \text{ ms}^{-1}$  and the lights operate for 15 s prior to the train crossing the walking track? Show your working.

2 marks

---



---



---

m

- b. Lucy wants to choose a sensor that has the ability to detect the train as it approaches the boom gate. Lucy's first thought was to use a light sensor.

Give a reason why a light sensor would **not** be appropriate in this situation.

1 mark

---



---

- c.** From the list below, circle another type of sensor that Lucy could use for the walking track crossing and state the advantage it would have over using a light sensor. 1 mark

piezo sensor

induction sensor

heat sensor

---

---

---

- d.** Describe how an electric signal would be produced in the sensor circled in **part c.** 2 marks

---

---

---

**Question 12** (14 marks)

Figure 8 shows a circuit diagram for the flashing lights at the walking track crossing.

Sensor 1 will turn the flashing lights on and Sensor 2 will turn the flashing lights off. The circuit is for the flashing lights only.

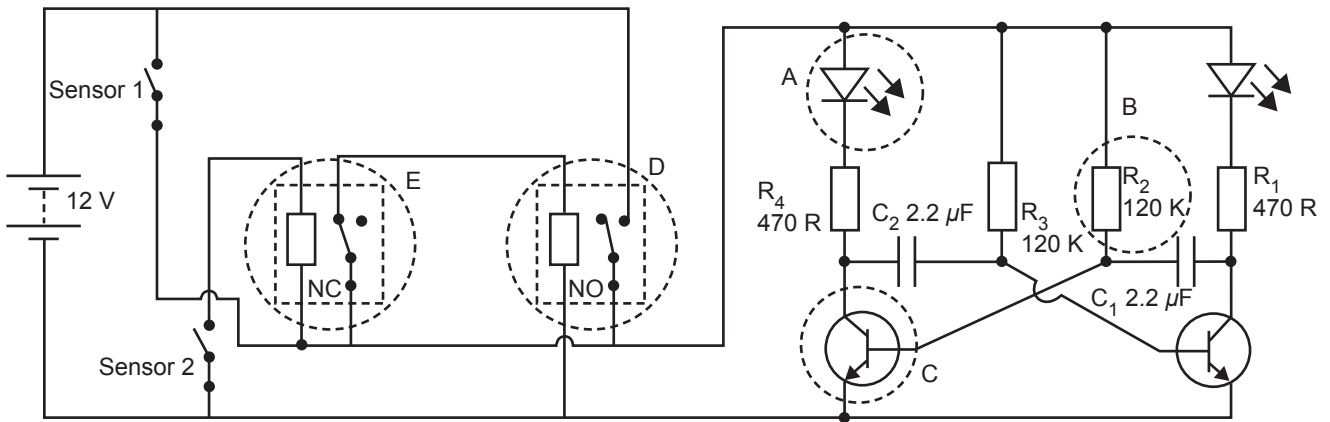

**Figure 8**

- a. In the table provided below, name each of the components A to D and give the specific purpose of each component in the context of the circuit diagram shown in Figure 8. 8 marks

Component	Name	Specific purpose of component
A		
B		
C		
D		

- b. As the steam engine passes Sensor 1, the switch in the sensor closes and the lights start to flash.

When Sensor 2 is activated, what will be the effect on components A, D and E in Figure 8? 3 marks

---



---



---



---



---



---

- c. An alternative to using the circuit diagram in Figure 8 is to use a programmable logic controller (PLC).

Draw a flow chart or write a program algorithm or pseudocode that will generate the two flashing lights that will be activated and deactivated by different sensors. Assume that as the model steam locomotive passes a sensor, the sensor output is high.

3 marks

**Question 13** (6 marks)

Lucy decides to have a light globe that operates continuously on her model steam locomotive. A simple circuit for the light globe is shown in Figure 9.

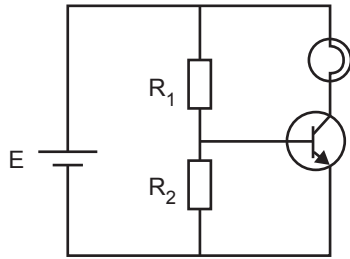
**Figure 9**

- a. In the space provided below, draw a circuit board for the circuit shown in Figure 9. 2 marks

**Circuit board**

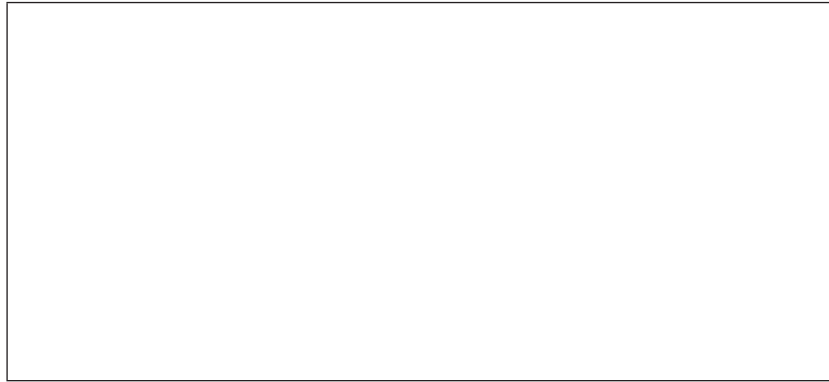

- b. On the circuit provided below, sketch and label a voltmeter that would measure the voltage of the power supply. 1 mark

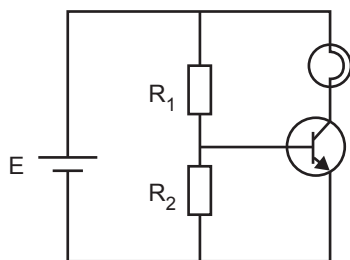



- c. If the total current in the circuit is 120 mA and the voltmeter reading is 12 V, what is the power output of the power supply? Show your working. 2 marks

---

---

---

W
---

- d. How many 1.5 V batteries connected in series would be needed for a power pack in order to produce 12 V? 1 mark

---

--

**Question 14** (8 marks)

On ‘total fire ban’ days, Lucy is unable to use solid fuel with her model steam locomotive. One option is to use a liquid biofuel.

- a.** Name two types of liquid biofuels that Lucy could use with her model steam locomotive. 2 marks

1. \_\_\_\_\_ 2. \_\_\_\_\_

- b.** Name two crops that are commonly used to produce biofuels. 2 marks

1. \_\_\_\_\_ 2. \_\_\_\_\_

- c.** Identify an ethical issue that could relate to using crops for biofuel and outline why it would be an issue. 2 marks

---

---

---

- d.** Lucy decides to use biofuel to generate an off-grid electricity supply.  
Explain how biofuel can be used to generate electricity. 2 marks

---

---

---

---

---

**Question 15** (5 marks)

The *Macquarie Dictionary* defines artificial intelligence as, ‘the ability of a computer or other device or application to function as if possessing human intelligence’.

If artificial intelligence were to be used in transportation, describe how a possible application would work and discuss the possible implications for society.

---

---

---

---

---

---

---

---

---

---



# **SYSTEMS ENGINEERING**

## **Written examination**

### **FORMULA SHEET**

#### **Instructions**

Please remove from the centre of this book during reading time.  
This formula sheet is provided for your reference.

**THIS PAGE IS BLANK**

## Systems Engineering formulas

gear ratio final = gear ratio 1 $\times$ gear ratio 2	efficiency = $\frac{\text{output energy}}{\text{input energy}} \times 100\%$		
gear ratio = $\frac{\text{number of teeth on driven gear}}{\text{number of teeth on driver gear}}$	efficiency <sub>Total</sub> = efficiency <sub>1</sub> $\times$ efficiency <sub>2</sub>		
$\frac{\text{gear A rpm}}{\text{gear B rpm}} = \frac{\text{number of teeth gear B}}{\text{number of teeth gear A}}$	mechanical advantage = $\frac{\text{load}}{\text{effort}}$		
$\frac{\text{pulley A rpm}}{\text{pulley B rpm}} = \frac{\text{radius of pulley B}}{\text{radius of pulley A}}$	force = pressure $\times$ area		
voltage = current $\times$ resistance	torque = force $\times$ distance		
power = voltage $\times$ current	frequency = $\frac{1}{\text{period}}$		
area of circle = $\pi r^2$ ( $\pi = 3.14$ )	speed = $\frac{\text{distance}}{\text{time}}$		
circumference of circle = $2\pi r$			
resistors in series	$R_t = R_1 + R_2 + R_3 + \dots$	capacitors in series	$\frac{1}{C_t} = \frac{1}{C_1} + \frac{1}{C_2} + \frac{1}{C_3} \dots$
resistors in parallel	$\frac{1}{R_t} = \frac{1}{R_1} + \frac{1}{R_2} + \frac{1}{R_3} \dots$	capacitors in parallel	$C_t = C_1 + C_2 + C_3 + \dots$
two resistors in parallel	$R_t = \frac{R_1 \times R_2}{R_1 + R_2}$		

### Colour codes

Colour	Value	Colour	Value
black	0	blue	6
brown	1	violet	7
red	2	grey	8
orange	3	white	9
yellow	4	gold	5%
green	5	silver	10%