



GENERAL COMMENTS

The 2011 Systems Engineering examination was based on all Areas of Study in Units 3 and 4 of the *VCE Systems Engineering Study Design*. The examination was based on the key knowledge and skills of the outcomes for Units 3 and 4. Students were required to answer all questions.

There was a good spread of marks, with all students achieving some success. The degree of difficulty of questions was similar across each of the main areas of the study design. Students who studied all areas of the study design had a clear advantage.

In Question 18, the diverse range of suggested solutions and the ingenuity of many of the students was impressive. Several of the other questions relied on students being able to read and interpret simple technical diagrams. These were also well done.

Significant figures and decimal places were an issue. As a general rule, students should treat the information given as exact values unless otherwise stated. They should be able to give answers correct to a given number of decimal places or significant figures when directed. All answers should be in the appropriate units.

Students should also look at the number of marks allocated to each question. If more than one mark is allocated, then appropriate working or information must be given.

Section A – Multiple-choice questions

Question	% A	% B	% C	% D	% No Answer	Comments
1	19	26	50	5	0	
2	2	2	47	49	0	The fulcrum must be at Y and the effort at X. Some students did not recognise the lever defined by the points W, X and Y.
3	14	32	48	7	0	Mechanical advantage = $\frac{\text{load}}{\text{effort}}$. If the load was 1 N, the effort would be 4 N (using force \times distance), therefore mechanical advantage = $\frac{1}{4}$. Many students did not realise that it is the distance from the fulcrum that is important. The distance from the load to the fulcrum is 200 cm, not 150 cm.
4	13	30	14	43	0	Driven to driver is 11:4. The gears both go in the same direction.
5	18	24	20	39	1	Gear ratio = $\frac{\text{driven gear}}{\text{driver gear}}$ or driven: driver. In compound gears, the total ratio is the product of the individual gear ratios. Gear ratio = $\frac{1}{3} \times \frac{1}{5} = \frac{1}{15}$ or 1:15
6	3	14	6	76	0	Pulley C has half the diameter so will spin twice as fast. It will also go in the opposite direction to pulley A and pulley B.
7	5	87	6	3	0	Assembling and construction are not maintenance processes.
8	63	4	2	31	0	The MSDS gives all the precautions necessary. The instructions on the label explain how to use the chemical.

2011 Assessment Report



Question	% A	% B	% C	% D	% No Answer	Comments
9	6	6	53	35	0	Closing the switch will generate a larger amount of current to flow through the circuit. As there is a resistor in the circuit, the voltage drop across the resistor will increase, hence less voltage across the motor. Motor 1 will rotate at a slower speed.
10	22	40	21	17	0	A transducer transforms energy from one form to another; for example, a microphone or a speaker.
11	39	36	14	11	0	If R2 is shorted, there will be only one load, that is R1. The voltage across R1 will then be 12 volts. If R1 is shorted, the voltage across it will be 0 volts.
12	7	30	56	8	0	The signal takes 4 divisions on the horizontal scale for a complete cycle. $4 \times 0.05 = 0.2$ s. The frequency is $\frac{1}{\text{period}} = \frac{1}{0.2} = 5$ Hz. The amplitude is 2 divisions. $2 \times 5 = 10$ volts.
13	23	51	14	11	0	A resistor and a diode in series will give half-wave rectification.
14	58	24	6	12	0	$R = \frac{V}{I}$. As the voltage drop for green is lower, the resistance is also lower.
15	4	10	8	78	0	
16	4	55	4	38	0	
17	12	2	76	10	0	
18	6	61	24	9	0	
19	7	7	5	81	0	Light is entering a resistor.
20	33	18	16	33	0	If both input A and input B are 0, the AND gate will give a 1 and hence the OR gate will be 1. Hence the answer was D.

Section B – Short answer questions

Question 1

Marks	0	1	Average
%	17	83	0.8

Most students correctly identified that the handle should be turned anticlockwise.

Question 2

Marks	0	1	Average
%	31	69	0.7

Linear

Question 3

Marks	0	1	2	Average
%	52	33	15	0.7

- gravitation potential energy (answering either gravitational or potential was also accepted)
- moving energy (kinetic energy)

Mechanical energy was not accepted.

Question 4

Marks	0	1	2	Average
%	29	16	55	1.3

2011 Assessment Report



Torque = force \times distance or $T = 400 \times 0.2$
80 Nm

Question 5a.-b.

Marks	0	1	2	3	4	Average
%	33	8	27	6	25	1.8

5a.

(Gear A rpm)/(Gear B rpm) = (number of teeth on gear B)/(number of teeth on gear A) or $24/B = 16/8$

Gear B rpm = 12

5b.

The circumference of the wheel is given by: $c = 2 \times 3.14 \times 0.1$ or $c = 0.628$

As the rpm is 12, the distance travelled is $12 \times 0.628 = 7.54$ m

Students needed to give the units in this question.

Question 6

Marks	0	1	2	Average
%	31	41	29	1

They have a valid complaint. As the radius of the cable drum effectively increases, so does the effort.

Question 7

Marks	0	1	2	Average
%	47	28	26	0.8

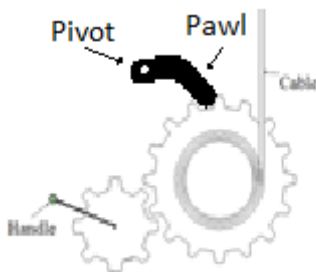

For full marks, students needed to have the sketch of the pawl, the labelling and the orientation correct.

Question 8

Marks	0	1	Average
%	22	78	0.8

To increase efficiency. Less effort is required to raise the elevator.

Question 9

Marks	0	1	Average
%	32	68	0.7

The elevator will not go down. The elevator will rise.

Question 10

Marks	0	1	2	Average
%	55	6	39	0.9

Any of:

- $\text{Eff} = (\text{output energy})/(\text{input energy}) \times 100\%$
- $0.85 = (\text{output energy})/3000 \times 100\%$
- 85% of 3000.

2011 Assessment Report



2550 W or 2.55 kW if the unit is not specified in the question then the answer must be given in the base unit. (In this case, 2550 or 2.55 k was accepted. An answer of 2.55 was not acceptable.)

Question 11

Marks	0	1	2	Average
%	50	9	42	0.9

Any of:

- $P = V \times I$
- $I = P/V$
- $I = 3000/240$
- $I = 12.5A$.

Question 12

Marks	0	1	2	3	Average
%	19	25	29	27	1.7

- input: electricity
- subsystem 1: electric motor
- subsystem 2: gear box

Question 13

Marks	0	1	2	Average
%	42	19	39	1

An example of a diagnostic test to determine the gear ratio of the gearbox is: Count the rotations of the shaft to the electric motor until the shaft to the drum rotates once.

Students should have referred to using the formula.

Question 14

Marks	0	1	Average
%	33	67	0.7

Tension

Question 15

Marks	0	1	2	Average
%	10	39	51	1.4

If the cable breaks, the compression springs will expand. This will cause the bell crank to rotate and, in turn, the latch moves out and catches on the elevator shaft.

Question 16

Marks	0	1	2	3	Average
%	42	23	22	13	1.1

Any of:

- $area = \pi r^2$
- $area = 0.0707m^2$

Force = Pressure \times area. Stating only the formula was not enough.

$$F = 120000 \times 0.0707$$

$$Force = 8483 \text{ N}$$

2011 Assessment Report



Question 17a–b.

Marks	0	1	2	Average
%	43	36	21	0.8

17a.

The purpose of the one-way valve is to stop backflow through the motor when it is not in operation.

17b.

The elevator cage will go down.

Question 18a.–b.

Marks	0	1	2	3	4	Average
%	31	10	23	6	29	1.9

18a.

The simplest response showing a motorised opening and closing mechanism is shown below, but there was a wide variety of correct answers given.

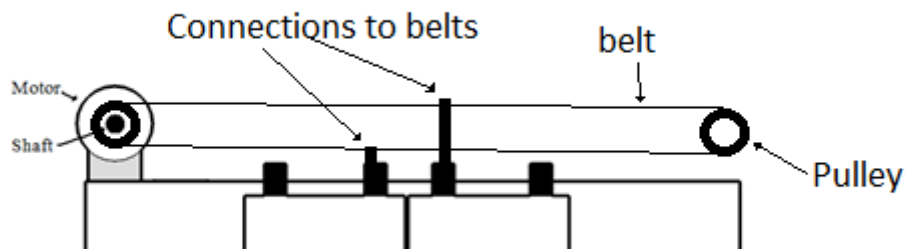

Many answers to this question were impressive.

18b.

The description needed to match the diagram. Most students who got two marks for 18a. also got two marks for 18b.

Question 19

Marks	0	1	Average
%	34	66	0.7

The majority of students correctly identified the location of the two contact switches (shown on the diagram below as 'X').

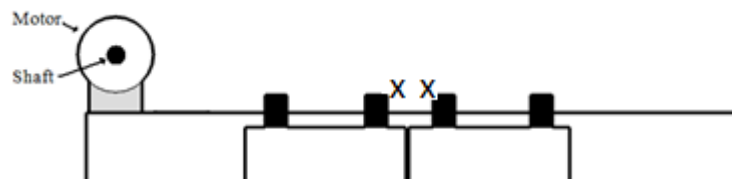

2011 Assessment Report



Question 20

Marks	0	1	2	Average
%	30	19	51	1.2

A possible answer is given below. All components and switches should be in series.

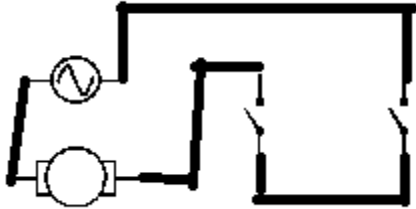

Question 21

Marks	0	1	Average
%	69	31	0.3

The voltmeter needs to be in parallel with the supply. In this case, a voltmeter across the motor was accepted, as the voltage drop across the wires is not considered in this course.

Question 22a.–b.

Marks	0	1	2	Average
%	63	10	27	0.7

22a.

A magnetic switch or LDR are two possible examples.

22b.

This answer must have explained the operation of the electrical component provided in Question 22a.

Question 23a.–b.

Marks	0	1	2	Average
%	26	47	27	1

23a.

Light Emitting Diode (LED)

23b.

In the context of the given circuit, the LED is to show that the elevator has been called.

Question 24

Marks	0	1	2	Average
%	46	31	23	0.8

- input: door switch
- output: door motor or LED to show the call has been recorded

Question 25

Marks	0	1	Average
%	21	79	0.8

Starting from the left and going clockwise on the flowchart, the correct answer was 1, 3, 2.

Question 26

Marks	0	1	Average
%	18	82	0.8

2011 Assessment Report



Most students correctly identified segments a, b and c.

Some students also included segment f.

Question 27

Marks	0	1	2	Average
%	55	41	5	0.5

The correct connections between the seven-segment display and the 4511 integrated circuit are shown below.

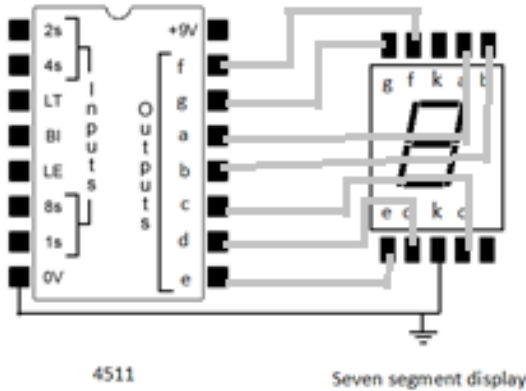

Question 28a.–b.

Marks	0	1	2	3	4	Average
%	41	19	18	11	11	1.3

28a.

NPN transistor

For full marks students needed to state both the name and type of the component.

28b.

Two applications for this component are as an amplifier or switch.

Question 29a.–b.

Marks	0	1	2	3	Average
%	43	13	25	19	1.2

29a.

A polarised capacitor or electrolytic capacitor

29b.

This component is used to store charge or for a timing circuit or to smooth current.

Question 30

Marks	0	1	Average
%	64	36	0.4

The colour code of the 2K2 resistor with a 5% tolerance is: red, red, red, gold.

Some students gave the colour code for five bands. This was accepted as long as the final colour was gold (red, red, black, brown, gold).

Question 31

Marks	0	1	2	Average
%	32	9	59	1.3

2011 Assessment Report



A correctly labelled drawing to show resistors in series to replace the 2K2 resistor is shown below. Students needed to use some of the listed resistors.

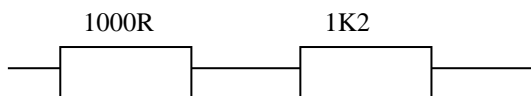

Question 32

Marks	0	1	2	Average
%	37	32	31	1

A correctly labelled drawing to show resistors in parallel to give the closest possible value to 2K2 is shown below.

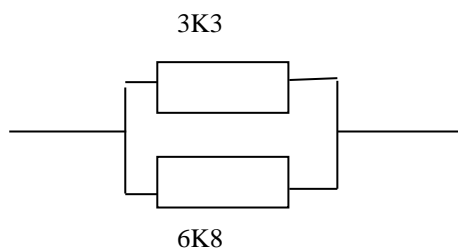

Question 33

Marks	0	1	2	Average
%	48	17	35	0.9

Many different options for reducing the energy consumption of the lighting in the lift were suggested. The simplest was to remove two of the four globes. Light sensors, LEDs and fluorescents were commonly suggested. The second mark was given for the justification of how the energy reduction would be achieved.