



2007 VCE VET Furnishing GA 2: Written examination

GENERAL COMMENTS

In 2007, the number of students sitting for the VCE VET Furnishing written examination increased from the previous year from 199 to 266. The questions on the examination were designed to test students' underpinning knowledge of the seven competencies they had studied in Units 3 and 4 as part of the VCE VET program.

Areas of strength

- ability to answer multiple-choice questions
- completing a cutting list
- occupational health and safety

Areas of weakness

- basic mathematics (calculations, dimensions, costing, etc.)
- hardware and construction knowledge
- work plans
- cutting plans

SPECIFIC INFORMATION

Section A – Multiple-choice questions

The table below indicates the percentage of students who chose each option. The correct answer is indicated by shading.

Question	% A	% B	% C	% D	Comments
1	72	2	26	0	
2	16	9	36	39	Although option C contained the correct total number of doors, it was incorrect as length is always with the grain and length is always quoted first in a size, even if the length is shorter than the width.
3	32	16	16	36	Raw medium density fibreboard (option D) is specially designed to take a paint finish as one of its several inherent qualities, therefore this was the correct answer.
4	8	91	0	1	
5	20	47	11	23	
6	54	45	1	0	
7	0	0	4	96	
8	28	27	29	16	Although option A (back sawn board) was considered to be the correct response, option C (quarter sawn board) was also allowed as some quarter sawn boards may display figure, albeit in straight lines. Nevertheless, there are a number of other reasons why back sawn board would be the most correct material for use for a solid timber table top. It can be argued that back sawn boards produce true figure whereas quarter sawn boards produce straight grain on the face of the board.
9	6	48	19	26	
10	24	10	59	7	
11	46	19	4	31	
12	7	7	77	8	
13	46	18	9	25	As in many of the mathematics related questions, the students who selected option A did not calculate the total for two sheets of board product.
14	32	54	5	9	
15	9	70	13	7	

2007 Assessment Report



Question	% A	% B	% C	% D	Comments
16	86	6	5	2	
17	1	0	85	13	
18	87	10	0	2	
19	16	21	58	4	
20	26	9	22	43	It appeared that the knowledge required for this question had not been tested in the classroom. Schools will have smoothing planes and jack planes, and although many will not have try planes, rebate planes or compass planes, the information is freely available in the resources for this competency.

Section B – Short answer questions

Question 1

Marks	0	1	Average
%	15	85	0.9

A cutting list

Question 2

Marks	0	1	Average
%	39	61	0.6

Read the Materials Safety Data Sheet (MSDS)

Question 3

Marks	0	1	2	Average
%	3	37	60	1.6

Acceptable responses included any two of:

- so all parts are listed and can be machined to size
- to indicate the materials to be used
- to identify any special machining requirements
- to list the name and number of items to be made
- to indicate how many of each component.

Question 4

Marks	0	1	2	3	4	Average
%	5	5	15	29	47	3.1

- A: side rail
- B: dowels
- C: leg
- D: end rail

Question 5

Marks	0	1	2	3	Average
%	74	14	0	12	0.5

There were three elements to the calculation, each of which was allocated one mark.

- each leg had 15 mm added for a docking allowance – $(865 + 15 = 880 \text{ mm})$
- translate each piece of material into metres and multiply by two for one chair – $(0.880 \times 2 = 1.760 \text{ m})$
- multiply by 10 to enable 10 chairs to be done to order – $(1.760 \times 10 = 17.60 \text{ lineal metres})$

Question 6

Marks	0	1	2	Average
%	57	11	32	0.8

Two separate calculations were required, with one mark allocated to each.

- for one bookcase, multiply the length in metres by the width in metres – $(1.160 \times 0.914 = 1.06024 \text{ m}^2)$
- for nine bookcases, multiply by nine – $(1.06024 \times 9 = 9.54216 \text{ or } 9.542 \text{ m}^2)$

2007 Assessment Report



Question 7

Marks	0	1	2	3	Average
%	0	1	19	81	2.8

Personal protective equipment items to be used included:

- eye protection (safety glasses)
- hearing protection (ear plugs, ear muffs)
- dust mask.

Question 8a.

Marks	0	1	Average
%	19	81	0.8

$$\frac{1770}{6} = 295 = \$295.00$$

Question 8b.

Marks	0	1	Average
%	38	62	0.6

$$\frac{295.00}{6.5} = 45.384615 = \$45.38$$

Question 9a.

Marks	0	1	Average
%	15	85	0.9

- 1. 80 grit
- 2. 100 grit
- 3. 150 grit
- 4. 240 grit

Question 9b.

Marks	0	1	2	Average
%	33	35	32	1.0

Abrasive grit paper

- 40grit
- 60 grit

Fine-finishing grit paper

- 180 grit
- 220 grit
- 320 grit
- 400 grit

Question 10

Marks	0	1	2	Average
%	17	50	33	1.2

The most important checks to make included any two of:

- that the door is diagonally square
- that the door is not in 'twist or wind'
- that the stiles and rails are 'flat' or on the same plane, sometimes referred to as 'straight'.

Question 11

Marks	0	1	2	Average
%	57	12	31	0.7

2007 Assessment Report

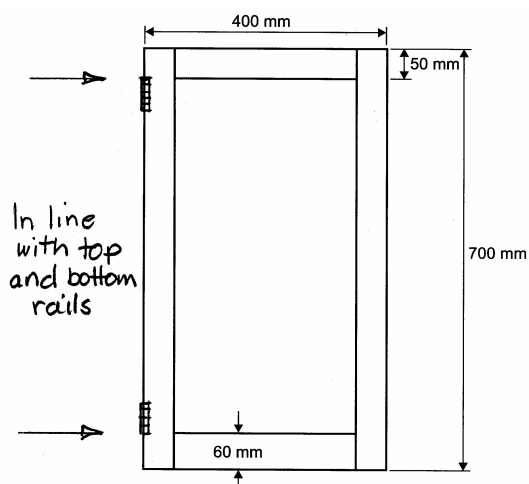

The correct position(s) for brass hinges on a framed solid timber door, as shown above, are:

- in line with the bottom of the top rail on either the left or right stile. The top rail in this case was 50 mm
- in line with the top of the bottom rail on either the left or right stile. The bottom rail in this case was 60 mm.

Note: where there is a solid panel door then the length/position of the hinge above or below the top or bottom is the length of the hinge being used. The reason a wider bottom rail is used on a framed door is one of perspective. The bottom rail will look less narrow when viewed from a 'standing' height.

Question 12a.

Marks	0	1	2	3	Average
%	5	7	41	47	2.3

Acceptable items of hardware included:

- brass butt, semi concealed, hipline hinge
- handle or knob
- magnetic, ball or double ball catch.

One mark was awarded for a description of each piece of hardware.

Question 12b.

Marks	0	1	Average
%	65	35	0.4

Either of:

- iron on ash veneer tape
- solid ash timber glued and clamped to the edge.

This question was not answered well.

Question 12c.

Marks	0	1	Average
%	45	55	0.6

Either of:

- adjustable shelf pin or support
- shelf ferrule or bush.

Question 12d.

Marks	0	1	2	3	4	5	6	7	8	9	10	Average
%	13	5	4	6	3	7	9	17	12	11	13	5.7

2007 Assessment Report

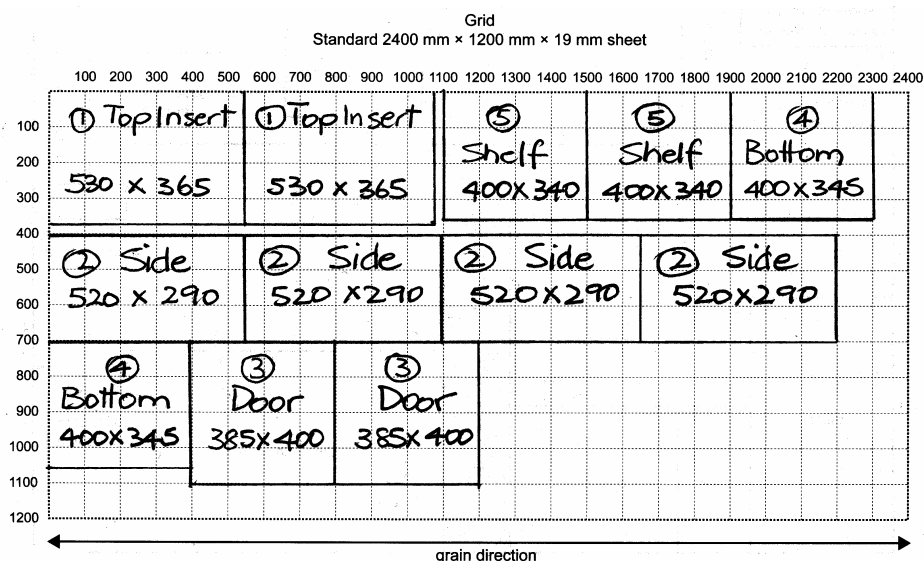

The 10 marks were awarded as follows:

- 12 items correctly set out (five marks)
- scale and grain direction (two marks)
- economical use of the material, which includes ease of cutting (one mark)
- sizes marked correctly (one mark)
- components identified correctly (one mark).

Question 13a.

Marks	0	1	Average
%	9	91	0.9

The three most relevant signs were:

- B. dust mask
- D. safety glasses
- E. ear protection.

Question 13b.

Marks	0	1	Average
%	10	90	0.9

- A. hand protection, safety gloves
- C. half face respirator
- D. safety glasses

Question 13c.

Marks	0	1	Average
%	10	90	0.9

Acceptable responses included any of:

- so when the sheets are delivered they are easily and quickly stored
- so all the storage is in one place, making the work area more organised rather than having goods everywhere
- to reduce the distance the sheets are carried when unloading from the truck
- so that the sheet material store is handy to the machining area for easy breakdown.

Question 13d.

Marks	0	1	2	Average
%	15	61	24	1.1

Appropriate manual handling devices included any two of:

- flat topped four wheel trolley
- hand held board support (using two people to lift)
- hand operated forklift

2007 Assessment Report



- portable skates
- table trolley
- pallet trolley.

Students were awarded two marks for providing two suitable responses.

Question 13e.

Marks	0	1	2	Average
%	2	36	62	1.6

Acceptable answers included any two of:

- it is close to both the assembly and finishing areas
- it is near the work areas where tools and hardware are required, which would save time
- it is out of the way in assembly and finishing areas
- it is an easy area to access.

Section C – Case study questions

Question 1

Marks	0	1	2	3	4	5	6	7	8	9	10	Average
%	1	1	1	7	15	21	21	13	11	9	1	5.8

Cutting list for the plantation grown cedar bedside table

Item	No. of pieces	Length	Width	Thickness	Material	Remarks
leg	4	620	40	25	cedar	dowelled to all rails
top insert	1	530	365	19	cedar VPB	
top facing (front)	1	640+	55	20	cedar	
top facing (side)	2	420+	55	20	cedar	
side rail	2	290	135	19	cedar VPB	dowelled to legs
back rail	1	540	135	19	cedar VPB	dowelled to legs
back/front stretcher	2	540	35	20	cedar	dowelled to legs
side stretcher	2	290	35	20	cedar	dowelled to legs
drawer front	1	540	135	19	cedar	grooved for ply bottom
drawer side	2	302	95	12	hoop pine	grooved for ply bottom
drawer back	1	540	77	12	hoop pine	top edge set down 6 mm and rounded over
drawer bottom	1	524	294	4	hoop pine plywood	
drawer rail	2	540	50	20	hoop pine	dowelled to leg and side rail
drawer runner	2	270	20	20	hoop pine	

All correct answers are highlighted in the cutting list above. One mark was awarded for each missing specification.

Question 2

Marks	0	1	2	3	4	Average
%	26	22	18	17	16	1.8

Students were awarded up to four marks for the depth of knowledge shown in the task set. An example is shown below.

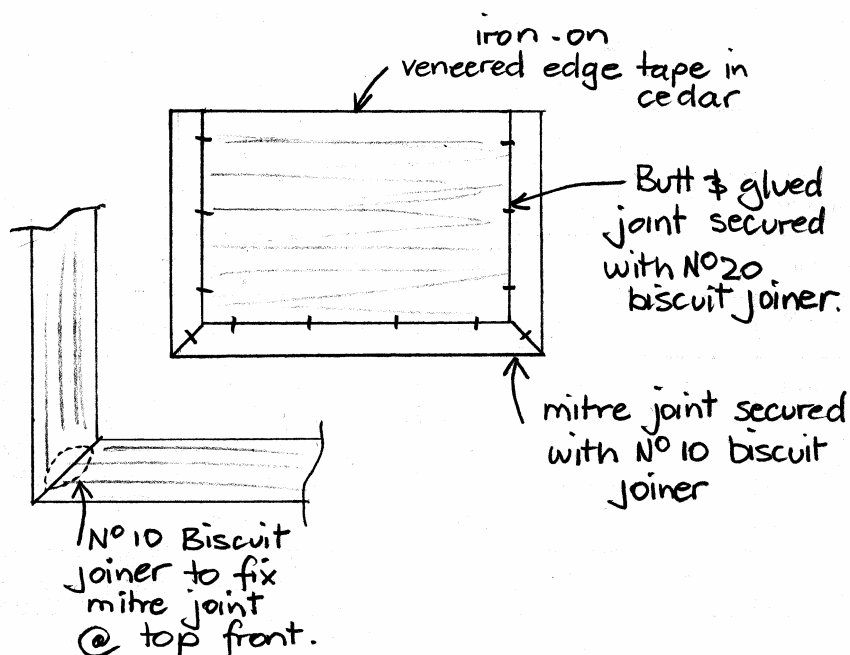

Construction details

- all facings joined to the veneered particle board inset using PVA adhesive and No. 20 biscuit joiners
- front and side facings mitred at the front of the top and to be joined using PVA adhesive and No. 10 biscuits
- top screwed to the carcass through the drawer rail, pocket screwed through the back rail, screwed through
- cleats attached to the side rails and/or back rails and/or fixed with metal angle brackets where appropriate

Work plan

- mitre front and side facings to top inset length and width, allow slightly longer at back to trim later
- apply cedar veneered edging tape to back of top inset, flush all edges as required
- use biscuit joiner to cut grooves to fit No. 20 biscuits to the top inset/top side and front facings
- cut grooves for No. 10 biscuits for the front mitre joints
- use PVA adhesive to clamp and assemble all parts of the top together, clean up excess glue after clamping
- flush, trim and clean up top ready for fixing to the bedside table carcass
- prepare clearance holes to fix top, making sure top of the carcass is flush; plane flat if required
- countersink/counter bore or prepare pocket screw for back or side rails
- clamp top in place using protective blocks to avoid damage to top and drill pilot holes for screws
- fix screws in place and remove clamps

Question 3

Marks	0	1	2	3	4	5	Average
%	53	6	22	4	3	13	1.4

There were five elements to the overall result, with each element being awarded one mark.

- legs 2.7 metres of (50 mm × 38 mm) @ \$4.62 per lineal metre – (2.7 × 4.62 = 12.474 = \$12.47)
- top insert (convert millimetres to metres) (0.530 m × 0.365 m = 0.19345 m² × \$33.52 m² = 6.484444 = \$6.48)
- top facings 1.6 metres of (75 mm × 25 mm) @ \$4.58 per lineal metre (1.6 × 4.58 = 7.328 = \$7.33)
- back/side rails (convert millimetres to metres) (1.040 m × 0.135 m = 0.1404 m² × \$33.52 m² = 4.706208 = \$4.71)
- total cost (12.47 + 6.48 + 7.33 + 4.71 = 30.99 = \$30.99)

This question was not answered well by the majority of students. Generally, students confused the product size information in the costing process.

2007 Assessment Report



Question 4

Marks	0	1	2	3	4	5	6	7	8	Average
%	12	8	17	19	12	8	11	5	7	3.4

Below is an example of the work plan steps.

- 2. Check all components for correct size from cutting list; mark out for dowels on legs and all back, side, drawer rails and stretchers. Drill all dowel holes and dry check for fit. Prepare all components for assembly by sanding and finishing where appropriate.
- 3. Assemble ends of bedside table including legs, end rails and side stretchers. Check for diagonally square, twist and wind and straight. Clean up all glue residue. Then when dry assembling the carcass, again check for diagonally square in both plan and elevation, paying particular attention to the drawer rails that they are parallel to the top of the carcass. Clean off all glue residue and leave until dry.
- 4. Fit all drawer runners and flush off and clean up the carcass, drill all holes in preparation to fix the top. Prepare the drawer components by trial fitting and machine dovetail the drawer. Clean up the material and assemble the drawer and leave it to dry in the space where it will be fitted when dry.
- 5. Prepare top by attaching veneer edge tape to back of top, then biscuit join all joints ready to assemble. Assemble as per work plan in Question 2. Allow to dry. When dry, fit drawer and drawer bottom. Clean up top by trimming, flushing and sanding all seen surfaces. Prepare carcass for top by flushing top of carcass and attach top (see method in Question 2), then final fit the drawer.

Two marks were available for each major step. The first and last steps were completed as a guide, so students were to complete steps 2–5.

Question 5

Marks	0	1	2	3	4	5	6	7	8	Average
%	9	3	9	6	8	10	20	14	21	5.1

Below are some examples of appropriate responses.

- Marking gauge: Used to mark out dowel location points prior to drilling on the dowelling machine. The gauge is used to mark out the legs, side, back and stretcher rails of the bedside table carcass. The gauge has a sharp marking point that enables an adjustable sliding block to be set at a particular distance from an edge, end or side of a component to mark out centre points to help guide the dowel bit.
- Smoothing plane: Used to clean up machine marks and flush joints after assembling the various parts of the bedside cabinet; for example, flush top and front facings to the top insert before finish sanding the top prior to attaching to the carcass. The smoothing plane needs to be sharp to be of use as a blunt blade not set correctly can also do damage. Can also be used to remove machine marks on dressed timber prior to cleaning up.
- Sash cramp: Used to assemble all parts of the bedside table carcass. It is used with appropriate wooden cramping blocks to enable an accurate result to occur that includes helping to make the assembly diagonally square by fine adjustment up and down, parallel, straight (components on the same plane) and to avoid 'twist and wind'.
- Small tenon saw: Used to cut out dovetails for the drawer if this is called for. The saw is used to cut the pins and sockets prior to using a chisel to clean out the sockets and paring and fitting the pins to the sockets. It can also be used to cut dowel to length to assemble the carcass if pre cut dowels are not available.

Other hand tools that could be used included a chisel, large steel rule, mallet, try square, sanding cork or block, tape measure and screw driver.

Two marks were available for each process conveyed and how the tool was used in the process. This question was answered well by students generally.