

**Victorian Certificate of Education  
2015**

SUPERVISOR TO ATTACH PROCESSING LABEL HERE

STUDENT NUMBER           Letter

**VCE VET MUSIC  
TECHNICAL PRODUCTION**

**Aural and written examination**

**Tuesday 17 November 2015**

**Reading time: 9.00 am to 9.15 am (15 minutes)**

**Writing time: 9.15 am to 10.45 am (1 hour 30 minutes)**

**QUESTION AND ANSWER BOOK**

**Structure of book**

<i>Section</i>	<i>Number of questions</i>	<i>Number of questions to be answered</i>	<i>Number of marks</i>
A	10	10	25
B	19	19	75
			Total 100

- Students are permitted to bring into the examination room: pens, pencils, highlighters, erasers, sharpeners and rulers.
- Students are NOT permitted to bring into the examination room: blank sheets of paper and/or correction fluid/tape.
- No calculator is allowed in this examination.

**Materials supplied**

- Question and answer book of 15 pages.
- An audio compact disc will run continuously throughout Section A of the examination. The audio compact disc will run for 23 minutes 41 seconds.

**Instructions**

- Write your **student number** in the space provided above on this page.
- You may write at any time during the running of the audio compact disc and after it stops.
- Answer **all** questions in the spaces provided.
- All written responses must be in English.

**Students are NOT permitted to bring mobile phones and/or any other unauthorised electronic devices into the examination room.**

**SECTION A****Instructions for Section A**

The audio compact disc plays throughout Section A. In **Questions 1–10**, audio excerpts are played twice.

The announcer explains how the audio excerpt(s) for each question will be played.

**Question 1** (4 marks)

Identify which of the following tones are being played after the reference tone of 1 kHz:

125 Hz, 250 Hz, 1 kHz, 2 kHz, 4 kHz, 8 kHz

a. \_\_\_\_\_

b. \_\_\_\_\_

c. \_\_\_\_\_

d. \_\_\_\_\_

**Question 2** (3 marks)

Identify which of the following waveforms are being played:

sine, square, triangle, sawtooth, white noise, pink noise

a. \_\_\_\_\_

b. \_\_\_\_\_

c. \_\_\_\_\_

**Question 3** (3 marks)

The following saxophone excerpt has two parts. Both parts use the same kind of effect.

a. What effect has been used in both parts? 1 mark

\_\_\_\_\_

b. What parameter has been changed in the second part? 1 mark

\_\_\_\_\_

c. In what way has the parameter been changed? 1 mark

\_\_\_\_\_

**Question 4** (3 marks)

The following drum loop excerpt is in three parts. The first part has had no effect added. The second and third parts have had the same kind of effect added to them.

- a. What effect has been added to the second and third parts? 1 mark

---

- b. What parameter of the effect has been changed in the third part? 1 mark

---

- c. In what way has the parameter been changed? 1 mark

---

**Question 5** (2 marks)

The following drum loop excerpts are in two parts. The second part of each excerpt has had an equaliser filter applied.

Name the kind of equaliser filter used in each.

- a. \_\_\_\_\_

- b. \_\_\_\_\_

**Question 6** (2 marks)

There are problems with the sound of the vocal microphone through a PA system. The microphone, desk and speakers are working normally.

- a. Describe the audible problems. 1 mark

---

- b. Which item in the signal path is most likely to be the cause of the problems? Suggest a solution. 1 mark

---

**Question 7** (5 marks)

- a. The following excerpt is in two parts.

Describe which aspect of the mix has been changed in the second part.

1 mark

---

- b. The following excerpt is in two parts.

Describe which aspect of the mix has been changed in the second part.

1 mark

---

- c. The following excerpt is in two parts.

Describe which aspect of the mix has been changed in the second part.

1 mark

---

- d. The following excerpt is in two parts.

Describe what effect has been added.

1 mark

---

- e. The following excerpt is in two parts.

Describe which aspect of the mix has been changed in the second part.

1 mark

---

**Question 8** (1 mark)

The following excerpt is in two parts.

What digital signal process has been applied to the second part?

---

**Question 9** (1 mark)

The following excerpt is of an acoustic guitar in a live venue with two microphones pointed at it. The excerpt is in two parts. The second part contains an audible phase-related issue.

Suggest what change could be made on stage to solve this problem.

---

**Question 10** (1 mark)

The following excerpt is in two parts.

What type of effect has been added to the vocal part?

---

**SECTION B****Question 1** (3 marks)

Tick (✓) the correct box.

What type of microphone would you be most likely to use in the following situations?

- Filming on location
  - ribbon microphone
  - shotgun microphone
  - cardioid microphone
  - omnidirectional microphone
  
- Recording vocals in a studio
  - headset microphone
  - shotgun microphone
  - dynamic microphone
  - condenser microphone
  
- Miking an acoustic bass, with no amplifier, at a live gig
  - crystal microphone
  - carbon microphone
  - cardioid microphone
  - omnidirectional microphone

**Question 2** (7 marks)

On the diagram on page 7, indicate the position of each of the following items by writing the corresponding letter (**A.–G.**) in the correct box. Not all boxes will be used.

- A.** the in/out socket for connecting signal processing devices
- B.** the knob used for setting input level for channel input
- C.** the faders that would control the output level at a live gig
- D.** the knob used to send a channel signal to an external reverb unit
- E.** the switch used to check the channel input level both on headphones and via meter
- F.** the switch used to select the bass frequency roll off for a vocal microphone
- G.** the switch used to assign a channel to a group

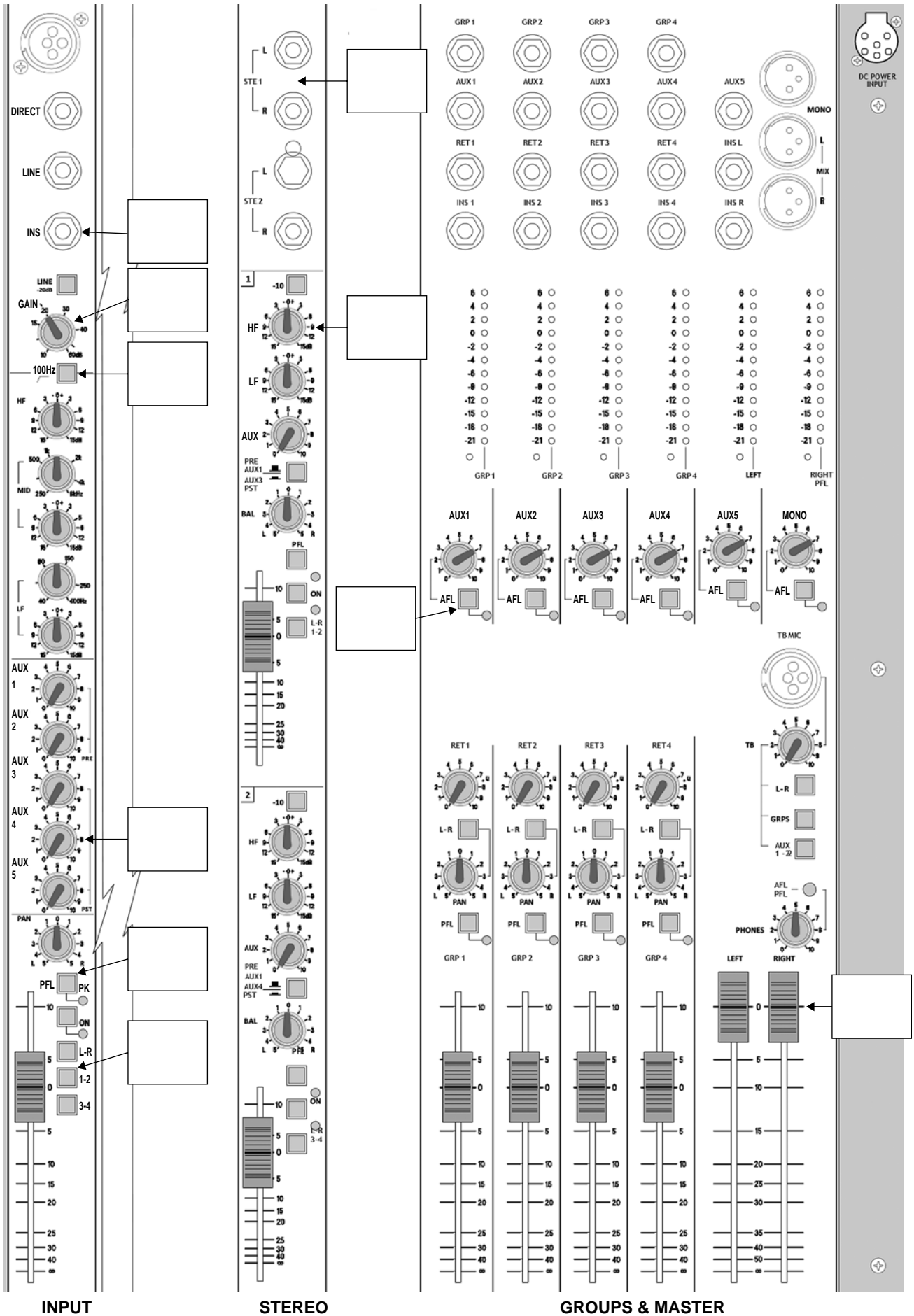

**Question 3** (5 marks)

- a. Suggest **two** possible reasons for an audio earth hum. 2 marks

---

---

- b. Why is it important for an electrical cable to have a good earth? 1 mark

---

- c. Why is it important for an audio cable to be earthed or balanced for long cable runs? 1 mark

---

- d. What is the main difference between a speaker lead and a microphone lead? 1 mark

---

**Question 4** (2 marks)

- a. What piece of equipment should be provided to a musician doing an overdub? 1 mark

---

- b. Why is this equipment needed? 1 mark

---

**Question 5** (3 marks)

- a. What is a 'shock mount'? 1 mark

---

- b. In what common situation might a shock mount be used and why? 2 marks

---

---



**Question 6** (4 marks)

Pat arrives to set up for a speech and finds the PA wrongly patched, as shown below.

microphone → graphic equaliser → amplifier → mixing console → active speaker

- a.** Identify the problems with the setup. 3 marks

---



---



---

- b.** List the correct setup. 1 mark

---



---

**Question 7** (3 marks)

- a.** Describe the technique of close miking. 1 mark

---

- b.** Give **two** reasons for the use of close miking when recording several instruments at once in the same space. 2 marks

---



---

**Question 8** (4 marks)

There are concerns about the occupational health and safety (OH&S) of staff and crew working in a venue and mixing a gig that is very loud.

- a.** What is the name of the condition that can occur after prolonged periods of exposure to loud noise? 1 mark

---

- b.** Name **three** things that could be done to reduce the risk of hearing damage. 3 marks

---



---



---

**Question 9** (3 marks)

Name the microphone polar patterns shown below.

1.

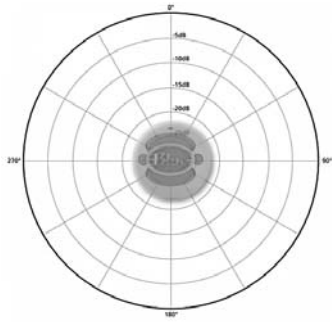

---

2.

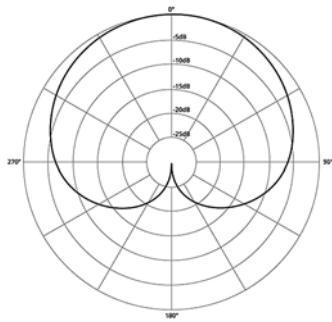

---

3.

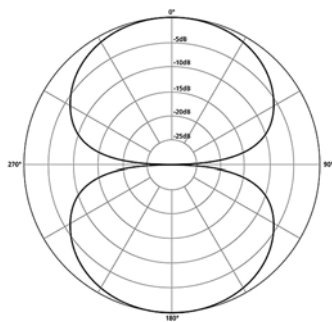

---

Sources: (1.) [www.voiceactingmastery.com](http://www.voiceactingmastery.com); (2.) and (3.) [www.harmonycentral.com](http://www.harmonycentral.com)

**Question 10** (2 marks)

a. What is a cut or pad switch used for?

1 mark

---

b. What kind of filter would typically be used to remove low-frequency rumble?

1 mark

---

**Question 11** (3 marks)

What **three** file attributes are required when mastering a broadcast-quality recording for manufacturing an audio CD?

---

---

---

**Question 12** (2 marks)

List **two** problems that may occur if power for audio equipment was sourced from a dimmer rack.

---

---

**Question 13** (4 marks)

Describe a four-step method for tuning a PA system in order to effectively reduce feedback using a microphone and a graphic equaliser.

1. \_\_\_\_\_

2. \_\_\_\_\_

3. \_\_\_\_\_

4. \_\_\_\_\_

**Question 14** (6 marks)

a. Why is a stage plan useful when setting up a gig?

2 marks

---

---

b. Several bands are to play at a music festival. The FOH mixer is provided with two documents: a running sheet and a stage plan for each act.

Provide two examples of information included on each of these documents.

4 marks

Document	Information
running sheet	<ul style="list-style-type: none"><li>• _____</li><li>• _____</li></ul>
stage plan	<ul style="list-style-type: none"><li>• _____</li><li>• _____</li></ul>

**Question 15** (7 marks)

a. What is meant by ‘demo recording’ and how is a demo recording used? 2 marks

---



---

b. Suggest a demo recording plan for a rock band with the following instrumentation and equipment. The aim is to be able to **maximise control** over the individual sounds when mixing the song after recording has been completed.

Your plan should include:

- the sequence of instruments to be recorded
- which equipment will be used for each track
- a list of what will be recorded on each track.

5 marks

<b>Instruments</b>	<b>Equipment</b>
electric keyboard (stereo outputs)	digital audio workstation (DAW) with only 4 microphone inputs
2 electric guitars and amplifiers	
drum kit	assortment of microphones, DIs and all associated stands and leads
bass guitar	
vocal	
backing vocal (performed by the same singer)	

---



---



---



---



---



---



---



---



---



---

**Question 16** (6 marks)

Imagine you are recording a three-piece band with vocals, electric guitar, bass guitar and a drum kit. You record all three performers live using an analogue mixing console and a DAW. You discover the following problems when you record the first take:

1. There is too much spill between each of the drum microphones.
2. The bass notes are not at a consistent level and some notes are difficult to hear.
3. The guitar amplifier is emitting a 50 Hz earth hum.

For each of the three problems, suggest:

- a processing device you would use to minimise each problem
- where in the signal chain between the instruments and the DAW you would connect each device.

Problem 1

Processing device \_\_\_\_\_

Where to connect the device \_\_\_\_\_

Problem 2

Processing device \_\_\_\_\_

Where to connect the device \_\_\_\_\_

Problem 3

Processing device \_\_\_\_\_

Where to connect the device \_\_\_\_\_

**Question 17** (4 marks)

Label the two components of this two-way speaker system and the frequency band each component typically reproduces.

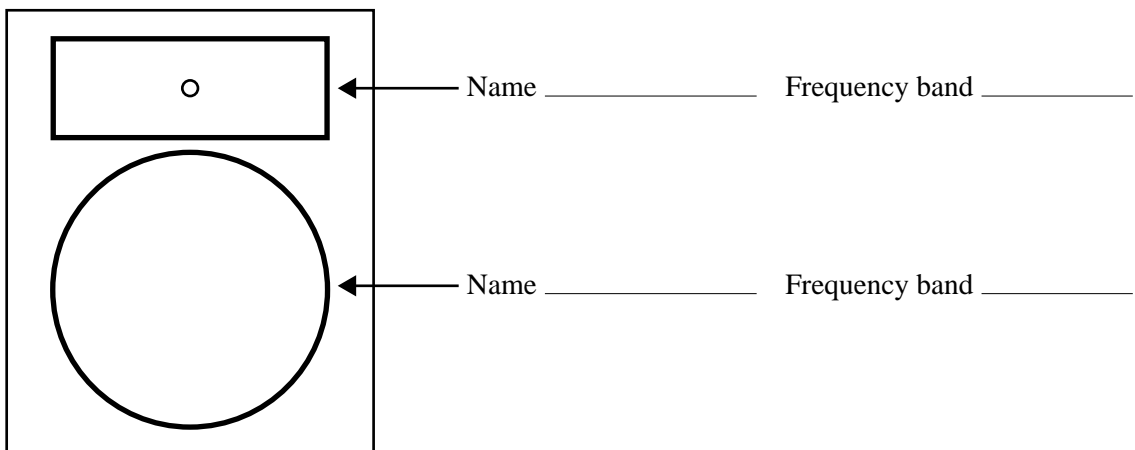

**Question 18** (3 marks)

- a. Describe the effect that a reverb unit emulates. 1 mark

---

- b. What does the pre-delay dial do on a reverb unit? 1 mark

---

- c. What does the feedback dial do on a reverb unit? 1 mark

---

**Question 19** (4 marks)

A range of equipment is installed into a studio rack that is two metres high. The equipment includes power amplifiers, valve compressors and digital effects processors.

Based on the information above, list **two** considerations for each of the following.

- Safe installation \_\_\_\_\_

---

- Efficient operation of the equipment \_\_\_\_\_

---