



# Systems Engineering 2007–2010

## Written examination – November

### Introduction

The VCE Study formerly known as Systems and Technology has been reviewed and the name changed to Systems Engineering. Units 1–4 are being implemented in 2007. The examination criteria and description were published in the *VCE Systems Engineering Assessment Handbook 2006*.

### Examination specifications

#### Overall conditions

The examination will be sat at a time and date to be set annually by the Victorian Curriculum and Assessment Authority.

There will be 15 minutes reading time and 90 minutes writing time.

VCAA examination rules will apply. Details of these rules are published annually in the *VCE and VCAL Administrative Handbook*.

The examination will be marked by a panel appointed by the VCAA.

The examination will contribute 30 per cent to the Study Score.

#### Content

All outcomes of Units 3 and 4 will be assessable. All of the key knowledge and skills that underpin the outcomes are examinable. The examination will assess a representative sample of the key knowledge and skills.

#### Format

There will be two sections in the examination. All questions will be compulsory.

The examination will be in the form of a question and answer book.

**Section A** will consist of 15–20 multiple-choice questions. Each question will be worth 1 mark. Students will be required to mark their responses on a multiple-choice answer sheet.

**Section B** will consist of short-answer questions and will be worth between 60–65 marks. These questions may be stand alone questions, or questions of increasing complexity which relate to a design/engineering scenario. The questions may relate to previously unseen stimulus material. There will not be any questions directly relating to the student's own work or to the work produced for their school-assessed task. However the key knowledge and key skills related to Unit 3 Area of Study 2 and Unit 4 Area of Study 2 are examinable.

#### Approved materials and equipment

A scientific calculator is allowed in this examination.

## Advice

During the 2007–2010 accreditation period for VCE Systems Engineering, examinations will be prepared according to the Examination specifications above. Each examination will be an interpretation of these specifications and will test a representative sample of the key knowledge and key skills.

The following sample questions have been prepared in order to provide an illustration of how this study might be examined, but does not constitute a full examination paper.

## Sample questions

A formula sheet is provided on page 12.

### SECTION A – Multiple-choice questions

#### Question 1

How much force is required to accelerate a 200 gram mass at  $2 \text{ m/s}^2$ ?

- A. 400 N
- B. 800 N
- C. 100 N
- D. 0.4 N

#### Question 2

In the figure below there are two gears, A and B.

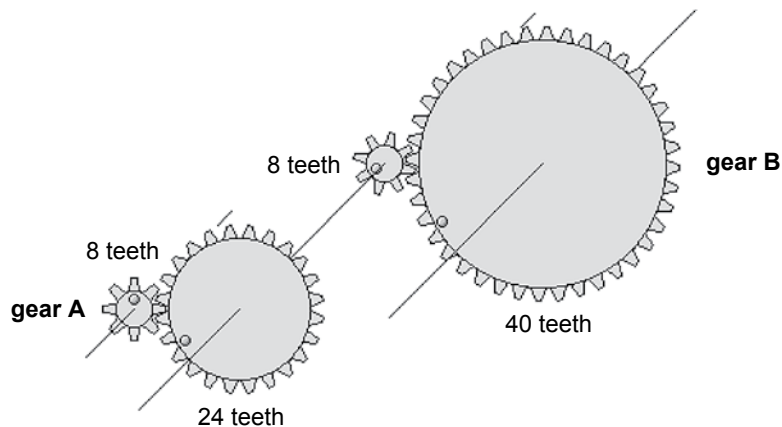

If gear A rotates at 60 rpm, gear B will rotate at

- A. 2 rpm
- B. 4 rpm
- C. 30 rpm
- D. 900 rpm

**Question 3**

The figure below shows two joined cylinders.

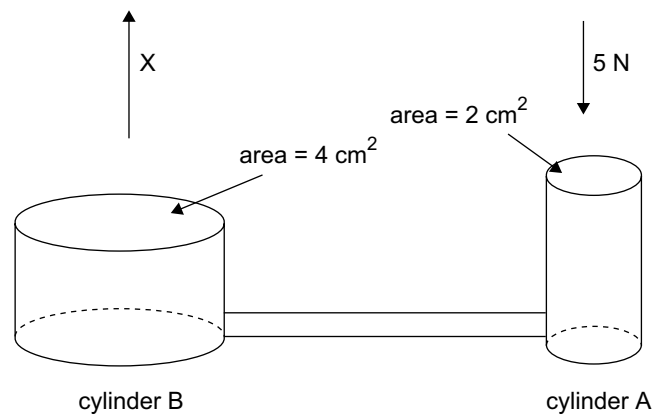

If a 5 newton force is applied down on cylinder A, what is the force up on cylinder B?

- A.  $16 \pi \text{N}$
- B. 10 N
- C.  $8 \pi \text{N}$
- D. 2.5 N

**Question 4**

The figure below shows, a 6 kg mass balancing at one end of a beam.

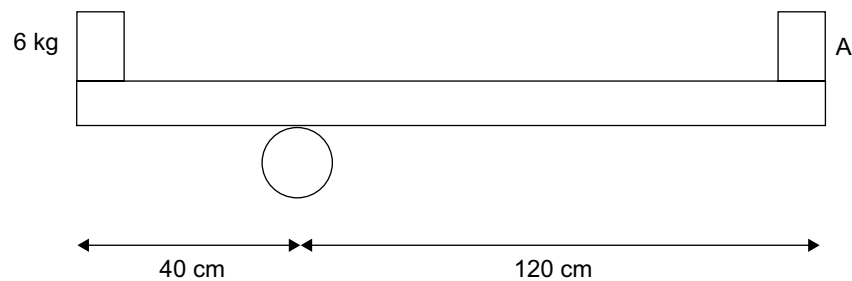

What is the mass at point A needed to balance the 6 kg mass?

- A. 2 kg
- B. 3 kg
- C. 6 kg
- D. 19.6 kg

**Question 5**

The design of a system should **not** take into account the following

- A. the diagram or plans of the system
- B. the disposal of the system
- C. how easy it is to change parts that are subject to wear
- D. the teacher in charge of your class

**Question 6**

The symbol for a voltage regulator is

A.

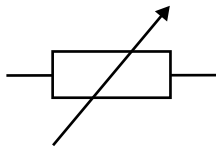

B.

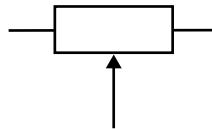

C.

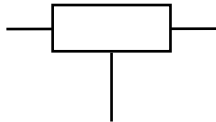

D.

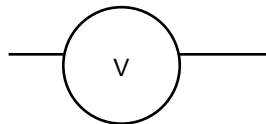
**Question 7**

The current passing through the battery in the circuit in the figure below is

- A. 120 A
- B. 8.6 A
- C. 120 mA
- D. 16.7 mA

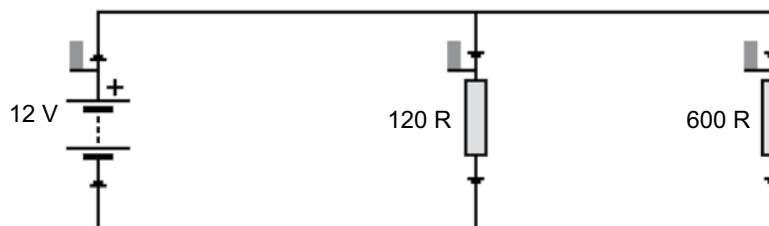
**Question 8**

The main purpose of a transformer is

- A. to rectify voltage.
- B. to convert AC to DC.
- C. to step up or step down AC voltage.
- D. to transfer energy from one form to another.

**Question 9**

What is the reading on the multimeter below?

- A. 29.7 mA
- B. 29.7 V
- C. 29.7  $\Omega$
- D. 0.0297 V

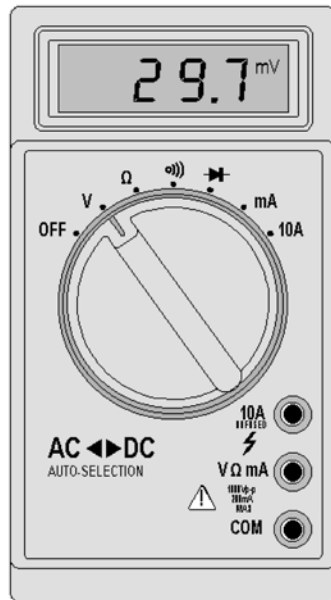
**Question 10**

Which of the following is **not** a bio-fuel?

- A. a fuel derived from vegetable oil
- B. electricity made from solar power
- C. ethanol made from sugar cane
- D. diesel made from canola oil

**Question 11**

What value is the resistor shown below?

- A. 15  $\Omega$
- B. 150  $\Omega$
- C. 154 K $\Omega$
- D. 154 R

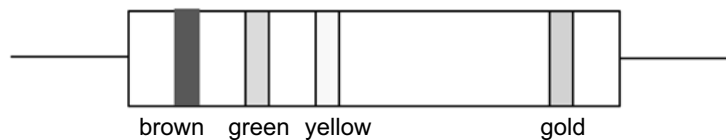

## SECTION B – Short answer questions

Figure 1a below shows a circuit board and Figure 1b shows a circuit board layout.

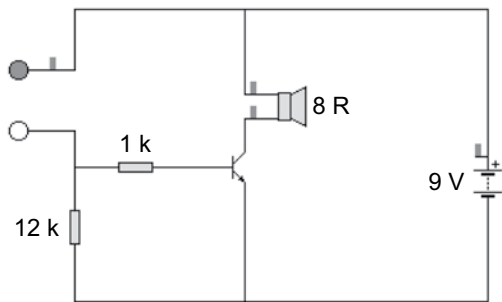

Figure 1a

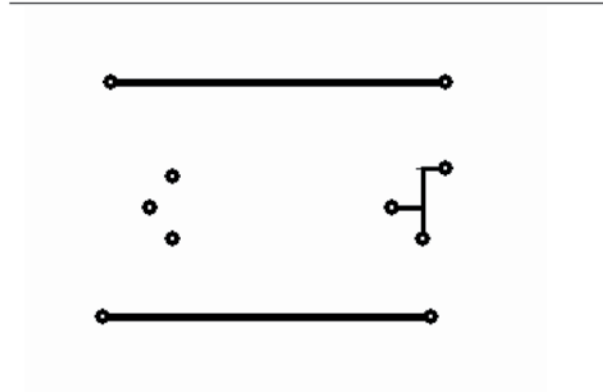

Figure 1b

### Question 1

Complete the circuit board layout above by adding four missing tracks and two pads.

3 marks

### Question 2

In the space below, sketch a compound gear to reduce a motor turning at 1200 rpm to a shaft turning at 3 rpm. (The maximum number of teeth on these gears is 200, the minimum is 8.)

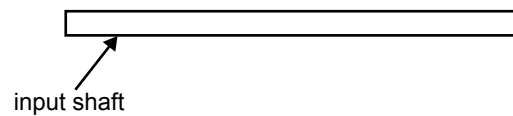
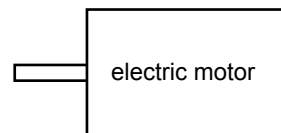

4 marks

**Question 3**

a. Name the most abundant greenhouse gas.

---

b. What does the term 'greenhouse' mean in terms of the environment?

---



---

c. Explain how the greenhouse effect works in terms of the gas you mentioned in **part a.** above.

---

d. Power stations are a source of energy that produce a large amount of greenhouse gasses. An alternative source of energy is a hydrogen fuel cell.

Using the diagram below, describe how a hydrogen fuel cell works. Include the input and output on the diagram, and describe below how the electric charge is produced.

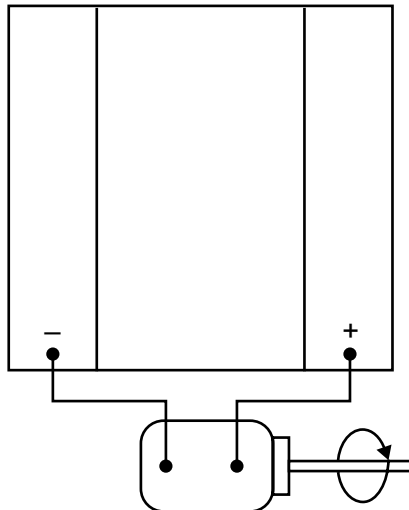

---



---



---



---



---

1 + 2 + 2 + 4 = 9 marks

**Question 4**

- a. Give a possible electrical subsystem, electromechanical subsystem and a possible mechanical subsystem for a showground merry-go-round.

electrical subsystem \_\_\_\_\_

electromechanical subsystem \_\_\_\_\_

mechanical subsystem \_\_\_\_\_

- b. Name an input to the merry-go-round.

\_\_\_\_\_

- c. Name an output to the merry-go-round.

\_\_\_\_\_

- d. Explain whether a feedback loop is likely to be part of the merry-go-round.

\_\_\_\_\_

\_\_\_\_\_

\_\_\_\_\_

3 + 1 + 1 + 2 = 7 marks

**Question 5**

On the pulley in Figure 2 below, calculate the force necessary to keep the 30 N force in equilibrium. Show all working.

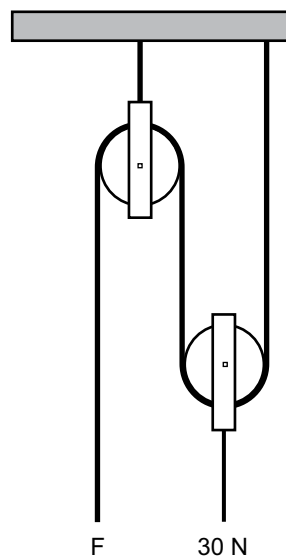

**Figure 2**

2 marks

Figure 3a below shows a model crane. Figure 3b shows the circuit diagram of the motor for the crane. Use these figures to answer questions 6–12.

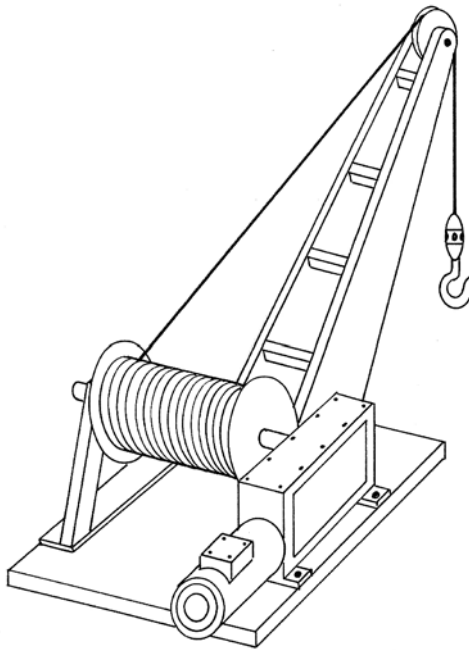

**Figure 3a** Model crane

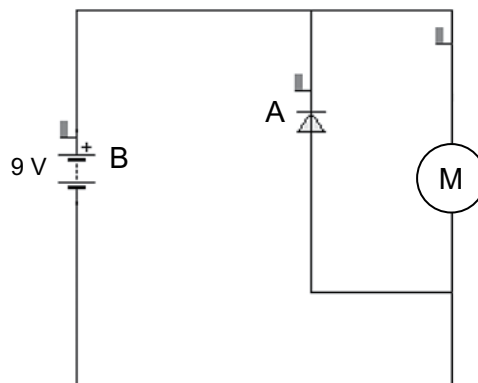

**Figure 3b** Circuit diagram for the motor of the model crane

**Question 6**

Name the components A and B on the circuit diagram.

A \_\_\_\_\_

B \_\_\_\_\_

2 marks

**Question 7**

The specifications of the model crane motor are given below.

voltage range	3 – 12V DC
speed (no load)	3600 rpm
current (no load)	0.07 A
torque @ max efficiency	3.07 g/cm

If a 6 V battery is used to power the motor, what will the power output be under no load?

Show all working.

2 marks

**Question 8**

On the diagram below (copy of Figure 3b), sketch where you would place an ammeter in order to find the current through the motor under load.

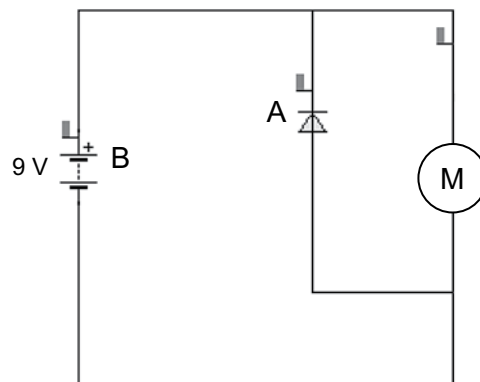

2 marks

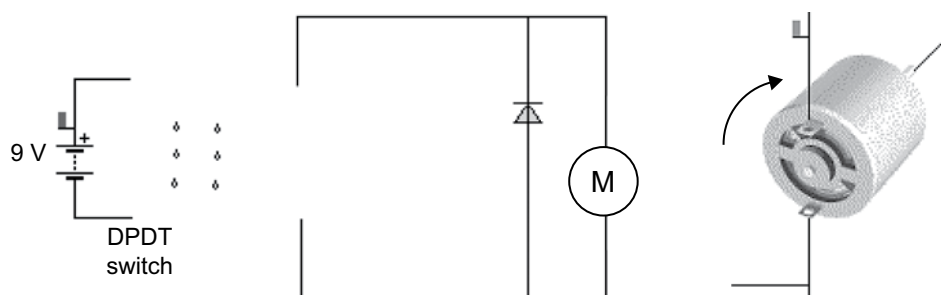
**Question 9**

**Figure 4**

A Double Pole Double Throw Switch (DPDT) is used to reverse the direction of rotation of the motor shaft. Complete the wiring diagram (Figure 3).

3 marks

**Question 10**

Figure 4 shows part of a winch system. Sketch and label on Figure 4 a gearing system that would reduce the rotational speed of the motor to the shaft by 80:1.

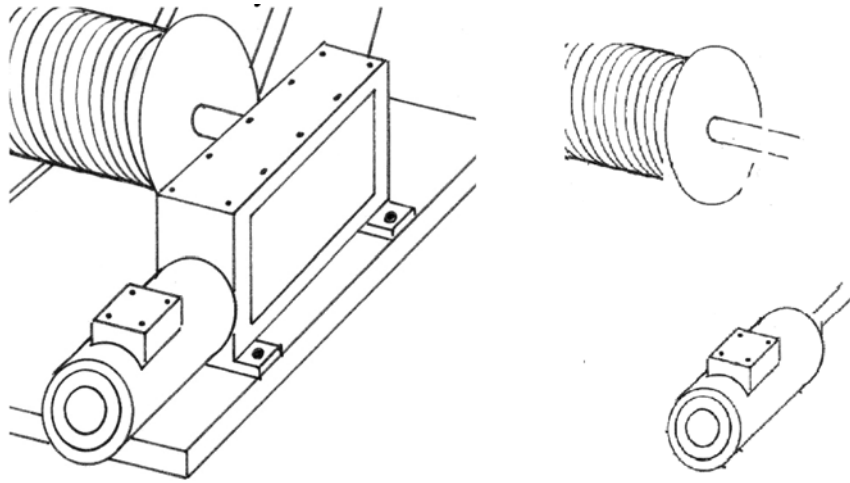

**Figure 4**

4 marks

**Question 11**

If the radius of the spool is 0.3 m, what is the circumference of the spool?  
Show all working.

2 marks

**Question 12**

If the spool rotates once every 5 seconds, at what speed is the winch wire hauled in?  
Show all working.

1 mark

## Formula sheet

Work done = force  $\times$  distance moved

Gear ratio =  $\frac{\text{number of teeth driver gear}}{\text{number of teeth driven gear}}$

Gear ratio final = gear ratio 1  $\times$  gear ratio 2

Efficiency =  $\frac{\text{output energy}}{\text{input energy}} \times 100\%$

Voltage = current  $\times$  resistance

Resistance in parallel =  $\frac{R_1 \times R_2}{R_1 + R_2}$

Resistance in series =  $R_1 + R_2$

Colour codes

Colour	Value
black	0
brown	1
red	2
orange	3
yellow	4
green	5
blue	6
violet	7
grey	8
white	9
gold	5%
silver	10%

Moment = force  $\times$  distance

Velocity =  $\frac{\text{displacement}}{\text{time}}$

$P = V \times I$

$Q = C \times V$

$V = I \times R$

Frequency =  $\frac{1}{\text{period}}$

$\frac{\text{force}_a}{\text{force}_b} = \frac{\text{cross sectional area}_a}{\text{cross sectional area}_b}$