



2006 Systems and Technology GA 3: Written examination

GENERAL COMMENTS

The 2006 Systems and Technology examination was based on all areas of study of Units 3 and 4 of the *Systems and Technology VCE Study Design*. In setting the examination, the panel used the outcomes for Units 3 and 4 and the following criteria:

- knowledge of technological concepts and principles associated with integrated systems
- knowledge of technological concepts and principles associated with the control of integrated systems
- understanding of the function of, and interrelationships between, a system and its subsystems
- understanding of the relationship between technological systems and the natural environment
- understanding of the concepts of diagnosis, evaluation, adjustment and repair
- understanding of the role of design in the production of a technological system.

Students were required to answer all questions on the paper.

Following are comments about each question and how marks were assigned. In the case of descriptive answers, sample answers have been supplied. This report should be read in conjunction with the 2006 Systems and Technology examination paper.

SPECIFIC INFORMATION

Note: A high-scoring student’s responses are given as examples of appropriate answers. Responses reproduced herein have not been corrected for grammar, spelling or factual information.

Question 1

Question 1 required students to demonstrate an understanding of their production work. This included the ability to comment on design and/or modification work to the system, describing its input, process and output and energy conversion. Students were also required to answer questions regarding the impact their system would have on the environment.

Students were first asked to name the system they had constructed. Subsequent answers to all parts of Question 1 needed to relate to this system.

A high-scoring student’s responses to Question 1 are given below. The integrated system named by the student was a soccer table with an automatic ball return. The design/modification was to install infrared sensors and an airblower and pipe system.

1a–b.

Marks	0	1	2	3	4	Average
%	6	8	26	20	40	2.8

1a.

After naming the integrated system constructed, students had to explain two features of the system that allowed it to be categorised as an integrated system. An integrated system is a system comprising both electrical/electronic and mechanical subsystems.

It has an infrared subsystem which is electronic and an Air Blower which is a mechanical/pneumatic system.

1b.

Students had to name the design or modification work carried out on their system and its purpose.

The infrared sensors detect when a goal has been scored. This is processed by a microcontroller which activates the blower. The purpose of the system is to shoot the ball back up onto the playfield.

1c.

Marks	0	1	2	3	4	5	6	Average
%	5	6	12	17	23	18	20	3.8



1ci.

For three marks, students were required to describe specific values that apply to the system's input, process and output. Answers with some detail were awarded two marks. Brief or basic answers that related to the system but did not mention values or specific terms were awarded one mark.

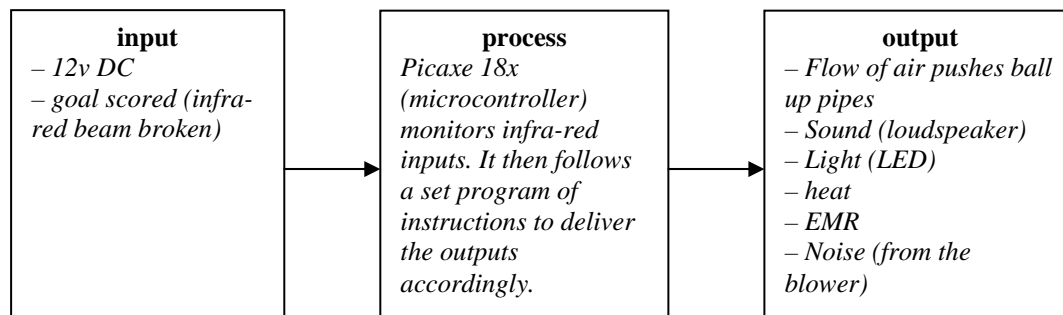

1cii.

Students' answers had to relate to the process of energy conversion taking place in the system already named. They could either describe/draw/label or employ a combination of all three methods. Three marks were awarded for accurate, comprehensive summaries with excellent use of specific terms where appropriate; answers that had some detail and mentioned specific terms were awarded two marks; basic answers with little detail but which clearly related to the system received one mark.

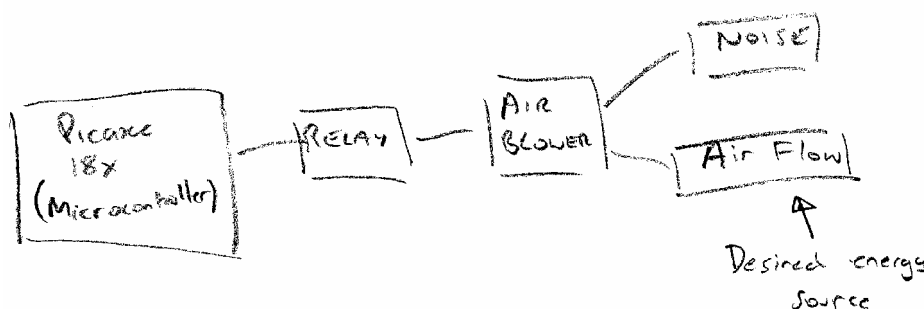

The Picaxe 18x Microcontroller sends out a signal, which is amplified by a transistor, which activates the relay. Electrical energy now flows into the motor, creating mechanical energy. This creates rotary motion in the fan which pushes a steady flow of air out the blower nozzle. This is used to push the ball up the pipes.

1d.

Marks	0	1	Average
%	23	77	0.8

Students' answers had to relate to a negative impact created by the system already named.

The generation of the sealed lead-acid battery used would require land to be cleared for the resources. Poor disposal of it could also be harmful.

1e.

Marks	0	1	2	3	4	5	Average
%	14	10	22	26	17	10	2.5

To be awarded five marks, answers needed to be comprehensive, state both advantages and disadvantages, formulate a clear discussion using appropriate specific terminology and lead to a conclusion.

Less detailed answers that were still comprehensive were awarded two to four marks depending upon the response, while very brief answers that related to the question were awarded one mark

The mining of resources and improper disposal of the sealed-lead acid battery used would have a negative effect on the environment. Another disadvantage is the noise emitted by the Air Blower, however, this will cause no long-lasting damage as it is well within safe standards (the decibel rating) and is little more than annoying. A positive impact of the system is that it provides entertainment to people and may make their day happier. I believe that this is more important than the negative effects as the effect they have on the natural environment is fairly minor.

2006 Assessment Report



Question 2

Question 2 dealt with the mechanical aspects and measurement of the movement subsystem.

2a-d.

Marks	0	1	2	3	4	5	Average
%	9	7	14	21	24	25	3.2

2a.

Students were required to state the type of motion of their system, using the correct terms of linear, rotary, oscillating and reciprocal.

Linear Motion (of the ball/air in the pipes)

2b.

Students needed to give a relevant use of the movement described in Question 2a.

To push the ball back up to the playfield.

2c.

For two marks students had to provide two testable, measurable performance criteria that matched the type of movement of their named system.

- How long the ball takes to get back up?
- How reliable is it? Does it work every single time?

2d.

The item of test equipment that students named here needed to be relevant to the movement being measured and capable of measuring in a scientific unit.

Stopwatch

2e.

Marks	0	1	2	3	Average
%	38	21	21	20	1.2

Students needed to give a comprehensive summary of how the named item of test equipment was set up and then used to test the output motion. Assessors looked for good use of technical language, specific measurement and mention of scientific units. Less comprehensive descriptions that used technical language and scientific units of measurement were awarded two marks.

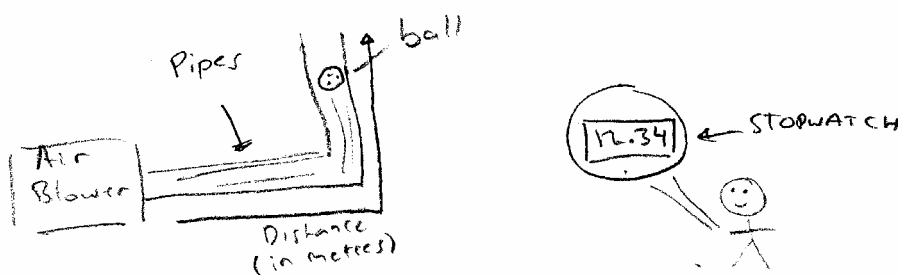

You would time how long the ball takes to get back to the top using the stopwatch. Results will be in seconds. You could also use a metric measuring tape to find out how far it travelled in metres, giving you an average speed in ms^{-1} .

2f.

Marks	0	1	Average
%	25	75	0.8

The answer here should have been a principle that related to the operation of the named subsystem.

Pneumatic – the main component is air.

2006 Assessment Report



Question 3

3a–b.

Marks	0	1	2	3	Average
%	18	16	19	47	2.0

3a.

The voltage stated here needed to be AC or DC **and** needed to relate to the justification given in part b.

3b.

To be awarded two marks students' answers needed to clearly state a scientifically sound justification for their response of AC or DC in part a. Answers which were correct but which were generic and non-scientific only received one mark.

3c.

Marks	0	1	2	Average
%	21	24	55	1.4

3ci.

Student answers had to clearly state a voltage value that can be measured and which related to the named system.

3cii.

Student answers needed to clearly state a reason that justified the suitability of the voltage to meet subsystem performance criteria.

3d.

Marks	0	1	Average
%	13	87	0.9

The item of test equipment that students named here needed to be capable of measuring the voltage and measuring in a scientific unit.

3e.

Marks	0	1	2	3	Average
%	24	35	28	13	1.3

Students should have provided a comprehensive summary of how the named item of test equipment was set up and then used to measure the voltage. Assessors looked for good use of technical language, specific measurement and mention of scientific units. Two marks were given to less comprehensive descriptions that used technical language and scientific units of measurement. One mark was awarded to any basic description that at least related to the question.

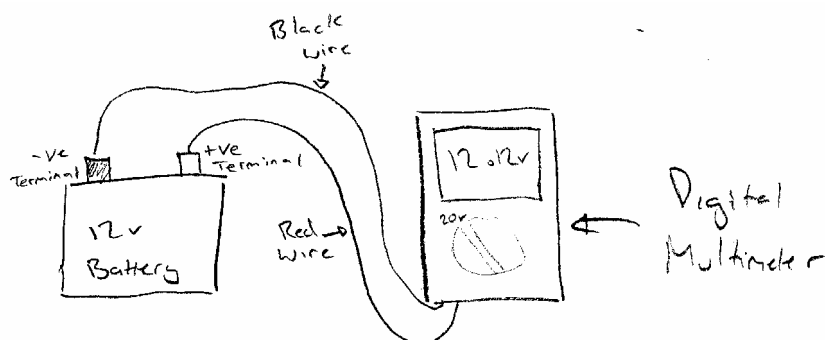

Connect the red probe from the digital multimeter to the +Ve Terminal of the battery and the black probe to the -Ve terminal. Change the multimeter setting to 20VDC (as this is expected result range) and the multimeter will measure the potential difference. The reading will be in volts.

Question 4

4a.

Marks	0	1	2	3	Average
%	3	16	45	36	2.2

Students were required to describe the operation of the merry-go-round in terms of its input, process and output.

2006 Assessment Report

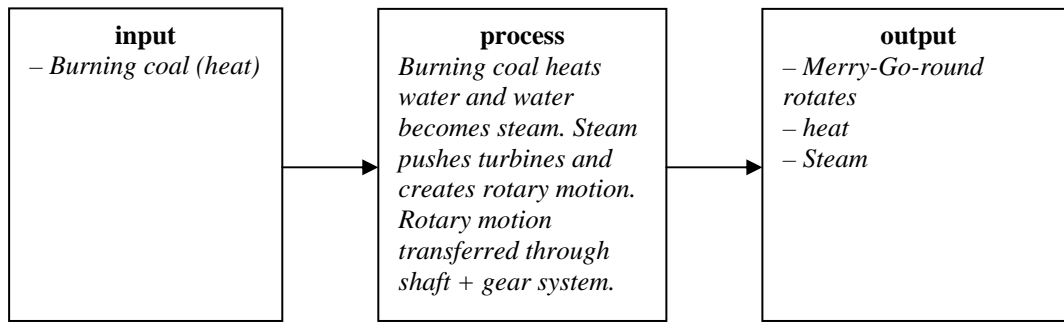

4b.

Marks	0	1	2	3	4	Average
%	41	6	14	12	26	1.8

bi.

Students were asked to redraw the pulley drive system shown in the figure and include a mechanism to engage or disengage the pulleys.

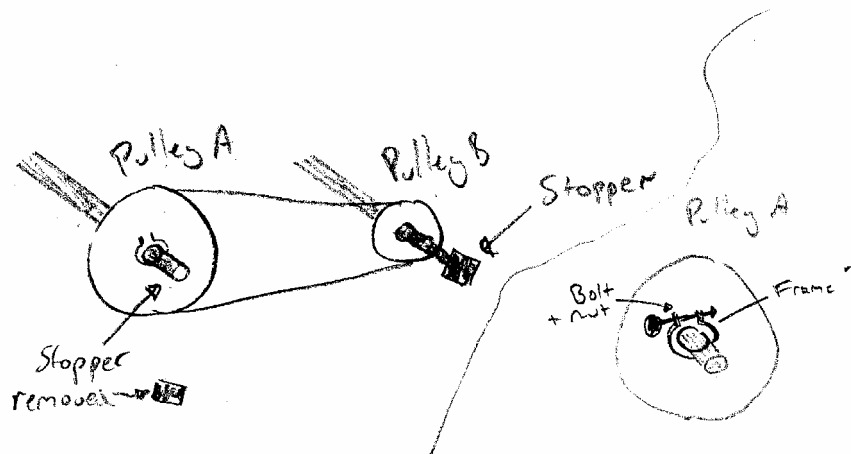

bii.

Students then had to explain how the design operates. A clear explanation that related to the diagram gained two marks.

To disengage the pulleys, take both the stoppers out and simply slide the pulleys off the axle. To engage slide the pulleys back on and put the stoppers on so they don't fall off. A bolt and nut can be screwed onto a frame near the axle to maintain pressure.

4c.

Marks	0	1	Average
%	37	63	0.6

Students were required to show how the merry-go-round could go in the reverse direction.

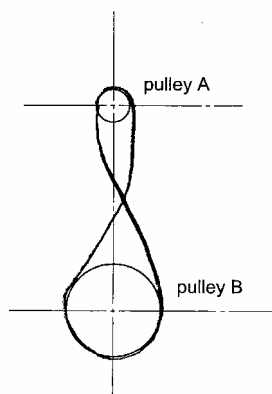

2006 Assessment Report



4d.

Marks	0	1	2	Average
%	31	16	53	1.2

Students were asked to calculate the diameter of pulley B.

$$\frac{\text{Diameter Pulley B}}{\text{Diameter Pulley A}} = \frac{\text{RPM Pulley A}}{\text{RPM Pulley B}}$$

$$\frac{x}{12} = \frac{12}{3}$$

$$x = 4 \times 12$$

$$x = 48$$

Diameter of pulley B = 48cm

4e.

Marks	0	1	2	3	Average
%	19	16	26	40	1.9

ei.

Students were required to add a gear system that would enable shaft A to drive shaft B.

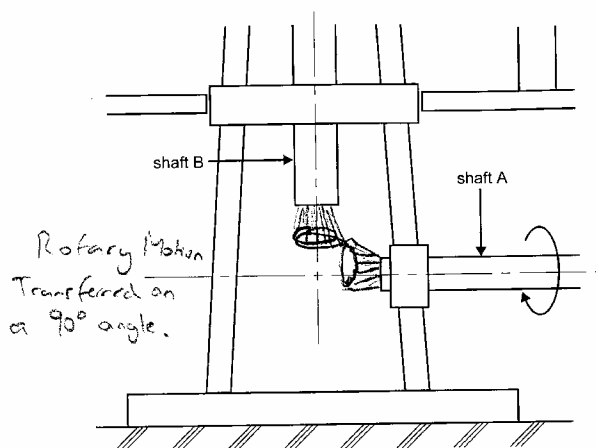

Figure 3

yii.

Students had to name the type of gears drawn.

Bevel gears

4f.

Marks	0	1	Average
%	6	94	1.0

Students were asked to nominate the direction shaft C would rotate.

Clockwise from top view.

4g.

Marks	0	1	2	3	Average
%	17	23	31	29	1.7

Students were required to label the effort, fulcrum and load acting in shaft C.

2006 Assessment Report

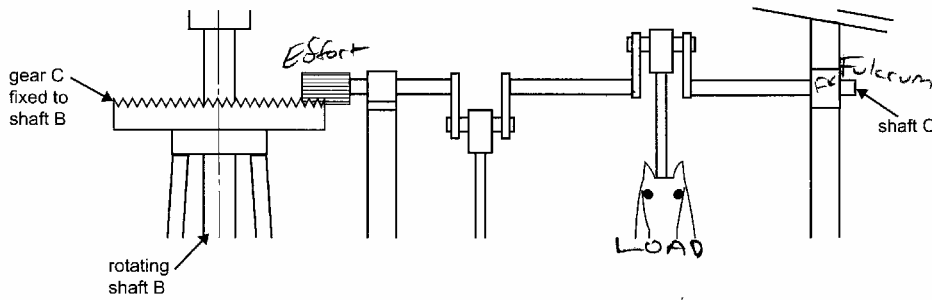

4h.

Marks	0	1	Average
%	38	62	0.6

Students were required to calculate the gear ratio of gear C and gear D.

$$\begin{aligned}
 \text{Gear ratio} &= \frac{\text{teeth on driver}}{\text{teeth on driven}} \\
 &= \frac{60}{12} \\
 &= 5 \\
 &= 5:1
 \end{aligned}$$

4i.

Marks	0	1	2	3	Average
%	43	27	19	12	1.0

Students were required to design a gear system to give a ratio of 400:1.

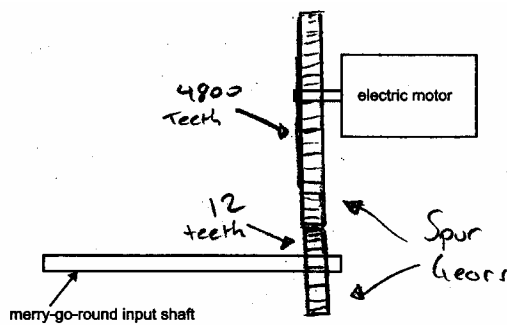

$$\begin{aligned}
 \text{Driver} &= 4800 \\
 \text{Driven} &= 12
 \end{aligned}$$

$$\begin{aligned}
 \text{Gear ratio} &= \frac{4800}{12} \\
 &= 400
 \end{aligned}$$

Question 5

5a-b.

Marks	0	1	2	3	Average
%	63	22	7	8	0.6

Students were required to draw two additional connections on the relay to reverse the DC motor when the button is pushed, and a standard diode symbol, connected in reverse bias to the supply.

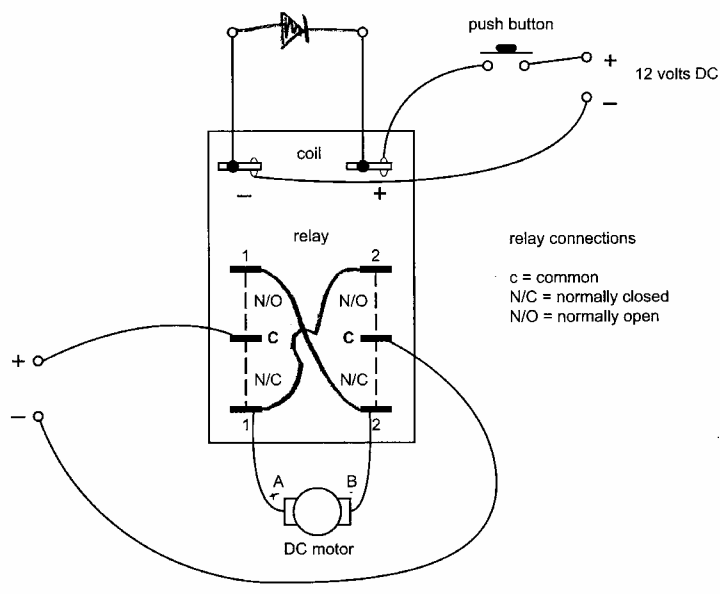

diagram not to scale

Figure 7

5c.

Marks	0	1	2	3	4	5	6	Average
%	9	10	11	11	13	17	29	3.7

Students were required to name the components shown in Figure 8.

Letter	Components
(A)	10K resistor
(B)	0.1µF capacitor
(C)	555 Timer (IC chip)
(D)	Diode
(E)	110K Variable resistor
(F)	NPN Transistor

5d.

Marks	0	1	Average
%	37	63	0.7

Students had to nominate the connection configuration of the resistors across pins 6 and 7.

Parallel

5e-f.

Marks	0	1	2	3	4	Average
%	28	16	19	22	15	1.8

5e.

Students had to calculate the resistance across pins 6 and 7. They were assessed on use of formula, working and provision of the correct answer.

2006 Assessment Report



$$R_t = \frac{R_1 \times R_2}{R_1 + R_2}$$

$$= \frac{10 \times 12}{10 + 12}$$

$$= 5.45K$$

$$= 5455\Omega$$

5f.

Students were asked to provide the voltage present on pin 1 of the LM555.

0 volts

5g-h.

Marks	0	1	2	3	4	5	6	Average
%	32	8	11	11	11	5	21	2.6

5g.

Students were required to calculate the maximum power used by the motor. They were marked on their use of formula, working and providing a correct answer (including correct units).

$$700 \text{ mA} = 0.7A$$

$$P = VI$$

$$= 10.2 \times 0.7$$

$$= 7.14 \text{ watts}$$

5h.

Students were required to calculate the efficiency of the speed controlling unit. Students were marked on the use of formula, working and providing a correct answer.

$$\text{Input power} = V \times I$$

$$= 12 \times 1$$

$$= 12 \text{ watts}$$

$$\text{Output power} = V \times I$$

$$= 10.2 \times 0.7$$

$$= 7.14 \text{ watts}$$

$$\text{Efficiency} = \frac{\text{output power}}{\text{input power}} \times \frac{100}{1}$$

$$= \frac{7.14}{12} \times 100$$

$$= 59.5\%$$

6a-b.

Marks	0	1	2	Average
%	34	16	49	1.2

6a.

Students were required to name an item of equipment used to test if the merry-go-round spins at 3 rpm.

Stopwatch

6b.

Students needed to give the name of the scientific units that are measured with this item of test equipment.

Minutes (or seconds)

6c.

Marks	0	1	2	3	Average
%	39	13	19	28	1.4



Students were required to describe, draw and label how they would conduct the test.

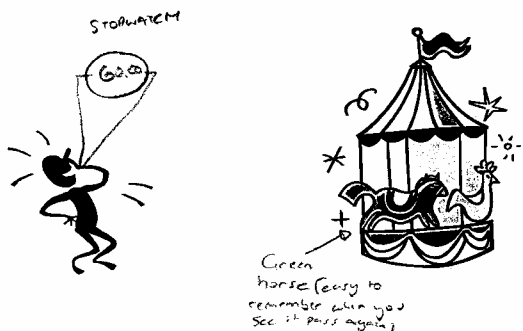

Figure 10

Choose a horse/animal different to the rest. When it is closest to you start the stopwatch. Record how many times you see it pass in one minute. This is how many revolutions it has made (RPM).

6d.

Marks	0	1	Average
%	47	53	0.5

Students had to name a factor that could contribute to efficiency loss in the operation of the merry-go-round.

Friction

6e.

Marks	0	1	2	Average
%	48	19	33	0.9

Students had to describe how this factor contributes to efficiency loss. Students gained two marks for a clear answer and technical description.

Because energy is being lost and being converted to heat. This means less of the input power is working towards the desired outcome.

6f.

Marks	0	1	Average
%	58	42	0.4

Students had to state how efficiency loss could be reduced.

By using a lubricant.

6g.

Marks	0	1	2	3	Average
%	44	17	17	22	1.2

Students were required to draw a voltmeter and an ammeter. Connections and labelling were required.

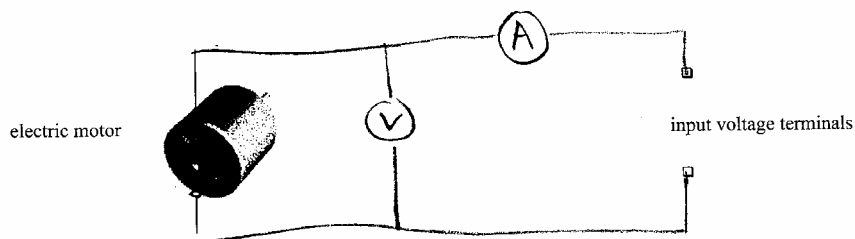

Ⓐ = Ammeter
Ⓥ = Voltmeter

2006 Assessment Report



Question 7

7a.

Marks	0	1	2	Average
%	55	34	12	0.6

Students were required to discuss the environmental advantages and disadvantages of burning coal at the site of the merry-go-round.

The burning of coal releases carbon emissions but an advantage of this is they can generate the power whenever they need to.

7b.

Marks	0	1	2	Average
%	55	33	12	0.6

Students were required to discuss the environmental advantages and disadvantages of the merry-go-round receiving power from a distant coal-fired station.

The resources used would require the clearing of land to be mined and generation releases carbon emissions. It is however fairly cheap and reliable.