



**Victorian Certificate of Education  
2003**

SUPERVISOR TO ATTACH PROCESSING LABEL HERE

**STUDENT NUMBER**

Figures  
Words

Letter

--

**SYSTEMS AND TECHNOLOGY**  
**Written examination**

**Wednesday 19 November 2003**

**Reading time: 2.00 pm to 2.15 pm (15 minutes)**

**Writing time: 2.15 pm to 3.45 pm (1 hour 30 minutes)**

**QUESTION AND ANSWER BOOK**

**Structure of book**

<i>Number of questions</i>	<i>Number of questions to be answered</i>	<i>Number of marks</i>
11	11	95

- Students are permitted to bring into the examination room: pens, pencils, highlighters, erasers, sharpeners, rulers, an approved graphics calculator (memory cleared) and/or one scientific calculator.
  - Students are NOT permitted to bring into the examination room: blank sheets of paper and/or white out liquid/tape.
- Materials supplied**
- Question and answer book of 20 pages including formulas on page 20.
- Instructions**
- Write your **student number** in the space provided above on this page.
  - All calculations must show appropriate formulas and working.
  - All written responses must be in English.

**Students are NOT permitted to bring mobile phones and/or any other electronic communication devices into the examination room.**

**Instructions**

Answer **all** questions in the spaces provided.

**Question 1**

As part of your course you were required to construct an integrated system with a control device.

Name the integrated system you produced.

\_\_\_\_\_

a. Define the term integrated system.

\_\_\_\_\_

\_\_\_\_\_

1 mark

b. Explain the purpose of your integrated system.

\_\_\_\_\_

\_\_\_\_\_

\_\_\_\_\_

2 marks

Your integrated system was constructed using subsystems.

c. Name the two subsystems that made your system an integrated system.

Subsystem 1 \_\_\_\_\_

Subsystem 2 \_\_\_\_\_

2 marks

- d. Draw a systems block diagram which describes in terms of input, process and output, the operation of each of the subsystems you named in part c.

Subsystem 1

Subsystem 2

6 marks

- e. Name a device that controlled your integrated system.

---

1 mark

- f. Explain how this device operated to control your system.

---

---

---

2 marks

In producing your integrated system you were required to carry out design or modification work.

**g.** Name the design or modification work that you carried out.

---

1 mark

**h.** Explain the intended purpose of the design or modification work.

---

---

2 marks

**i.** Describe an important factor that you took into consideration when carrying out your design or modification work.

---

---

---

2 marks

Total 19 marks

**Question 2**

As part of your course you were required to carry out a diagnostic test.

Name the integrated system on which you conducted a diagnostic or fault-finding test.

- 
- a.** Name the specific test that you carried out.
- 
- 
- 1 mark
- b.** Explain in detail the purpose of the test.
- 
- 
- 
- 
- 2 marks
- c.**
- i.** Name one piece of test equipment that you used to take measurements on this system.
- 
- ii.** Describe the function of this piece of test equipment.
- 
- 
- iii.** Name the specific unit of measurement read from the test equipment that you named in part **c.i.**
- 
- 1 + 1 + 1 = 3 marks
- d.** Describe an appropriate adjustment, repair or maintenance procedure that was carried out as a result of your test.
- 
- 
- 
- 2 marks
- Total 8 marks

**TURN OVER**

**Question 3**

As part of your course you studied how a technological system interacts with the natural environment. Name the technological system that you studied.

---

- a. i.** Name a negative environmental effect associated with the operation of the system.

---

- ii.** Describe how this negative environmental effect impacts on the environment.

---

---

- iii.** Suggest a method for reducing this negative environmental effect.

---

---

1 + 2 + 1 = 4 marks

- b.** Name and describe a positive effect of the technological system on the environment.

---

---

2 marks

Total 6 marks

**Question 4**

A sluice gate controls the flow of water into an irrigation channel on a farm. The following drawing, Figure 1, shows a manually operated sluice gate.

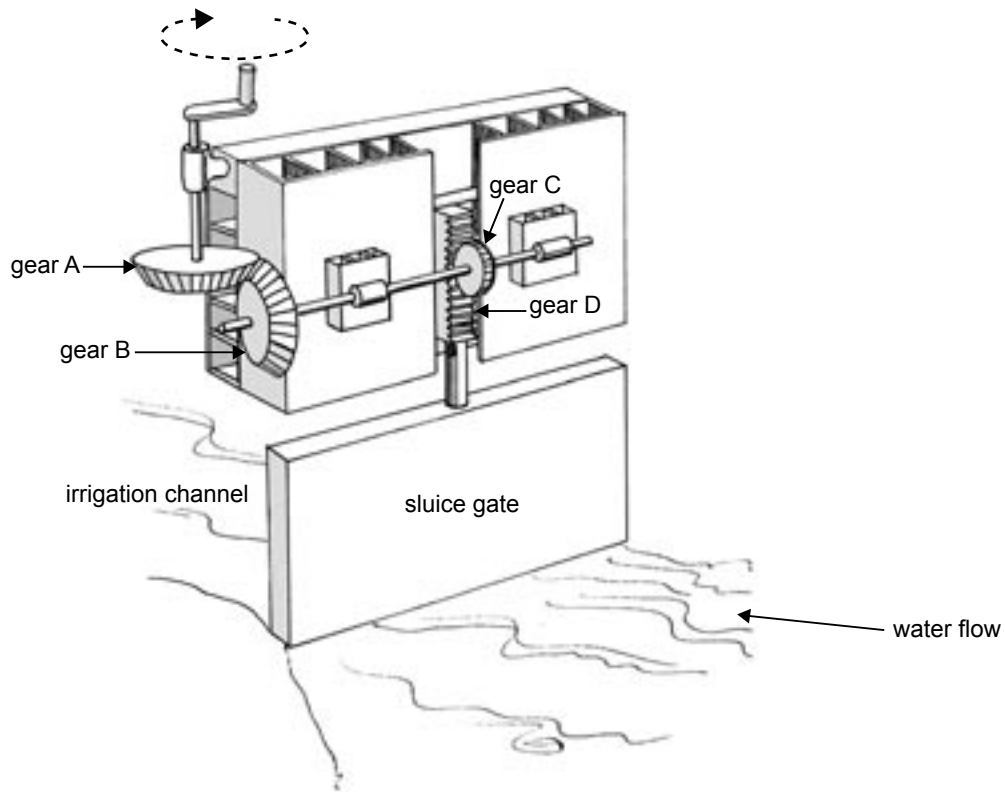

**Figure 1**

- a. Describe the operation of the sluice gate in terms of its input, process and output.

Input \_\_\_\_\_

\_\_\_\_\_

Process \_\_\_\_\_

\_\_\_\_\_

Output \_\_\_\_\_

\_\_\_\_\_

3 marks

The four gears in the sluice gate system (Figure 1) are labelled **gears A, B, C** and **D**. Three of the gears rotate either in a clockwise or anticlockwise direction. One of the gears can move only in an upward or downward direction.

- b.** If **gear A** moves in a clockwise direction as illustrated in Figure 1, write the direction of movement of each of the other gears in the table below. You must use the words clockwise or anticlockwise and up or down.

Gear A	Gear B	Gear C	Gear D
Clockwise			

3 marks

- c.** What factor is likely to reduce the efficiency of the gear system?

\_\_\_\_\_ 1 mark

- d.** Name the two types of motion that occur in the gear system when the sluice gate is opening or closing.

\_\_\_\_\_ motion \_\_\_\_\_ motion 2 marks

The diagrams below (Figures 2 and 3) show the sluice gate being lifted to open the irrigation channel (Figure 2) and the sluice gate being pushed into the mud at the base of the irrigation channel when closing (Figure 3). The connecting rod is subject to different forces when opening and when closing the sluice gate.

- e.** Name the type of force acting on the connecting rod on the line provided below each diagram.

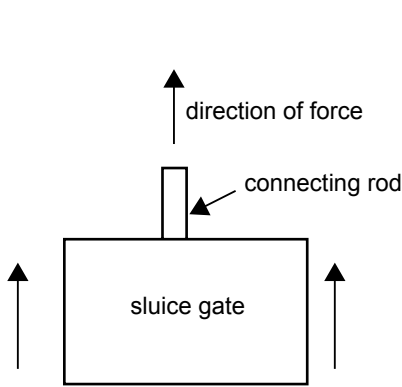

**Figure 2.** Lifting sluice gate

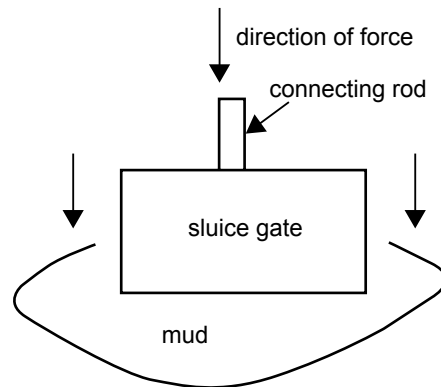

**Figure 3.** Closing sluice gate

Force \_\_\_\_\_ Force \_\_\_\_\_

2 marks

Over the summer period the sluice gate is not used and it becomes locked into the dried mud at the bottom of the irrigation channel. The manually operated gear system is unable to lift the sluice gate.

- f. On the diagram below (Figure 4) draw a lever and pivot that will gently lift the sluice gate from the dried mud. Mark in the correct places on your lever the load (**l**) the effort (**e**) and the fulcrum (**f**).

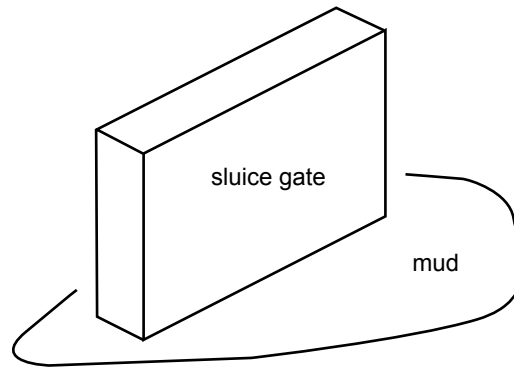

**Figure 4**

3 marks

Total 14 marks

**CONTINUED OVER PAGE**

**TURN OVER**

**Question 5**

The manual system (Figure 1 in Question 4) is to be replaced by a new system that uses the subsystems listed in the block diagram below (Figure 5). The sluice gate will then operate automatically. The new system is powered by a heavy duty 24 volt DC battery connected to the solenoid. A solenoid is a piston and cylinder that is operated by an electromagnet. For environmental reasons the irrigation will take place at night. To create sufficient water pressure the sluice gate will open only when the water level reaches the top of the sluice gate and when night falls.

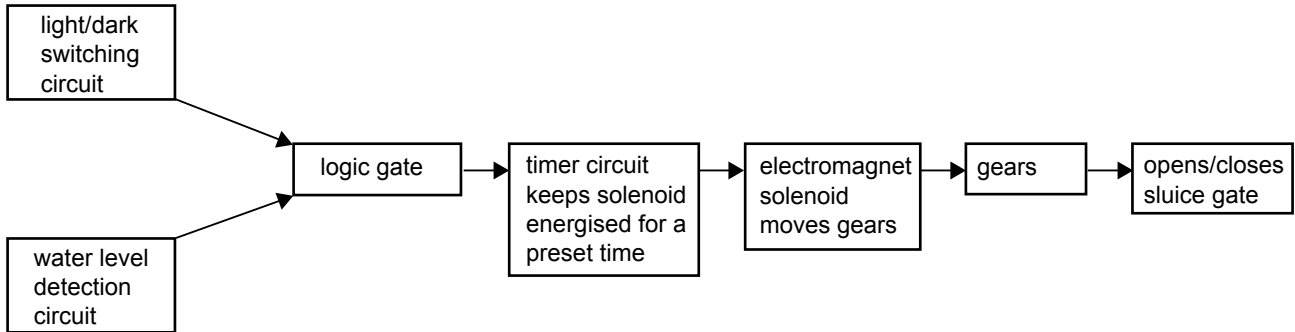

**Figure 5.** Block diagram of operation

Both the water level detection circuit and the light/dark switching circuit must produce an output logic level of 1 to turn the logic gate on.

- a. From the three logic gates illustrated below, name the logic gate that will allow the circuit to operate as described above. Explain why you chose this logic gate.

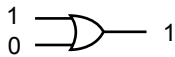

OR gate

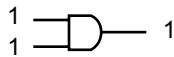

AND gate

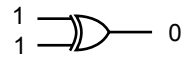

Exclusive OR gate

Name of gate \_\_\_\_\_

Explanation \_\_\_\_\_

\_\_\_\_\_

\_\_\_\_\_

1 + 2 = 3 marks

- b. The sluice gate pictured below (Figure 6) shows the position (x) of one water level sensor for the water level circuit. On the diagram (Figure 6) mark with the letter y the position of the second sensor.
- Note: The sluice gate only opens when there is maximum water. **The water level must touch both sensors x and y.**

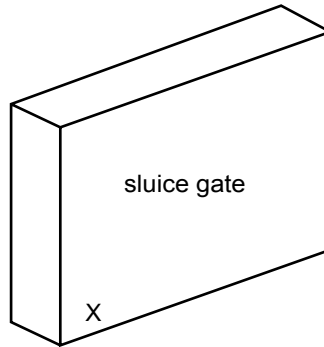

Figure 6

1 mark

- c. Explain in detail how the automatic sluice gate system operates as a closed-loop system. You may use words and/or diagrams.

---

---

---

3 marks

Total 7 marks

**TURN OVER**

**Question 6**

Illustrated below (Figure 7) are electronic component symbols that can be found in the three electronic circuits that now control the sluice gate.

a. Name each component on the line provided.

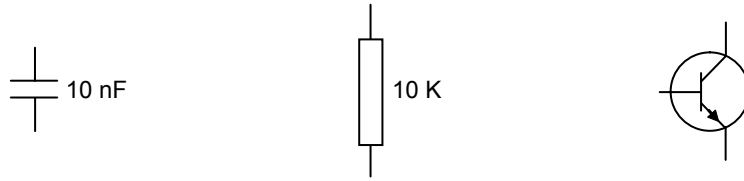

\_\_\_\_\_

\_\_\_\_\_

\_\_\_\_\_

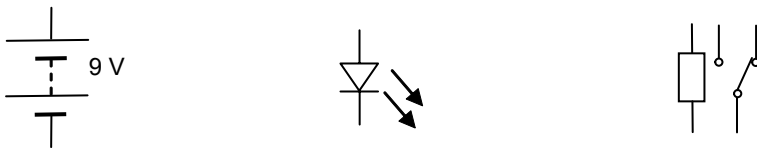

\_\_\_\_\_

\_\_\_\_\_

\_\_\_\_\_

**Figure 7**

6 marks

b. i. The following symbol has the leads b, c and e. What do the letters b, c and e stand for on this symbol?

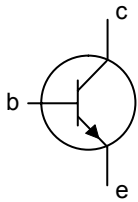

**b** \_\_\_\_\_

**c** \_\_\_\_\_

**e** \_\_\_\_\_

ii. State one function of this component.

\_\_\_\_\_

3 + 1 = 4 marks

- c. Calculate the current drawn by the system if the sluice gate has a power consumption of 1.2 kW from a 24 volt supply. Refer to formula on page 20 and show all working.

1 + 1 = 2 marks

Total 12 marks

**CONTINUED OVER PAGE**

**TURN OVER**

**Question 7**

The task of lifting the sluice gate is now performed by a solenoid and gear arrangement (Figure 8).

A solenoid is a piston and cylinder that is operated by an electromagnet.

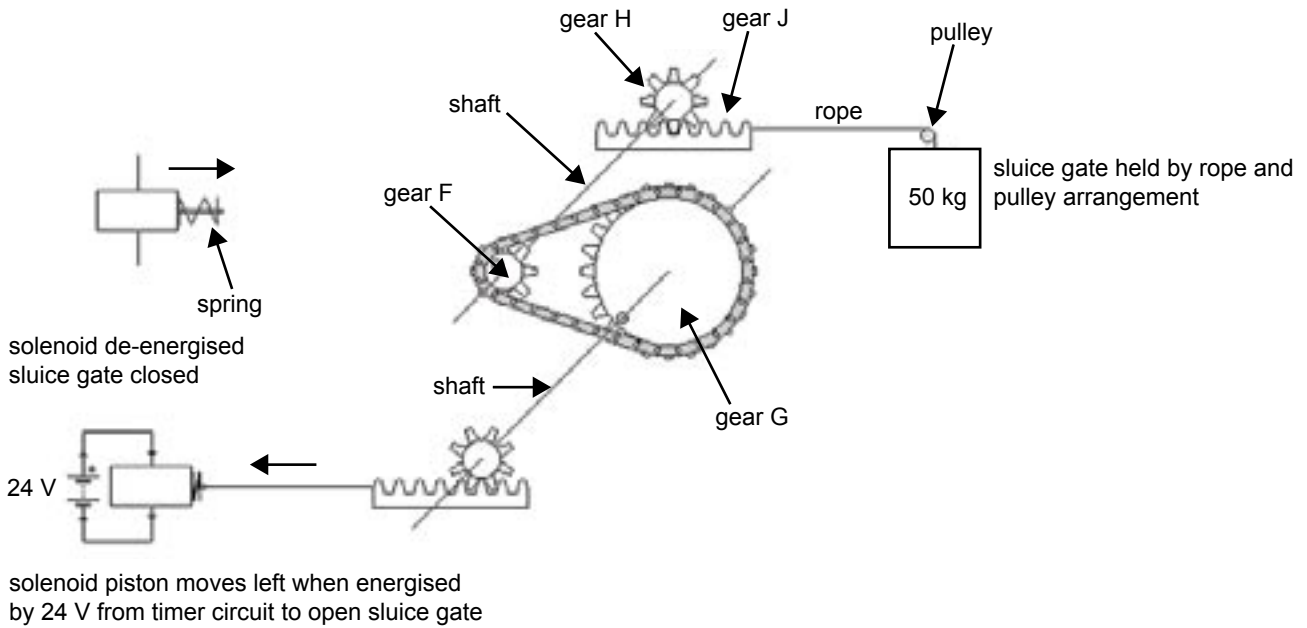

**Figure 8**

The above diagram (Figure 8) shows the sluice gate in the open position.

- a. Describe the **two** factors in the system which act together to close the sluice gate when the solenoid is de-energised.

---



---



---

2 marks

- b. Name the component which joins gear F to gear G.

---

1 mark

- c. Explain why gear F and gear G will always turn in the same direction.

---



---

1 mark

- d.** Gear J will need to move 200 mm to lift the sluice gate into the open position. Gear J has a pitch of 5 degrees. How many teeth will gear H require to move gear J 200 mm? Refer to formula on page 20 and show all working.

1 + 1 = 2 marks

Total 6 marks

**CONTINUED OVER PAGE**

**TURN OVER**

**Question 8**

When setting up the new automatic sluice gate system, diagnostic tests of measurement are needed on the individual subsystems before the system is used. These diagnostic checks can be either mechanical or electrical/electronic.

Read again carefully all the information supplied on the new automatic sluice gate system (Questions 5 and 7).

- a. Name a mechanical test that could be performed on one of the sluice gate subsystems.

---

1 mark

- b. Describe briefly the purpose of this test.

---

---

1 mark

- c. Name a measuring device that could be used to perform the test.

---

1 mark

- d. Name an electrical/electronic test that could be performed on one of the sluice gate subsystems.

---

1 mark

- e. Describe briefly the purpose of this test.

---

---

1 mark

- f. Name a measuring device that could be used to perform the test.

---

1 mark

Total 6 marks

**Question 9**

The automatic system has the sluice gate raised and lowered by a rope (Figure 9).

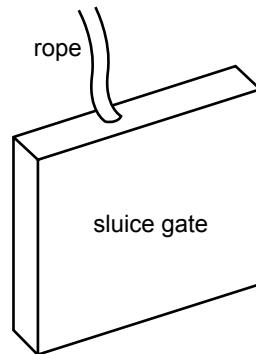

**Figure 9**

The sluice gate needs to be mounted between two runner guides to keep it in place.

- a. What effect will the rising water have on the sluice gate if there are no runners to guide and keep the sluice gate in place?

---



---

1 mark

The following drawing, Figure 10, shows a length of H section steel that could be modified to use as runners to support the sluice gate. Many other metal profiles could also be used to design runners.

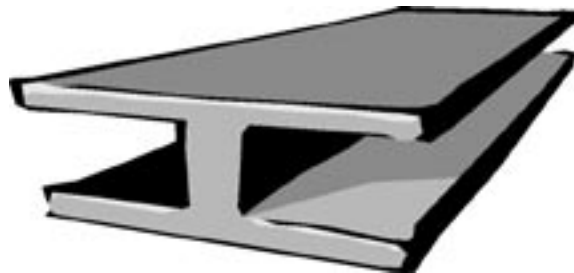

**Figure 10**

- b. i. Produce a drawing below which shows the sluice gate supported by two runners. Your drawing should show the sluice gate in the open position.
- ii. On your drawing include and label a device that will keep the sluice gate in the open position to allow continuous irrigation.

2 + 2 = 4 marks

Total 5 marks

**TURN OVER**

**Question 10**

On the block diagram below (Figure 11) describe the input, process and output of the automatic sluice gate system. Include in **each** subsystem box the name of an electrical, an electronic and a mechanical subsystem that make up the system.

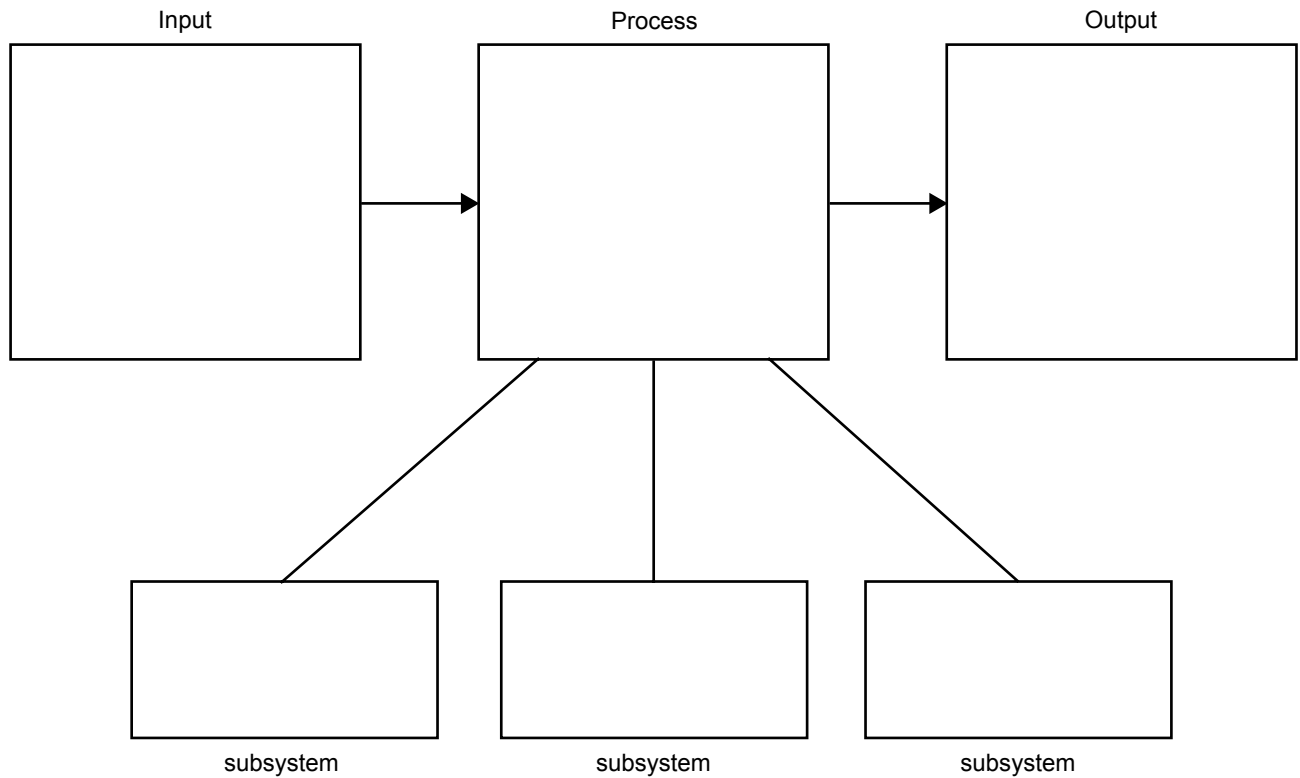

**Figure 11**

6 marks

Total 6 marks

**Question 11**

A farm has a number of irrigation channels that have been converted to automatic operation. Electricity from rechargeable lead acid batteries will run the system. These will require replacement as they wear out.

A power source for recharging batteries has to be selected. This can be coal power or wind generators as the area has many days of high winds.



Wind generators



Coal power station and transmission lines

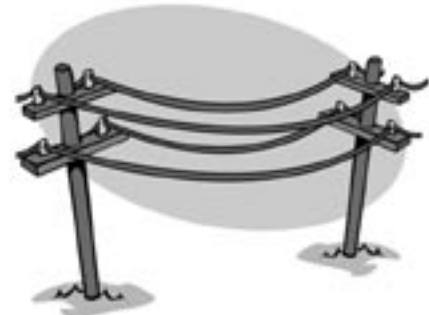

- a. State one advantage of using wind generators and coal power stations.

Wind generators \_\_\_\_\_

\_\_\_\_\_

Coal power stations \_\_\_\_\_

\_\_\_\_\_

2 marks

- b. State one disadvantage of using wind generators and coal power stations.

Wind generators \_\_\_\_\_

\_\_\_\_\_

Coal power stations \_\_\_\_\_

\_\_\_\_\_

2 marks

- c. Name **two** advantages of using solar energy to charge the batteries.

\_\_\_\_\_

\_\_\_\_\_

\_\_\_\_\_

2 marks

Total 6 marks

**TURN OVER**

**Formulas**

$$P = IV$$

$$V = \frac{P}{I}$$

$$I = \frac{P}{V}$$

$$\text{number of teeth on driver gear} = \frac{\text{distance moved by driven gear}}{\text{driver gear pitch}}$$

**END OF QUESTION AND ANSWER BOOK**

