

Instructions

Answer **all** questions in the spaces provided.

Question 1

As part of your course you constructed an integrated system which required a control device. Design and/or modification work to the system was also required.

Name the integrated system you constructed.

- a. What are the **two** features of your system that allow it to be categorised as an integrated system?

2 marks

Name the design or modification work you carried out on your system.

- b. Explain in detail the intended purpose of the design or modification work.

2 marks

- c. All systems can be described in terms of their input, process and output.

- i. On the block diagram below briefly describe the input, process and output for the system you named above. **Specific terms must be used.**

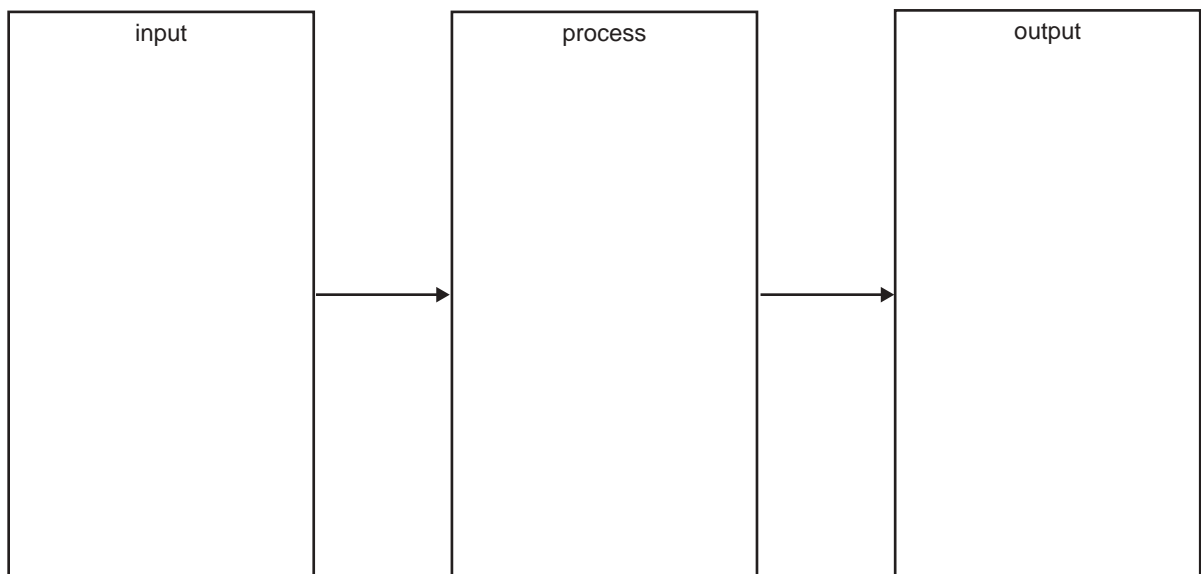

All systems require an energy source and, in the process of operation, the system converts the energy source into a usable form.

- ii.** Explain in detail how the **process** of operating the system you named converts an energy source into a usable form. **Specific terms must be used.**

In answering this question, you may either describe and/or illustrate and label this conversion.

3 + 3 = 6 marks

Impact on the environment

All systems have some negative impact on the environment.

- d.** Name the negative impact the system you named has on the environment.

1 mark

Question 2**Movement subsystem and testing**

The system you named in **Question 1** will also have a mechanical subsystem(s) which produces movement. Name the subsystem.

-
- a. Your subsystem(s) produced some form of movement. Using correct terminology name the type of movement.

1 mark

- b. What is the purpose of this movement?

1 mark

The action of this movement will have to meet acceptable performance criteria that can be tested.

- c. State **two** performance criteria.

2 marks

- d. Name an item of test equipment that can measure the performance of the motion described in **part a**. This test equipment must be able to measure in a scientific unit.

1 mark

- e. Explain in detail how the named item of test equipment can measure the subsystem movement against the performance criteria.

In answering this question, you may either describe and/or illustrate and label how this can be measured.

3 marks

The operating principles of all subsystems can be summarised as hydraulic, pneumatic, mechanical, electrical and electronic.

- f. Which principle **best** describes the operation of the movement you named in **part a**?

1 mark

Total 9 marks

Question 3**Electromotive force subsystem and measurement**

The system you named in **Question 1** will also have an electrical/electronic subsystem(s).

The terms AC and DC stand for alternating current and direct current.

- a.** Your subsystem(s) will have a voltage. This can be either AC or DC or both if a mains approved plug pack is used. Select and name the voltage type that best describes the one used in the operation of your subsystem(s).

1 mark

- b.** Describe in detail why your named voltage type is AC or DC.

2 marks

The voltage of the subsystem will be of a value that can be measured.

- c. i.** State the value of this voltage.

- ii.** Why is this voltage value suitable to meet the subsystem performance criteria?

1 + 1 = 2 marks

- d.** Name an item of test equipment that can measure the voltage described in **part a**. This test equipment must be able to measure in a scientific unit.

1 mark

- e. Explain in detail how the named item of test equipment can measure the subsystem voltage.
In answering this question, you can either describe and/or illustrate and label how this can be measured.

3 marks

Total 9 marks

Question 4

Merry-go-rounds have been a traditional amusement ride in fairgrounds for many years.

Before electricity, fairground rides were driven by steam engines. An example is shown in Figure 1.

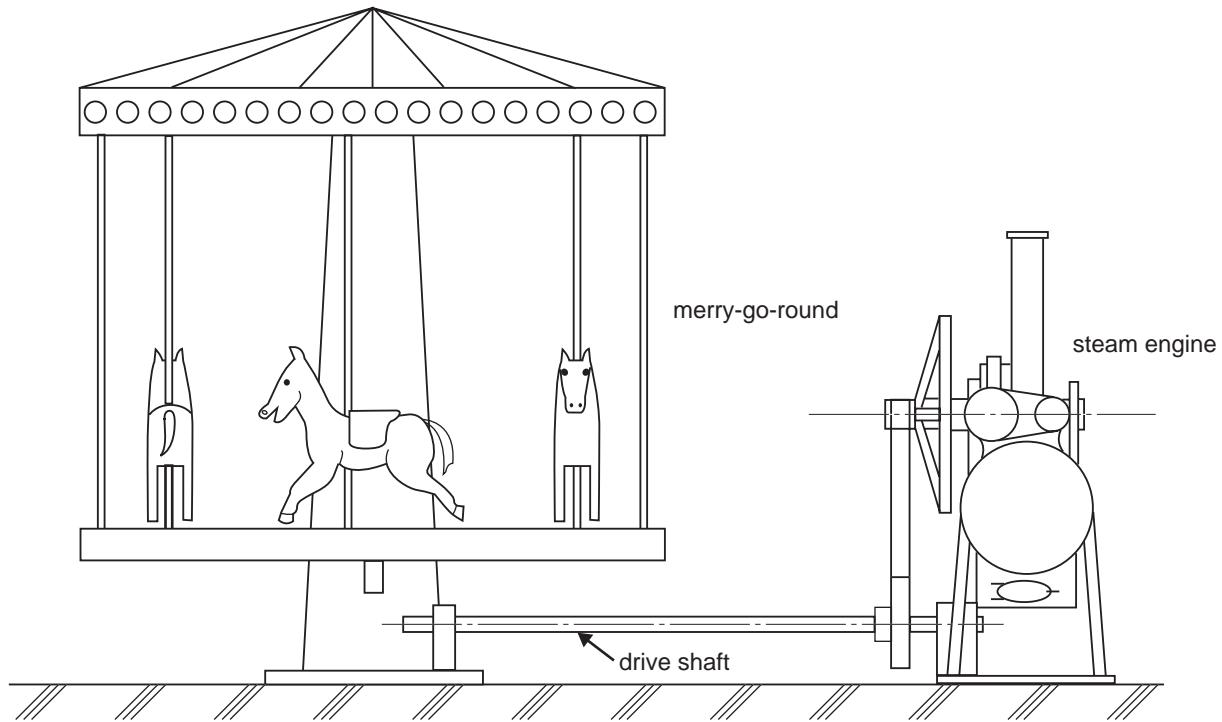
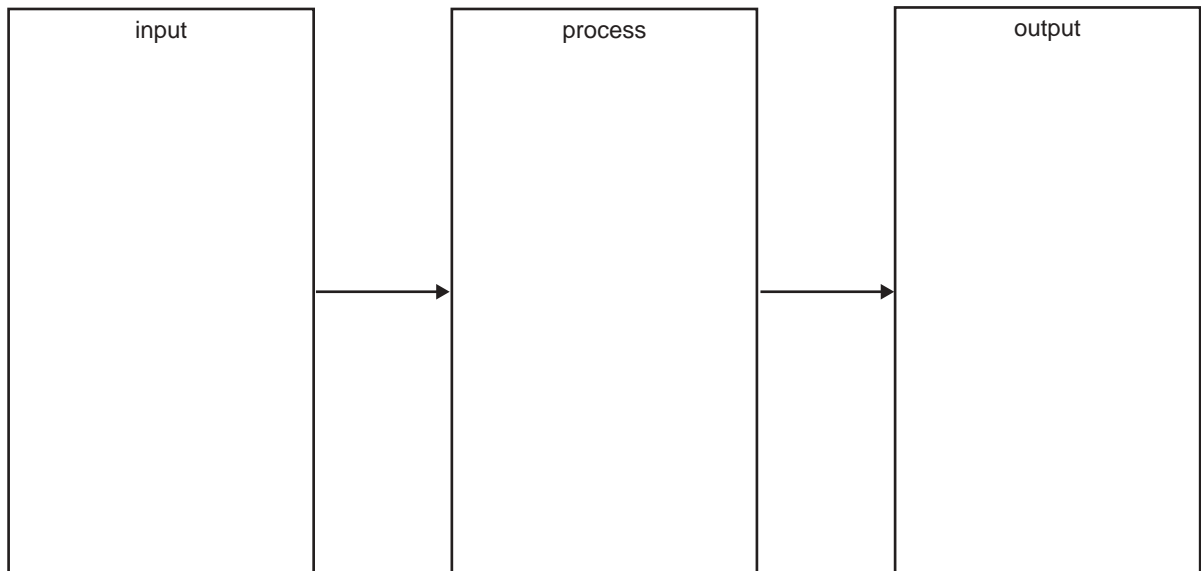

Figure 1

- a. Describe the operation of the **merry-go-round** in terms of its input, process and output.



3 marks

A pulley subsystem is used on the steam engine to drive the merry-go-round (Figure 2).

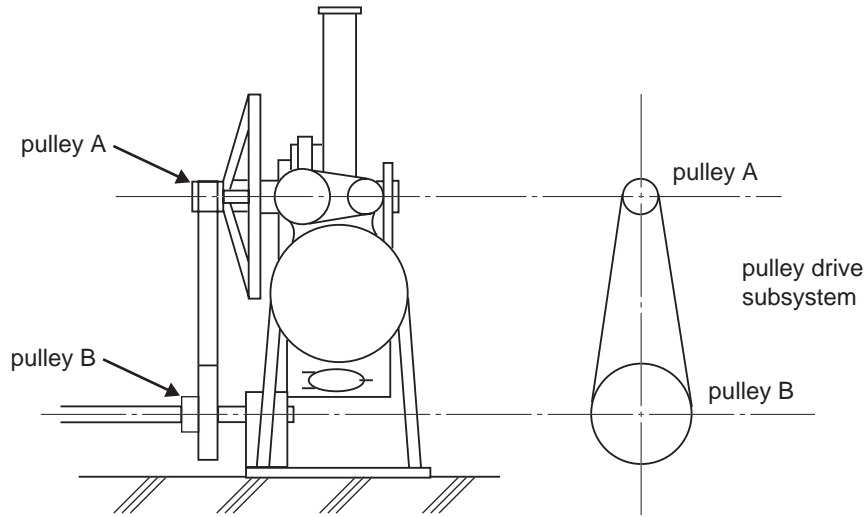

Figure 2

- b. i.** Redraw the pulley drive subsystem as shown in Figure 2 (pulley A and pulley B), and incorporate a design for a mechanism that will allow the pulleys to be engaged or disengaged.

- ii.** Describe how your design operates.

2 + 2 = 4 marks

- c. Complete the drawing of the pulley system below, so that the merry-go-round will go in the reverse direction, by modifying the pulley and belt system only.

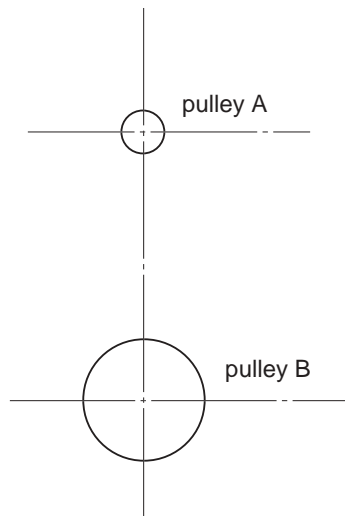

1 mark

- d. The steam engine (pulley A) rotates at 12 revs per minute (rpm) and the shaft to drive the merry-go-round (pulley B) is to rotate at 3 rpm. Calculate the diameter of pulley B. The diameter of pulley A is 12 cm. Refer to formula on page 21.

2 marks

- e. i. On Figure 3 add a gear system that would enable shaft A to drive shaft B (place gear A on shaft A and gear B on shaft B).

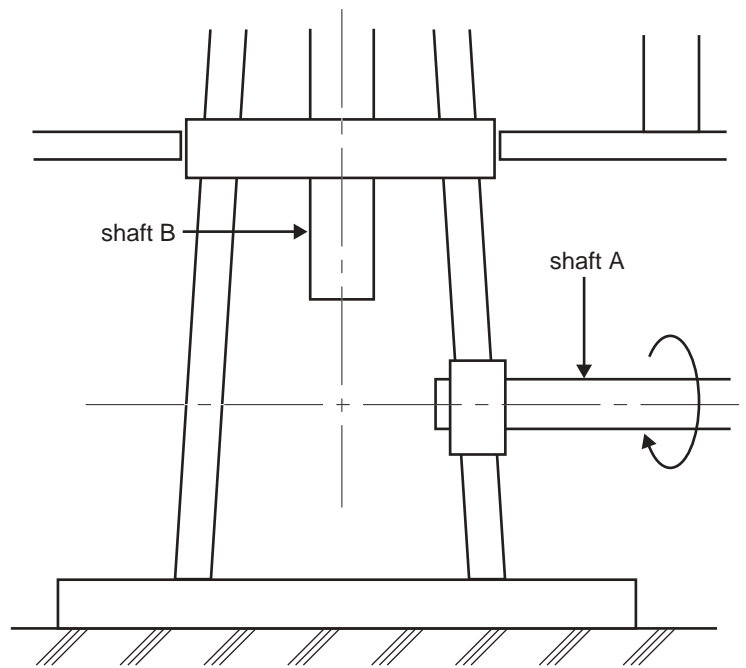

Figure 3

- ii. Name the type of gears that you have drawn.

2 + 1 = 3 marks

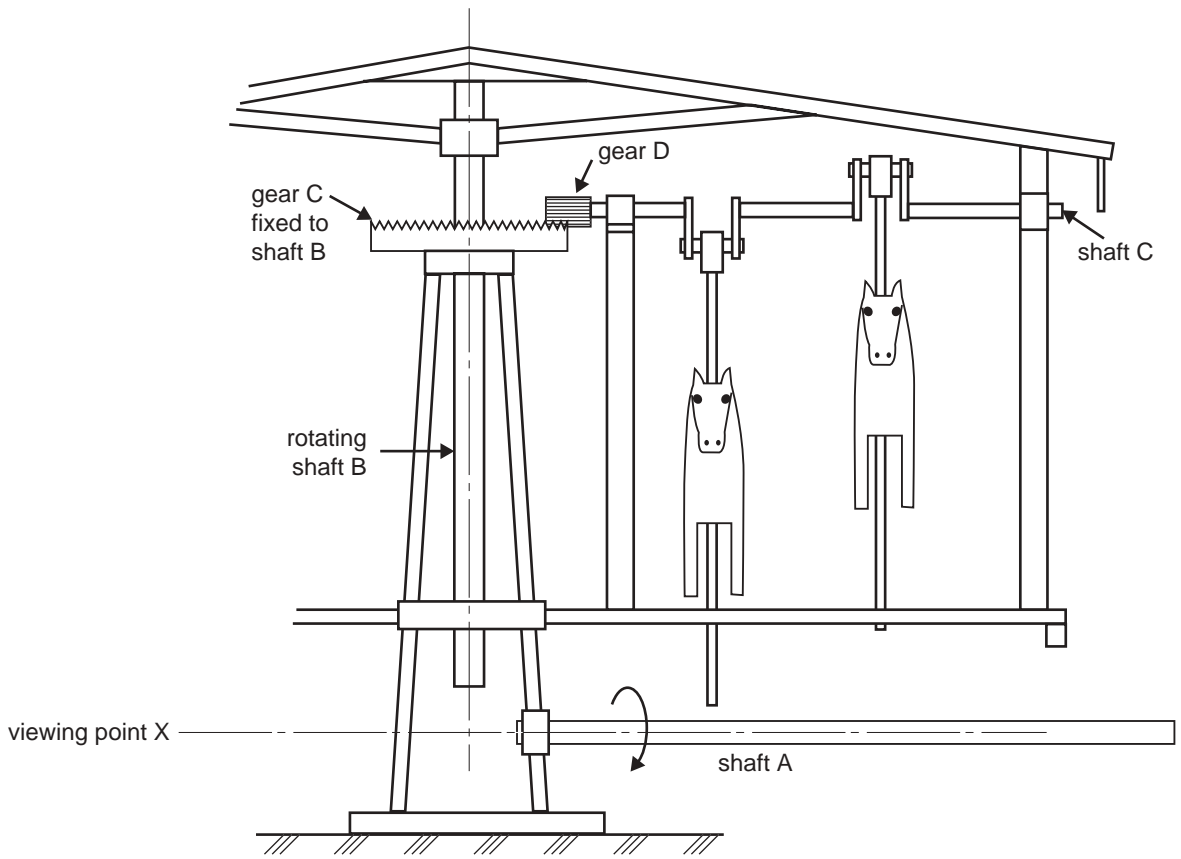

Figure 4

- f. If shaft A in Figure 4 rotates clockwise from the viewing point X, in which direction will shaft C rotate?

1 mark

- g. On the diagram below (Figure 5) label the effort, fulcrum and the load acting on shaft C.

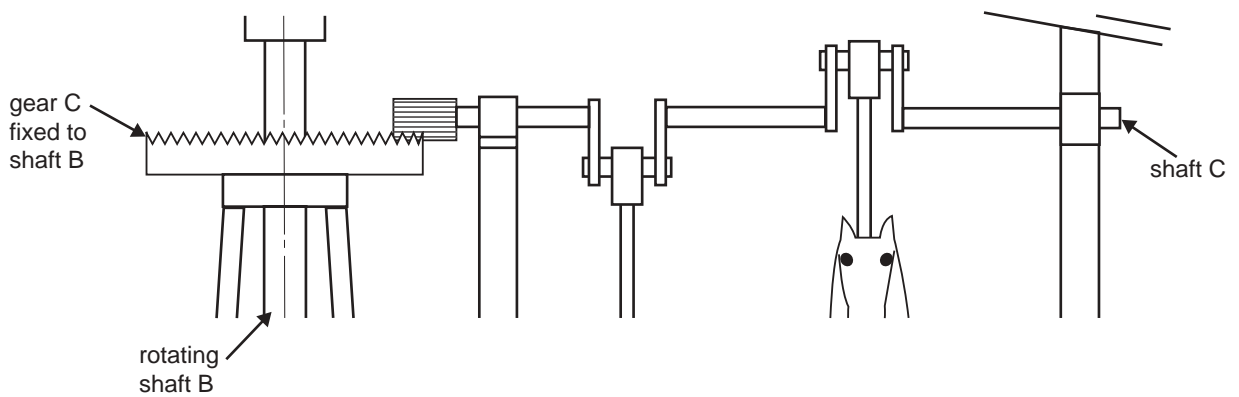

Figure 5

3 marks

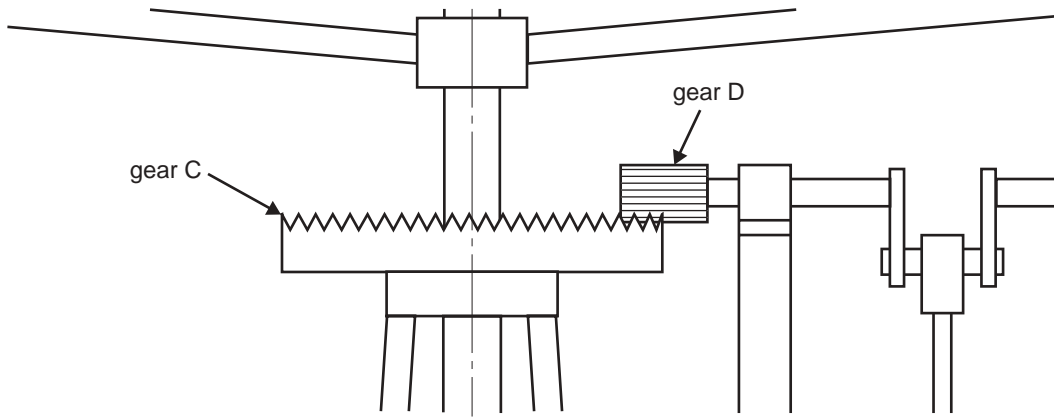

Figure 6

- h.** If gear C has 60 teeth and gear D has 12 teeth (Figure 6) what is the gear ratio of these two gears?

1 mark

To meet modern day requirements the steam engine was replaced by an electric motor with an rpm of 1200. The drive shaft of the merry-go-round rotates at 3 rpm. The system will now need to have a reduction gear ratio of 400:1. This is very difficult using a single gear.

- i.** Design a gear system, to give a ratio of 400:1, to connect the output shaft of the electric motor to the input shaft of the merry-go-round. (Complete the diagram below and state the gear ratio of each set of gears.)

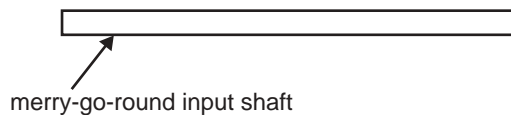
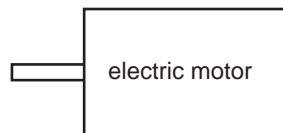

3 marks

Total 21 marks

Question 5

The electric motor of the modern merry-go-round has an electrical reversing circuit.

The following components comprise the motor reversing circuit: a push button switch that switches the relay and a 12 volt DPDT relay that switches the motor.

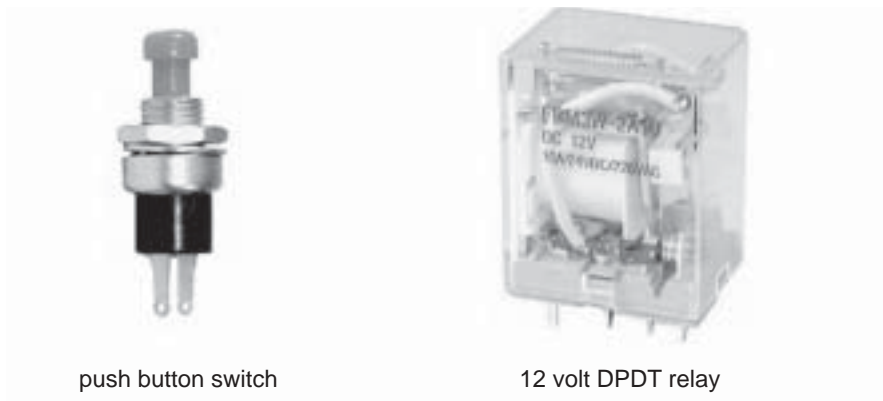

- a. Figure 7 shows the relay connections. Draw in **two** additional connections on the relay that will reverse the DC motor when the button is pushed.

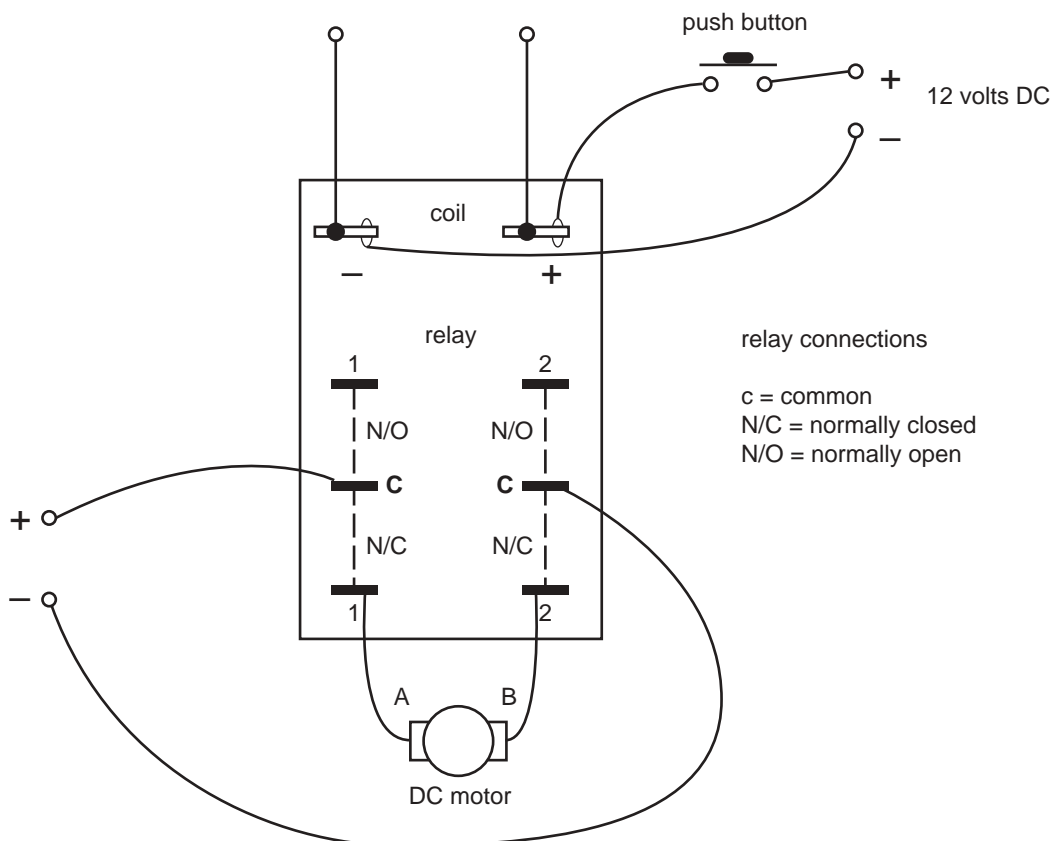

Figure 7

2 marks

Often a power diode is placed across the relay coil in reverse bias. This dissipates the charge generated by the coil when it is de-energised (back EMF). The diode is placed between the two connections.

- b. On Figure 7, draw between the two connections a standard diode symbol, **connected in reverse bias to supply**.

1 mark

The electric motor also has an electronic motor speed control circuit. This is shown in Figure 8. The motor speed control circuit can control the speed at which the merry-go-round turns.

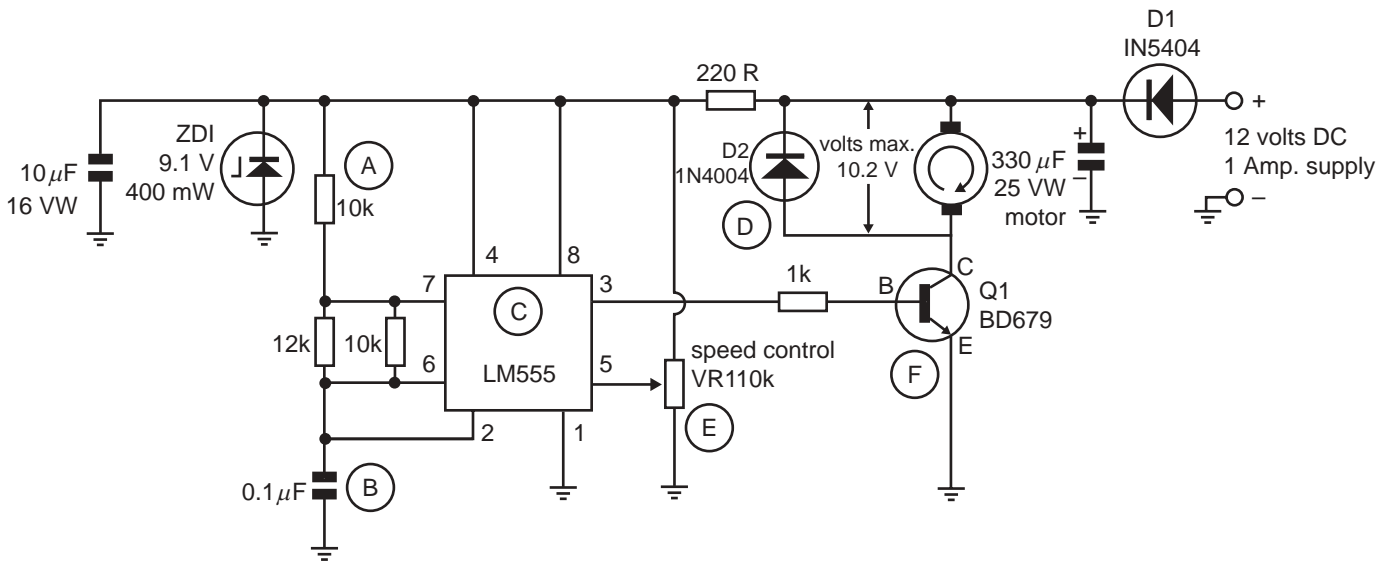

Figure 8

- c. The motor speed control circuit, Figure 8, has six electronic components labelled A – F. Write the correct name of the component next to the circled letter.

Letter	Components
(A)	
(B)	
(C)	
(D)	
(E)	
(F)	

6 marks

The circuit designer has used two resistors in configuration across pins 6 and 7 of the LM555.

- d. What type of connection configuration are the resistors across pins 6 and 7?

1 mark

- e. Calculate the total resistance (R_T) across pins 6 and 7.

Answer using correct units.

Refer to formula on page 21.

3 marks

- f. State the voltage that would be present on pin 1 of the LM555.

1 mark

- g. The full 10.2 volts is supplied to the motor and the maximum current of 700 mA is drawn.

Calculate the maximum power used by the motor and answer using correct units.

Refer to formula on page 21.

3 marks

- h. The circuit is supplied with 12 volts DC with a maximum input current of 1 A. The DC motor can draw the maximum current of 700 mA when supplied with 10.2 volts.

Calculate the efficiency of the speed controlling circuit and give your answer as a percentage.

Refer to formula on page 21.

3 marks

Total 20 marks

TURN OVER

Question 6

The merry-go-round is set up to run off the electric motor. You are now required to run a practical test to see that the gears allow the merry-go-round to spin at 3 rpm. Look at the drawing (Figure 9) of the merry-go-round and the person.

You are the person in Figure 9. Use where you are standing as a reference point and devise a test to see if the merry-go-round spins at 3 rpm. You must use at least **one** item of test equipment that measures in scientific units.



Figure 9

- a. Name the item of test equipment used for this test.

1 mark

- b. Name the scientific units that are measured with this item of test equipment.

1 mark

Use Figure 10 below for the following question.

- c. Use where you are standing as a reference point. Describe and draw and label how you would conduct the test.



Figure 10

3 marks

Even when powered by the electric motor the merry-go-round will not be 100% efficient.

- d. Name one **major** factor that you think will contribute to efficiency loss in the operation of the merry-go-round.

1 mark

- e. Describe how you think the factor named in **part d.** contributes to the efficiency loss in the operation of the merry-go-round.

2 marks

- f. How could the efficiency loss be reduced?

1 mark

Question 6 – continued
TURN OVER

A first step in establishing the efficiency of the system could be to measure the current and voltage of the system and then calculate the system's power consumption.

- g.** Figure 11 below shows the input voltage terminals and the electric motor. Draw, in their correct positions, a voltmeter and an ammeter.

Include on your diagram all necessary connections and labelling. The polarity is not required.



Figure 11

3 marks

Total 12 marks

Question 7

The steam engine generates power by burning coal at the site of the merry-go-round.

- a.** Discuss the environmental advantages and disadvantages of this.

2 marks

The electric motor requires power from a distant coal-fired power station.

- b.** Discuss the environmental advantages and disadvantages of this.

2 marks

Total 4 marks

Formulas

$$\frac{\text{Diameter pulley B}}{\text{Diameter pulley A}} = \frac{\text{rpm pulley A}}{\text{rpm pulley B}}$$

$$\text{Gear ratio} = \frac{\text{teeth on driver}}{\text{teeth on driven}}$$

$$R_t = \frac{R_1 \times R_2}{R_1 + R_2}$$

$$P = V \times I$$

$$\text{Efficiency} = \frac{\text{output power}}{\text{input power}} \times \frac{100}{1}$$