



**Instructions**

Answer **all** questions in the spaces provided.

**Question 1**

As part of your course you constructed a system with two separate subsystems from the mechanical and electrical/electronic categories. The system also required a control device.

Name the system you constructed \_\_\_\_\_

- a. What common term is used to describe systems that are made up of mechanical and electrical/electronic subsystems?

\_\_\_\_\_ 1 mark

- b. i. State whether your system was controlled through an open or closed loop system.

\_\_\_\_\_

- ii. Describe in detail how control was achieved in your system.

In your answer you should name clearly the component or components that were responsible for achieving this control.

\_\_\_\_\_  
\_\_\_\_\_  
\_\_\_\_\_  
\_\_\_\_\_

1 + 2 = 3 marks

- c. Name a major mechanical subsystem **and** a major electrical/electronic subsystem that made up the system named above.

Mechanical subsystem \_\_\_\_\_

Electrical/electronic subsystem \_\_\_\_\_

2 marks

Total 6 marks

### Question 2

All systems and subsystems convert some form of energy into a desirable output that people can use.

All systems and subsystems also produce undesirable outputs that have an impact on the environment. This can be summarised in the following block diagram, Figure 1.

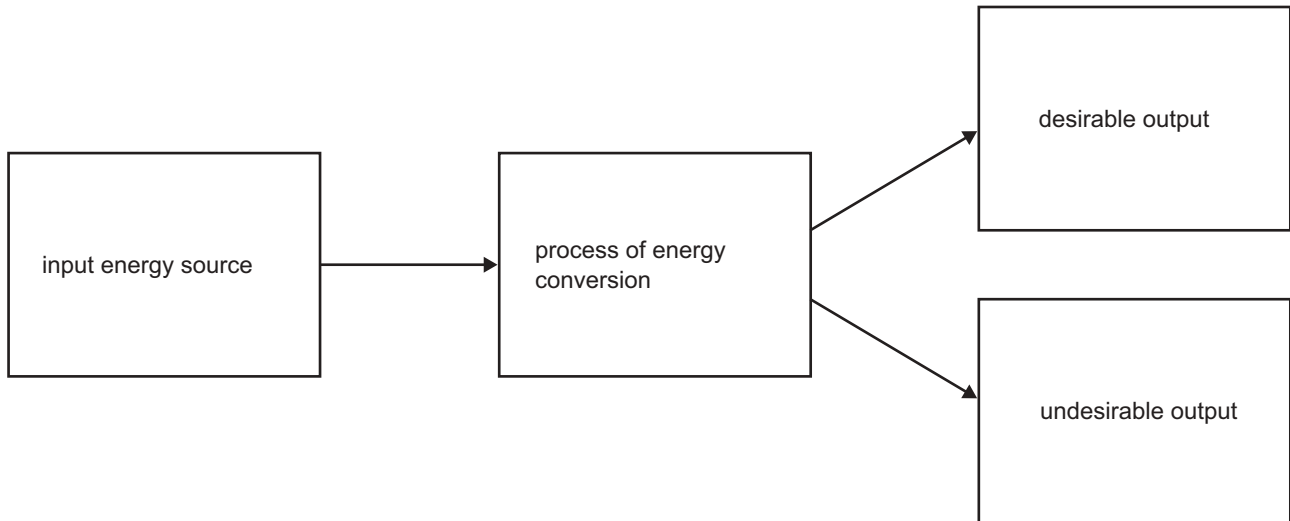

**Figure 1**

- a. Using the block diagram template below describe the **(input) energy source**, the **process of energy conversion** and a **desirable** and **undesirable output** for the **mechanical subsystem** that you named in **Question 1c**.

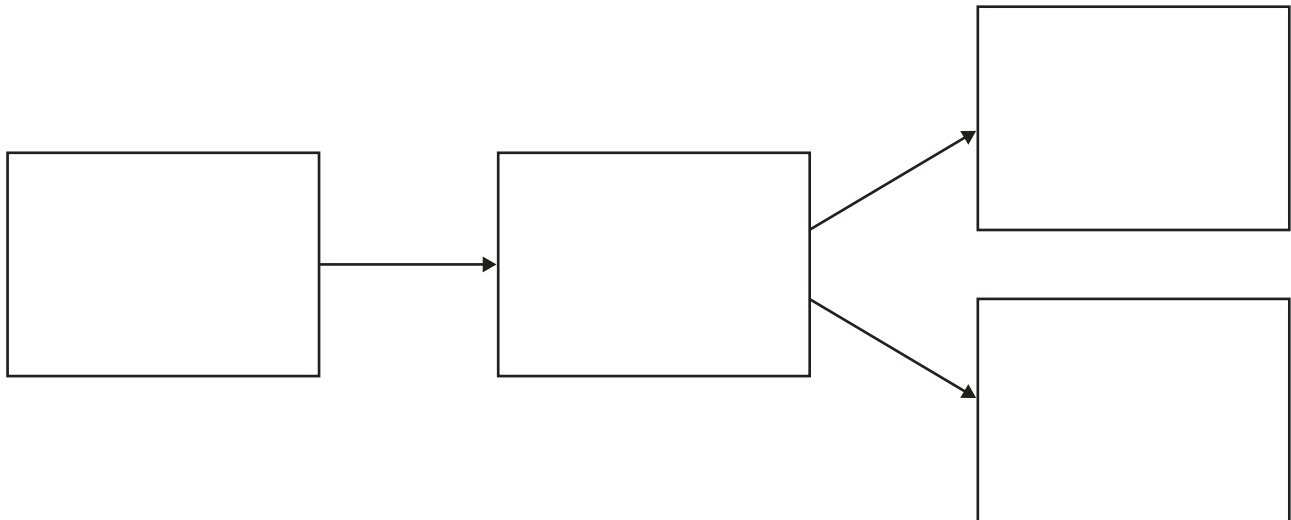

4 marks

All mechanical systems/subsystems will create some form of motion in the output stage. The motion can be summarised using the following terms: rotary, linear, reciprocating and oscillating.

- b. Name the type of motion that best summarises the motion of the mechanical subsystem that you named in **Question 1c**.

---

1 mark

- c. Describe in detail how the output motion named in **part b.** is achieved. You may refer to the total mechanical subsystem operation in your description.

---

---

---

---

---

2 marks

- d. Name an item of test equipment that could be used to test or measure the motion described in **part b.** This test equipment must be able to measure in a scientific unit.

---

1 mark

- e. Describe in detail how this item of test equipment can be used to test or measure the output movement of the mechanical subsystem. State clearly in your description the scientific units of measurement that you will read in your test or measurement.

---

---

---

---

3 marks

**Impact on the environment**

Restate here the **undesirable** output that you named in **part a.**

---

- f. Explain in detail how this undesirable output impacts on the environment.  
**Make sure that you use specific terms here when referring to any effects. Terms such as smoke and pollution are general terms.**

---

---

---

---

---

3 marks

Total 14 marks

**Question 3**

- a. Using the block diagram template again, describe the **input energy source**, the **process of energy conversion** and a **desirable and undesirable output** for the **electrical/electronic subsystem** that you named in **Question 1c**.

Electrical/electronic subsystem \_\_\_\_\_

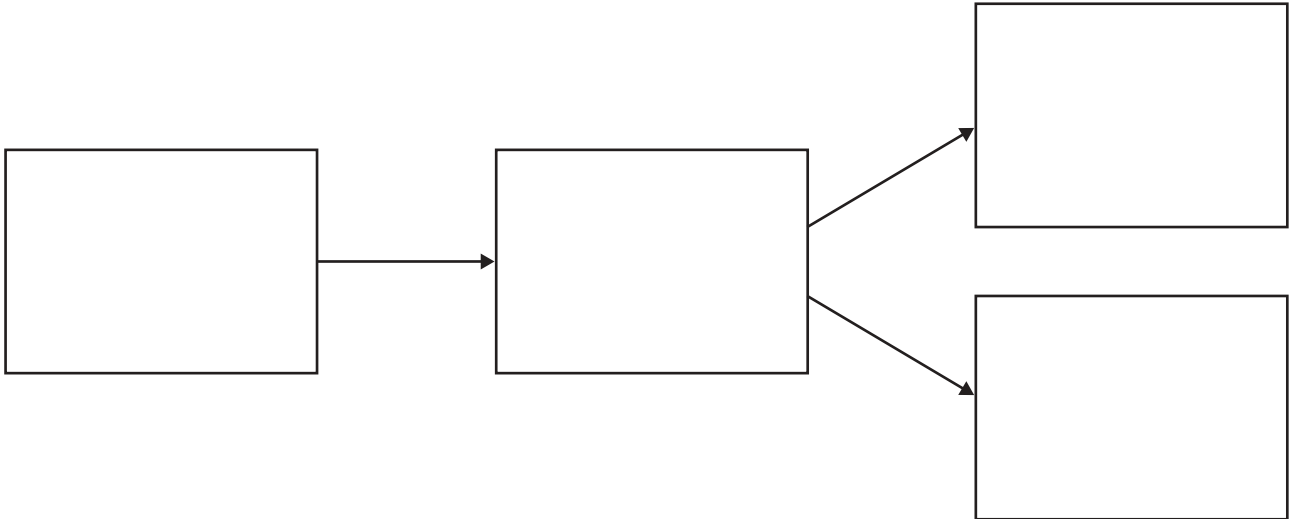

4 marks

The electrical input or output of your subsystem will always have a specific voltage and will either be AC or DC depending on the electricity source.

- b. Using the input or output electrical energy of the system that you named in **part a.**, state the specific voltage and whether it is AC or DC.

Voltage and type \_\_\_\_\_

2 marks

- c. On the graph below sketch your answer to **part b**.

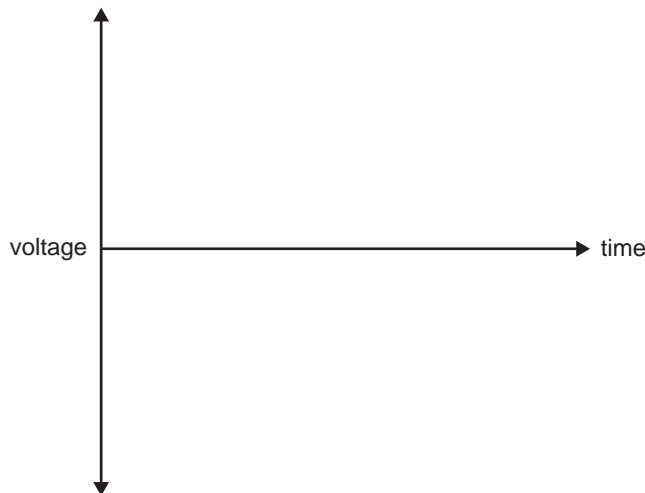

1 mark

You are required to carry out a test to measure the voltage.

- d. Name an item of test equipment that is suitable for measuring the voltage. This test equipment must be able to measure in a scientific unit.

\_\_\_\_\_

1 mark

e. Describe in detail the set-up procedures of the item of equipment named in **part d**.

---

---

---

---

2 marks

**Impact on the environment**

Both mechanical systems/subsystems and electrical/electronic systems/subsystems produce undesirable outputs. However, it is usually the mining, generation and/or disposal of the **input energy source** that creates the greatest impact on the environment.

State here the **input energy source** for the electrical subsystem named in **part a**.

---

f. Explain in detail how the mining, generation and/or disposal of this **input** energy source impacts on the environment.

**Make sure that you use specific terms here when referring to any effects. Terms such as smoke and pollution are general terms.**

---

---

---

---

---

3 marks

Total 13 marks

**Question 4**

Before electricity, water wheels were used to drive wheels and other devices. Gears similar to those shown in Figure 2 were used to drive millstones to turn wheat into flour.

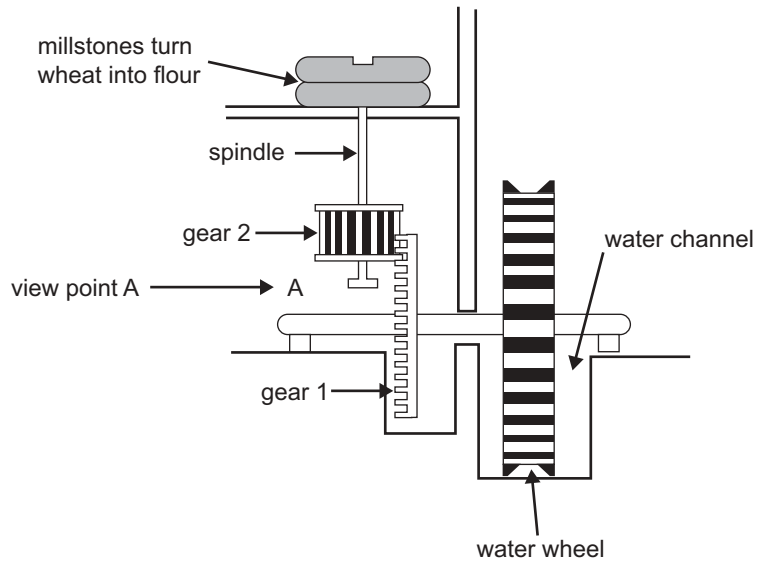
**Figure 2**

- a. Describe the operation of the water wheel system in terms of its input, process and output.

Input

---



---

Process

---



---

Output

---



---

3 marks

- b. If **gear 1**, viewed from view point A, turns anticlockwise, in which direction does **gear 2** turn when viewed from the same position?

---

1 mark

A water wheel is used to set up a garden water feature. A 240 volt AC water pump is used to take water to the top of the water wheel. The falling water causes the water wheel to turn, which then causes the hammer to hit the bell.

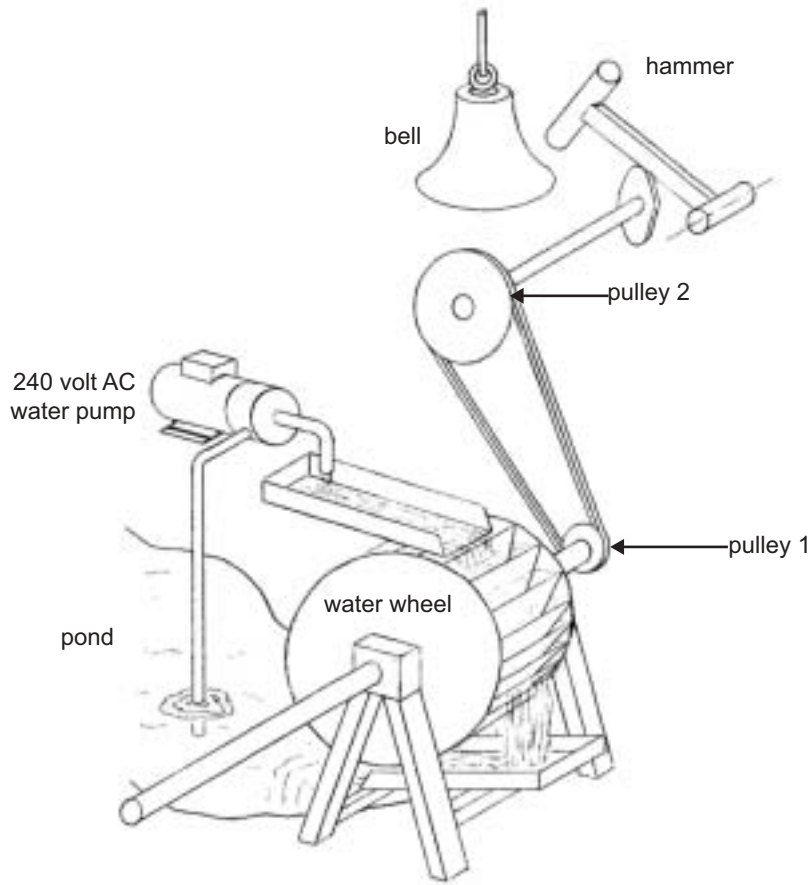

**Figure 3**

c. On the diagram below (Figure 4) clearly label the fulcrum, effort and load of the hammer.

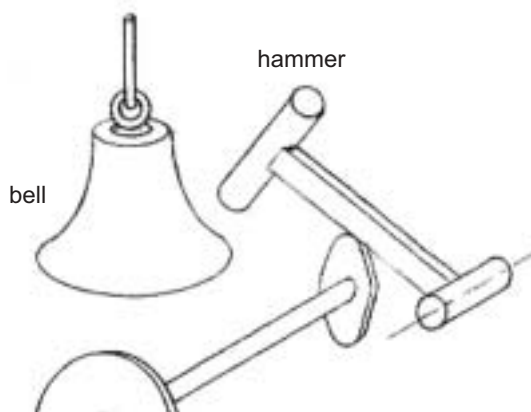

**Figure 4**

3 marks

d. Explain in detail the operation of the cam in Figure 4.

---



---



---



---

2 marks

A different style of bell is to be trialed as shown below in Figure 5 and Figure 6.

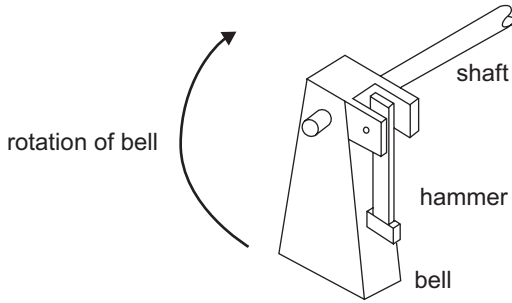

Figure 5

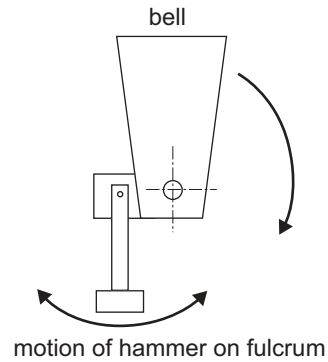

Figure 6

e. Using the terms effort, fulcrum and load, describe the operation of the bell (Figure 5 and Figure 6).

---



---



---



---

3 marks

f. Define the type of motion of the hammer in Figure 6.

---

1 mark

Both bell systems are driven by the pulley system shown in Figure 7.

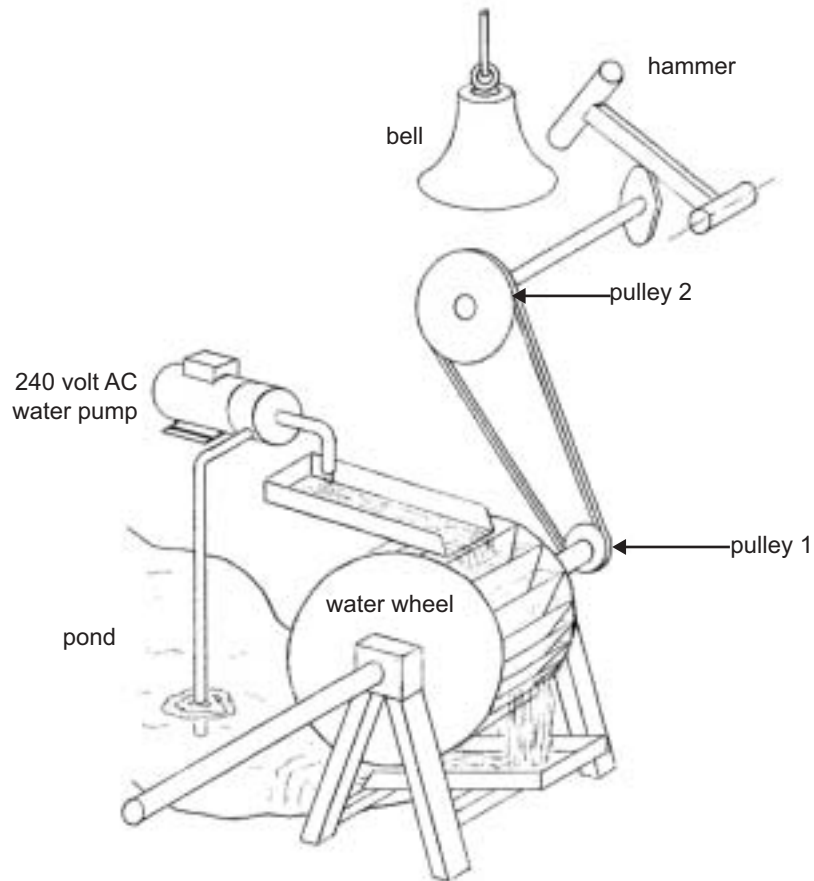

**Figure 7**

The bell will be tested to see what effect reversing the direction of pulley 2 will have on the bell's operation.

- g.** Draw a diagram of a pulley system that would enable pulley 2 to be rotated in the reverse direction. Label pulley 1 and pulley 2.

2 marks

- h.** The water wheel rotates at 60 rpm. Pulley 2 is required to rotate at 20 rpm. If the diameter of pulley 1 is 60 cm, calculate the diameter of pulley 2. Refer to Figure 7 and formula on page 19 when answering this question. Show all working.

2 marks

- i.** From the gears shown below, identify a bevel gear and a worm gear.

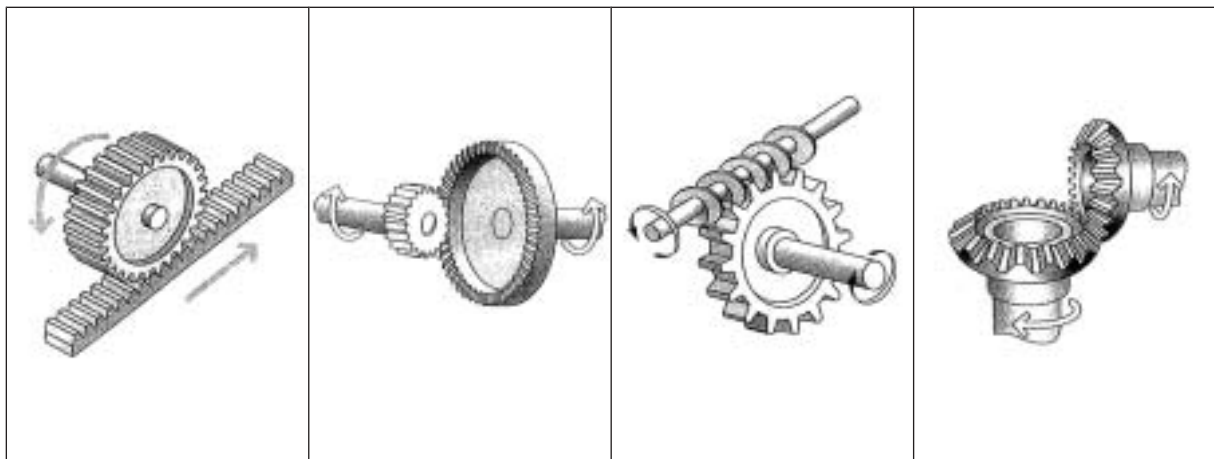

gear A

gear B

gear C

gear D

Bevel gear \_\_\_\_\_

Worm gear \_\_\_\_\_

2 marks

A frog is added to the water feature. The owner wants the frog to rotate.

- j. Design and draw on the diagram below (Figure 8) a **worm gear** system that would enable the frog to rotate. The direction of rotation is not important.

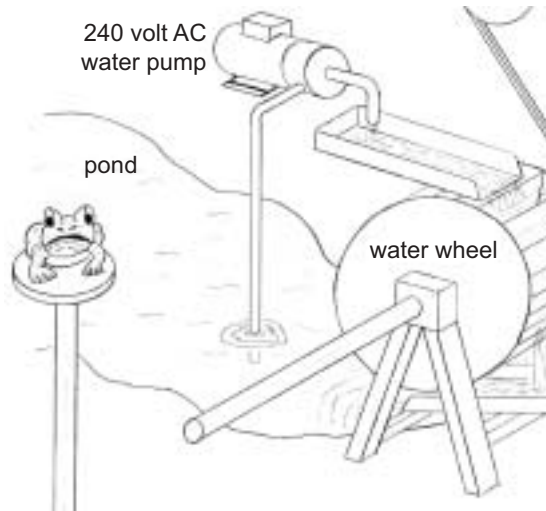

**Figure 8**

2 marks

- k. The drawing below (Figure 9) displays the frog and shaft only. Add a water wheel to Figure 9 that will drive the frog through a set of **bevel gears**. The direction of rotation is not important.



**Figure 9**

3 marks

Total 24 marks

**Question 5**

An electric motor operates the water pump. The owner decides to use 240 volts AC to power the motor.

- a. What do the initials AC stand for?

---

1 mark

- b. Sketch the waveform of a typical AC signal on the axes below. Clearly show **two** full AC cycles.



2 marks

The motor draws 40 mA of current.

- c. What does mA stand for?

---

1 mark

- d. Calculate how much power the motor uses. Refer to the formula on page 19 and show all working.

2 marks

- e. What is the resistance of the motor? Refer to the formula on page 19 and show all working.

2 marks

The owner of the water feature wants the electric pump to operate only when there is enough light and when there is enough water in the pond. This is to be done using a logic gate.

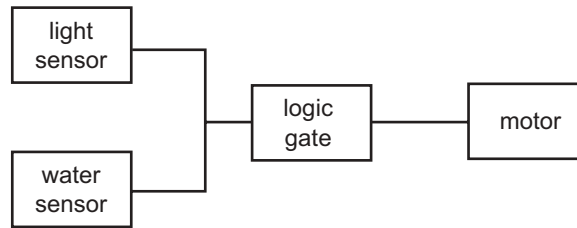

**Figure 10**

The logic gate must switch the motor on when **both** the light sensor and the water sensor have a logic output of 1.

f. Which type of logic gate would do this?

\_\_\_\_\_ 1 mark

g. Complete the truth table for this logic gate.

A	B	Output
0	0	
0	1	
1	0	
1	1	

2 marks

h. i. Is this an open loop or a closed loop system?

\_\_\_\_\_

ii. Explain why.

\_\_\_\_\_  
 \_\_\_\_\_

1 + 2 = 3 marks

The circuit diagram shown in Figure 11 provides the power to the water level indicator.

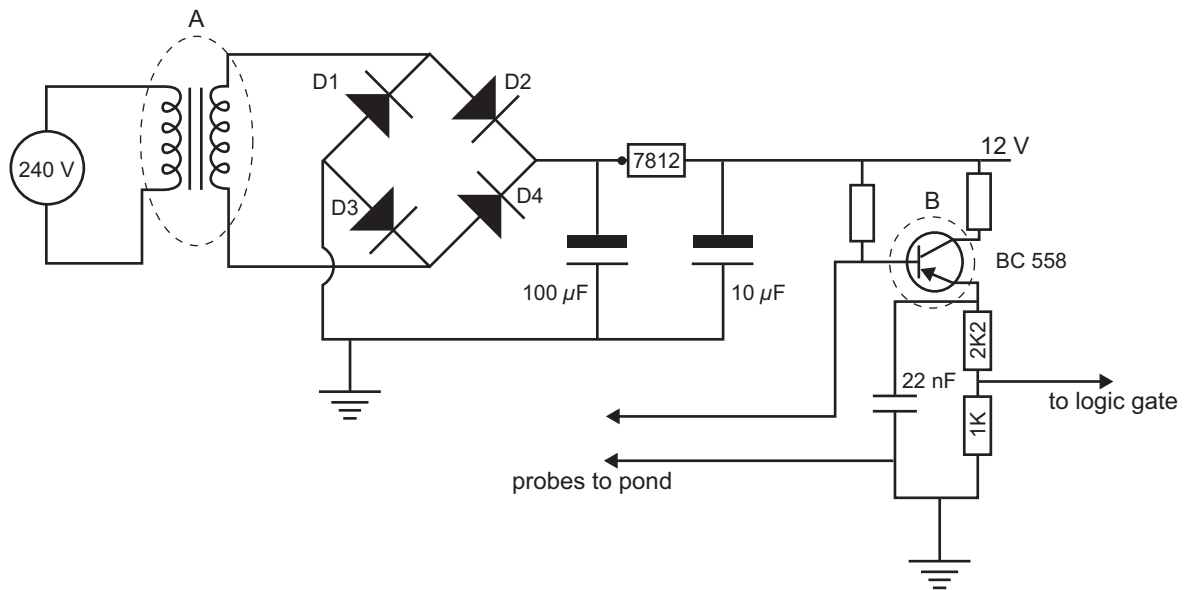

**Figure 11**

- i. Name the following components that have been marked in Figure 11.

A \_\_\_\_\_

B \_\_\_\_\_

2 marks

- j. In what units are resistors measured?

\_\_\_\_\_

1 mark

- k. In what units are capacitors measured?

\_\_\_\_\_

1 mark

- l. In electrical terms define rectification.

\_\_\_\_\_  
\_\_\_\_\_

1 mark

The diodes below provide the rectification in Figure 11. They are drawn differently here for easier understanding.

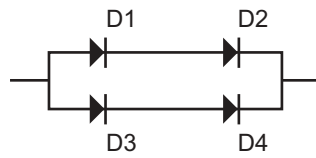

- m.** Name a pair of diodes that are connected in series.

---

1 mark

- n.** What type of connection do diodes D1, D2 with diodes D3, D4 form?

---

1 mark

Total 21 marks

**Question 6**

After the water feature system is set up, the owner suspects that one of the diodes in the electrical circuit is not functioning correctly.

- a. What is the basic function of a diode?

\_\_\_\_\_

1 mark

- b. Name an item of test equipment that could be used to test the function of a diode.

\_\_\_\_\_

1 mark

- c. Describe, in detail, how you would use this item of test equipment to test the diode for correct operation.

\_\_\_\_\_

\_\_\_\_\_

\_\_\_\_\_

2 marks

The water wheel system recycles the water used to turn the water wheel.

No system of recycling is ever 100% efficient. You decide that an efficiency rate of 95% is acceptable for the water wheel system.

- d. In percentage terms how much is the loss?

\_\_\_\_\_

1 mark

- e. If the input of the pump draws five litres of water per minute and allowing for an efficiency of 95%, how much of the water is lost every minute? Refer to formula on page 19 and show all workings.

2 marks

You want to set up a test to see if the water wheel meets this 95% efficiency rate.

- f. Name two items of test equipment that you could use to test this efficiency rating.

1. \_\_\_\_\_

2. \_\_\_\_\_

2 marks

- g. On the diagram below (Figure 12) mark with the letter **X** where you would place **one** item of the test equipment. Write the name of the item next to the letter X.

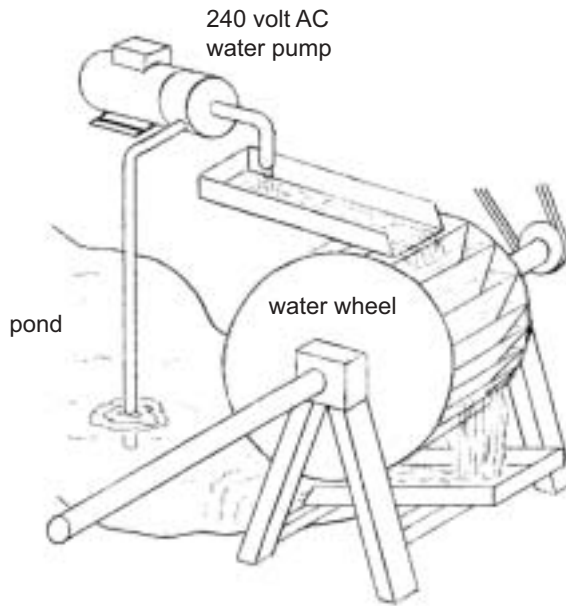

**Figure 12**

2 marks

Total 11 marks

**Question 7**

- a. The water wheel is tested and it is found to be 95% efficient in its use of water. Name two factors that would contribute to the loss of water when the water wheel is operating.

1. \_\_\_\_\_

2. \_\_\_\_\_

2 marks

The pump and recycling system could be replaced by a garden hose. The water from the hose could be used to turn the water wheel.

- b. Briefly explain a major environmental disadvantage of this system.

\_\_\_\_\_  
 \_\_\_\_\_

1 mark

- c. Briefly explain a major environmental disadvantage of using an electrical mains powered pump to run the system. Safety of the electrical mains is not an issue.

\_\_\_\_\_  
 \_\_\_\_\_

1 mark

Total 4 marks

**Formulas**

$$\frac{\text{Number of revolutions of pulley 1}}{\text{Number of revolutions of pulley 2}} = \frac{\text{Diameter of pulley 2}}{\text{Diameter of pulley 1}}$$

$$P = V \times I$$

$$V = I \times R$$

$$R = \frac{V}{I}$$

$$I = \frac{V}{R}$$

$$\text{Water loss} = \frac{\% \text{ loss}}{100} \times \frac{\text{Water flow}}{1}$$