



2006

Furnishing GA 2: Written examination

GENERAL COMMENTS

The 2006 VCE VET Furnishing written examination was the first under the National Training Package and reflected the seven competencies as described in the program booklet. A sample examination was produced and available to assist teachers and students. This reflected the changes to the examination but, as far as possible, the format and style remained consistent with previous years. The paper was well handled by the students who elected to sit the examination.

Areas of strength

- OH&S
- cutting lists
- cutting plans

Areas of weakness

- work plans – many students were not able to articulate the steps in making a work plan
- calculations – many students did not seem to understand simple calculations
- methods of work – some students showed an inability to explain how a process could be executed

SPECIFIC INFORMATION

Section A – Multiple-choice questions

Question	% A	% B	% C	% D	% No Answer
1	5	6	88	0	0
2	13	4	3	80	0
3	4	52	20	24	0
4	8	0	1	91	0
5	69	0	12	19	0
6	28	15	4	52	0
7	10	3	7	81	0
8	0	97	2	0	1
9	33	64	1	3	0
10	4	49	4	42	1
11	4	8	12	76	0
12	7	2	84	7	0
13	67	10	18	5	0
14	35	58	4	4	0
15	19	10	2	70	0
16	86	8	1	5	0
17	61	7	27	4	1
18	14	34	37	15	0
19	6	50	10	34	0
20	40	1	59	0	0

Section B – Short answer questions

Question 1

Marks	0	1	2	Average
%	1	22	77	1.8

Any two of:

- dust mask
- gloves
- ear muffs or ear plugs
- protective clothing.

2006 Assessment Report



Question 2

Marks	0	1	2	Average
%	5	19	76	1.7

Any two of:

- jig saw
- circular saw
- drop saw.

Question 3

Marks	0	1	Average
%	42	58	0.6

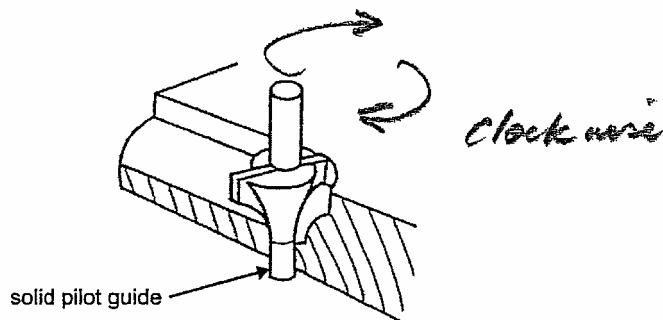

Question 4a.

Marks	0	1	Average
%	18	82	0.8

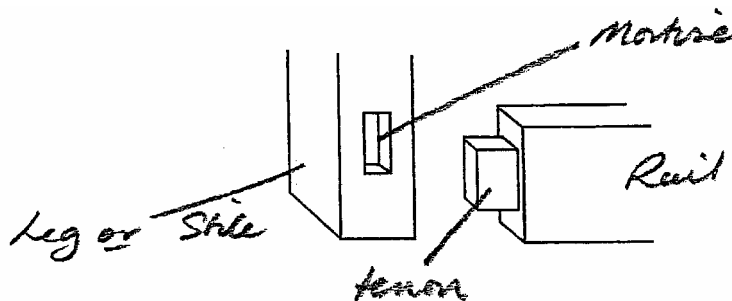

Question 4b.

Marks	0	1	Average
%	19	81	0.8

- window frames
- legs and rails of tables and chairs
- door stiles and rails

Question 5

Marks	0	1	2	3	Average
%	1	14	37	48	2.3

2006 Assessment Report

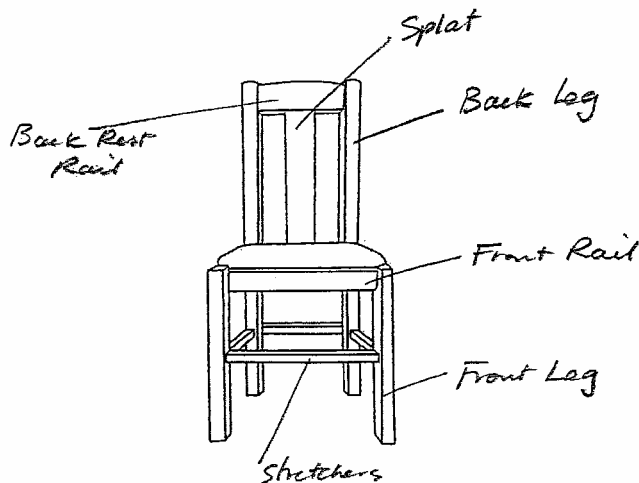

Question 6

Marks	0	1	2	3	Average
%	1	0	5	93	2.9

Task	Dowel or biscuit joint
joining legs and rails	dowel joint
joining timber that is less than 20 mm thick	biscuit joint
joining chair rails to back legs	dowel joint

Question 7a.

Marks	0	1	Average
%	9	91	0.9

- melamine-coated MDF
- melamine-coated particle board
- MDF – raw board
- veneered particle board
- pine

Question 7b.

Marks	0	1	2	3	Average
%	13	33	27	27	1.7

Reasons for the choice could have included any three of the following:

- there is a range of colours, wood grains, veneers or finishes
- the material suits the manufacturing process
- the material is cheaper than solid timber and more stable
- available in large sheets, a pre-finished product, stable, can be edged easily.

For full marks, students had to provide **three** reasons for their choice of material.

Question 8

Marks	0	1	2	Average
%	64	20	15	0.5

The rail needs to be drilled 36–37 mm to allow at least a 2 mm margin for glue and clearance factors so a flush joint can be achieved. The dowel should always be inserted into the shorter of the holes first to ensure maximum strength of the finished joint.

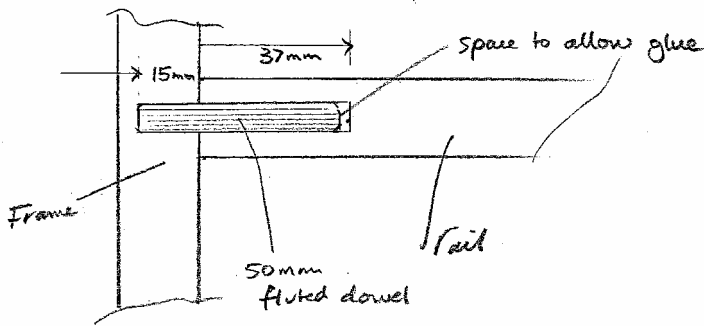

This question required students to recall correct methods of work such as leaving a 2 mm margin for glue and inserting the dowel into the shorter of the holes.

Question 9

Marks	0	1	2	3	Average
%	10	33	35	23	1.7

Type	Number
slotted head	1
phillips head	6
posidrive	3

Students needed to correctly identify the number for each type of screw to gain full marks. Some students found it difficult to correctly identify the posidrive.

Question 10a.

Marks	0	1	Average
%	0	100	1.0

Sanding block with abrasive paper

Question 10b.

Marks	0	1	2	3	Average
%	3	13	15	70	2.5

Method	Reason for use/not use
belt sander	This portable machine is too large and lacking in control to risk using for this process.
orbital/finishing sander	This is best used on a larger area. The paper is likely to break and/or cause damage to the rail.
sanding block with abrasive paper	This process has more control, and a variety of paper grits can be used to remove the scratch.

Question 11a.

Marks	0	1	2	3	Average
%	10	22	40	28	1.9

Any three of:

- hand-operated forklift
- forklift truck
- trolley (four wheel) with a suitably sized pallet
- hand trolley (two wheel)
- pallet truck
- metal sheet holders/grips used with gloves.

For full marks, students needed to correctly identify **three** types of appropriate manual handling equipment.

2006 Assessment Report



Question 11b.

Marks	0	1	Average
%	24	76	

Flammable goods cabinet

Question 11c.

Marks	0	1	Average
%	2	98	

Wear ear muffs

Question 11d.

Marks	0	1	Average
%	53	47	

That the hood guard is set as close as practicable to the material being cut; crown guard.

Students are encouraged to pay careful attention to the safety requirements of particular processes.

Question 11e.

Marks	0	1	Average
%	7	93	

A – the spray booth

Question 12

Marks	0	1	2	Average
%	7	36	57	

A tag should be attached and the supervisor and/or maintenance person notified. The machine should be sent away to be repaired by a suitably qualified person and retagged for use for the appropriate length of time.

Question 13

Marks	0	1	2	Average
%	3	20	78	

Any two of:

- wear PPE appropriate to the task
- do not place fingers near the blade when it is operating
- secure the work appropriately
- remove off cuts after switching off the machine
- do not cross arms, whether left or right handed.

For full marks, students needed to give **two** appropriate safety procedures.

Question 14

Marks	0	1	2	Average
%	4	16	80	

	Order (1–6)
glue rails and assemble legs and rails	4
dry test assembly of legs and rails	2
drill dowel holes in legs and rails	1
check for square	6
glue legs and insert dowels	3
clamp legs and rails	5



Question 15

Marks	0	1	2	3	4	5	6	7	8	Average
%	7	4	3	7	17	9	15	4	36	5.5

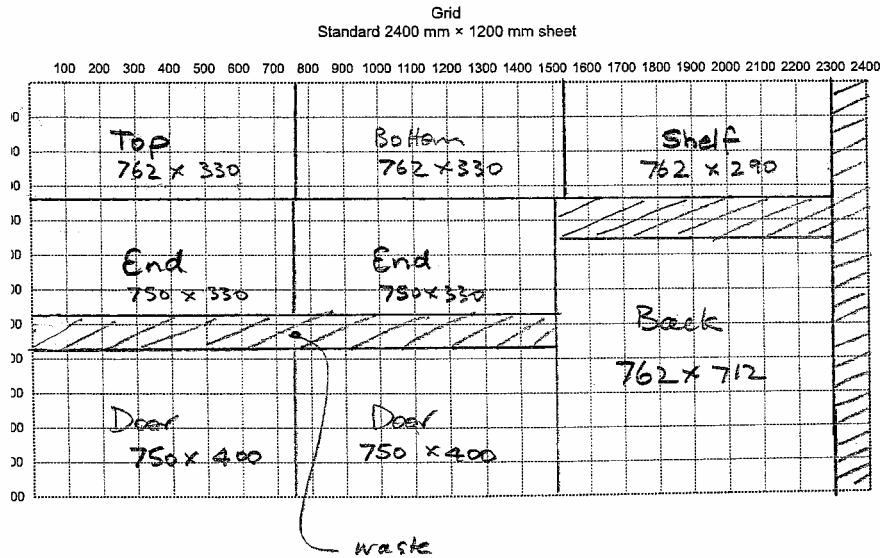

Students found some aspects of this question difficult. For example, setting out the components to be cut, naming each part from a list and entering the respective sizes.

Section C – Case Study

Question 1

Marks	0	1	2	3	4	5	6	7	8	9	10	Average
%	3	0	0	0	5	8	21	27	24	11	0	6.7

Item No.	Item	No. of pieces	Length	Width	Thickness	Material	Remarks
1	back leg	2	1000 ⁺	90 to pattern	45	Tasmanian Oak	leg to follow 32 mm parallel line to pattern and mitred at top on face
2	front leg	2	430	40	40	Tasmanian Oak	square dressed
3	front rail	1	330	50	22	Tasmanian Oak	square dressed
4	side rail	2	400	50	22	Tasmanian Oak	compound angle on rails
5	back seat rail	1	290	50	22	Tasmanian Oak	square dressed
6	seat	1	450	430	20	Tasmanian Oak	tapered to 390 at back to be made in 3 parts
7	top back rail	1	380	45	32	Tasmanian Oak	mitred at ends and dowelled to legs
8	ladder rail	3	290	45	22	Tasmanian Oak	dowelled to back legs

Students found some aspects of this question difficult. For example, interpreting information from specifications and inserting into the correct part of the cutting list.

Question 2

Marks	0	1	2	3	Average
%	50	20	18	12	1.0

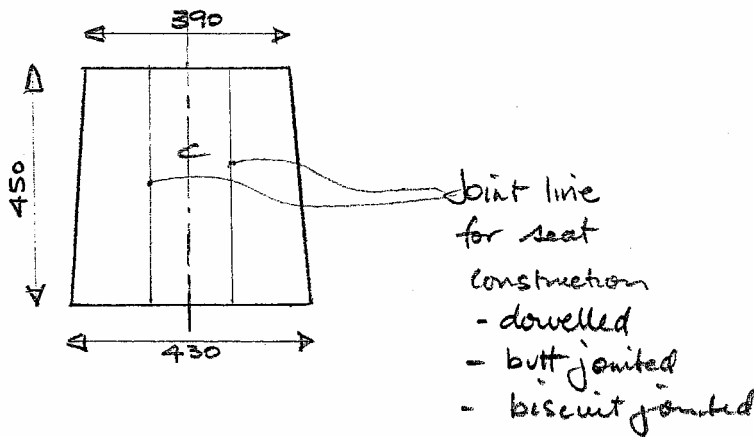

This question was particularly challenging for students. Many students were unable to show, either graphically or by simple explanation, how the seat of the chair would be constructed.

Question 3

Marks	0	1	2	Average
%	67	8	25	0.6

b. would be stronger as the leg has less 'short grain' and would be less likely to break/split.

For full marks, students were required to explain why their choice was appropriate.

Question 4

Marks	0	1	2	3	4	5	Average
%	60	5	7	3	3	22	1.6

$$12.57 \times 2.1 = 26.4$$

$$6.80 \times 0.9 = 6.12$$

$$6.40 \times 2.7 = 17.28$$

$$9.7 \times 1.5 = 14.55$$

$$26.4 + 6.12 + 17.28 + 14.55 = \$64.35$$

As this question involved money, all answers needed to be rounded off to two decimal places.

This question was challenging for students as it involved calculations. Students are encouraged to complete each step (showing their working) before recording their final answer.

Question 5

Marks	0	1	2	3	4	Average
%	8	27	32	22	11	2.0



Workplan

1.	Machine dress all materials for the chair as per the cutting list/full size set out.
2.	Mark out all components (legs, rails, seat components) and drill for dowels. Dry assemble components to check for accuracy.
3.	Glue, dowel, cramp up (a) back legs, rails (b) front legs and rail, (c) seat components. Check (a) and (b) for parallel, twist, wind, square.
4.	Glue, dowel, cramp up full chair, wipe off and clean up excess glue, check for twist, wind, parallel and square, prepare seat shape.
5.	Drill holes for chair seat, attach chair seat using screws, fit corner blocks for strength and counter sink screw holes to enable screws to sit flush with underside of rails.
6.	Sand all surfaces so that dents, scratches or machine marks are removed. The chair is now ready for polishing.

Many students found it difficult to put the steps of the process in the correct order, in particular, steps 3 and 5. Students are encouraged to consider all aspects of the task.

Question 6

Marks	0	1	2	3	4	5	6	Average
%	5	1	12	16	21	9	37	4.2

Hand tool	How tool is used
1. spoke shave	Used to clean up the back leg of the chair prior to sanding, helps to remove bandsaw marks.
2. hand plane (smoothing)	Used to remove machine marks, flush off joints, removes arrises on all chair components.
3. sanding cork	Used in conjunction with abrasive paper to sand all components of the chair prior to assembly and a general clean up after, prior to the polishing process.

Other hand tools employed in the construction of the chair include: marking gauge, try square, steel rule, tape measure, sash cramps, screwdriver, chisels and/or tenon to cut mortise and tenon joints as applicable, mallet, claw hammer, pencil to mark out face and face edge marks.

Question 7

Marks	0	1	2	3	Average
%	23	32	33	13	1.4

- Delete three ladder back rails. Make a pattern to shape that matches the leg shape for the vertical slats. Decide on dowel or mortise and tenon joint.
- Delete the chair seat and replace with a frame to be upholstered. Add corner blocks to strengthen chair frame. Decide on a method to fix the seat.
- Add or move position of back seat rail to enable the vertical slats to be housed adequately.

Including any three of the above points was awarded full marks.