



**Victorian Certificate of Education
2007**

SUPERVISOR TO ATTACH PROCESSING LABEL HERE

STUDENT NUMBER

Figures

Words

Letter

--

PHYSICS

Written examination 2

Wednesday 14 November 2007

Reading time: 11.45 am to 12.00 noon (15 minutes)

Writing time: 12.00 noon to 1.30 pm (1 hour 30 minutes)

QUESTION AND ANSWER BOOK

Structure of book

<i>Section</i>	<i>Number of questions</i>	<i>Number of questions to be answered</i>	<i>Number of marks</i>
A – Core – Areas of study			
1. Electric power	15	15	40
2. Interactions of light and matter	11	11	25
B – Detailed studies			
1. Synchrotron and its applications	11	11	25
OR			
2. Photonics	11	11	25
OR			
3. Sound	11	11	25
			Total 90

- Students are permitted to bring into the examination room: pens, pencils, highlighters, erasers, sharpeners, rulers, up to two pages (one A4 sheet) of pre-written notes (typed or handwritten) and one scientific calculator.
- Students are NOT permitted to bring into the examination room: blank sheets of paper and/or white out liquid/tape.

Materials supplied

- Question and answer book of 36 pages, with a detachable data sheet in the centrefold.

Instructions

- Detach the data sheet from the centre of this book during reading time.
- Write your **student number** in the space provided above on this page.
- Answer all questions in the spaces provided.
- **Always** show your working where space is provided because marks may be awarded for this working.
- All written responses must be in English.

Students are NOT permitted to bring mobile phones and/or any other unauthorised electronic devices into the examination room.

SECTION A – Core**Instructions for Section A**

Answer **all** questions **for both** Areas of study in this section of the paper.

Area of study 1 – Electric power**Question 1**

Figure 1 shows a bar magnet.

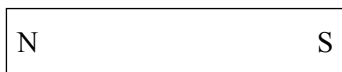
**Figure 1**

Complete the diagram by sketching five magnetic field lines around the magnet. You must include arrows which show the direction of the magnetic field of the magnet.

2 marks

Question 2

A second bar magnet is placed next to the original as shown in Figure 2.

**Figure 2**

Complete the diagram by sketching magnetic field lines to indicate the shape of the magnetic field around the magnets.

2 marks

Question 3

Figure 3 shows a power line at a mining site that carries a DC current of 2000 A running from west to east. The earth's magnetic field at the mining site is 4.0×10^{-5} T, running horizontally from south to north. An engineer is concerned about the electromagnetic force due to the earth's magnetic field on the wire between the two support poles, which are 20 m apart.

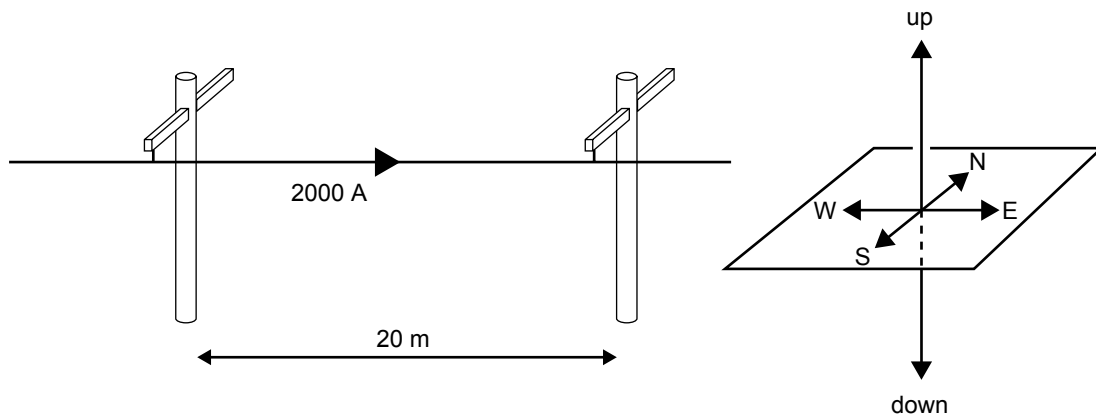
**Figure 3**

Calculate the magnitude and direction (north, south, east, west, up, down) of the force due to the earth's magnetic field on the 20 m section of wire between the two poles.

magnitude	N	direction
-----------	---	-----------

3 marks

Use the following information to answer Questions 4 and 5.

Figure 4 shows a schematic diagram of a DC motor.

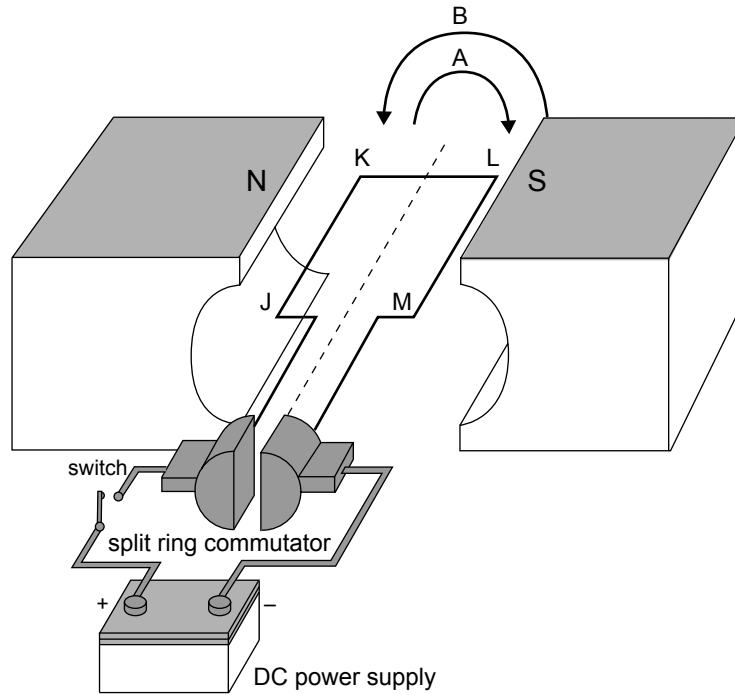

Figure 4

Question 4

The motor is initially stationary as shown in Figure 4.

- a. In which direction, A (clockwise) or B (anticlockwise), will the motor rotate when the switch is closed?

- b. Explain your answer.

1 + 2 = 3 marks

Question 5

Why is the split ring commutator necessary for the motor to operate correctly? Explain the operation of the commutator.

3 marks

Use the following information to answer Questions 6 and 7.

Figure 5 shows an alternator consisting of a rectangular coil with sides of $0.20\text{ m} \times 0.30\text{ m}$, and 1000 turns rotating in a uniform magnetic field. The magnetic flux through the coil in the position shown is $3.0 \times 10^{-4}\text{ Wb}$.

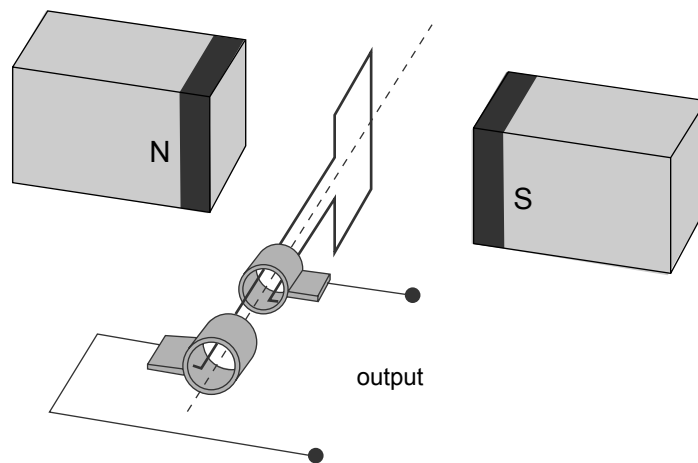

Figure 5

Question 6

What is the magnitude of the magnetic field? Include a unit.

magnitude	unit

3 marks

Question 7

The coil rotates a quarter of a revolution in 0.01 s from the starting position shown in Figure 5.

Calculate the magnitude of the average induced emf in the coil in this time.

You must show your working.

	V
--	---

3 marks

Use the following information to answer Questions 8 and 9.

At a particular speed of rotation, the output of another alternator is as shown in Figure 6 below.

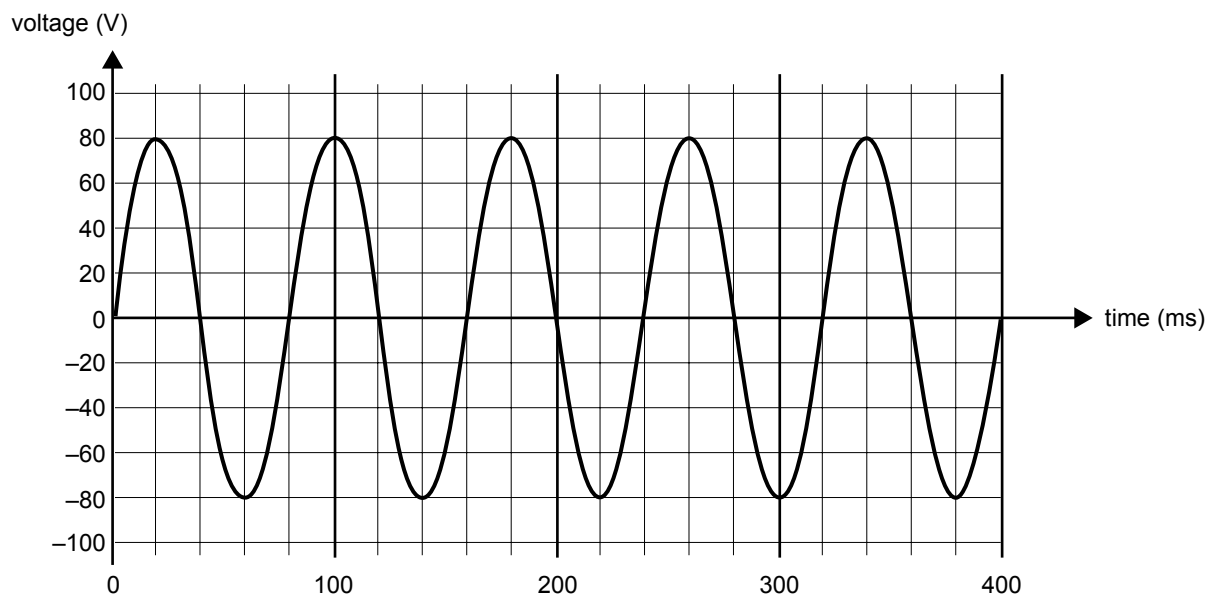

Figure 6

Question 8

What is the frequency of rotation of the alternator?

 Hz

3 marks

Question 9

What is the RMS value of the output voltage?

 V

2 marks

Question 10

Another alternator is driven by a water turbine, as shown in Figure 7.

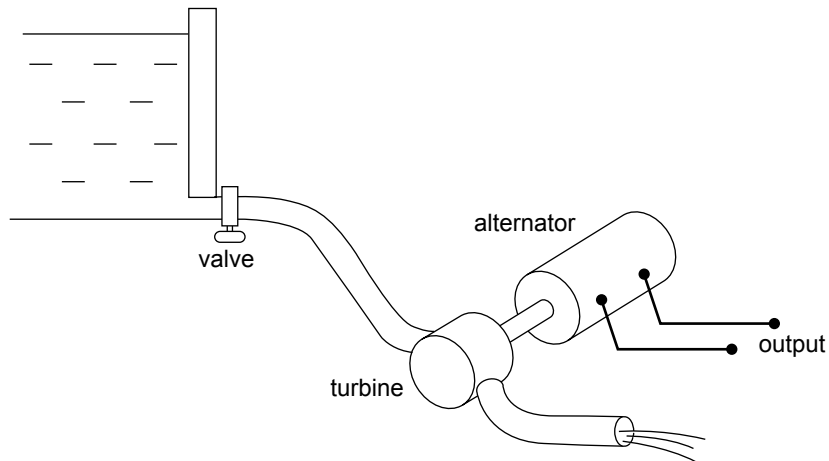
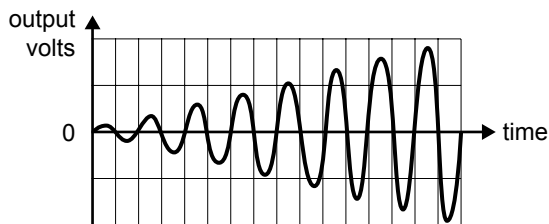

Figure 7

When the valve is opened, water begins to flow and the alternator gradually speeds up from stationary. Which one of the following graphs (A–D) best represents the shape of the output voltage as the alternator speeds up from rest?

A.



B.

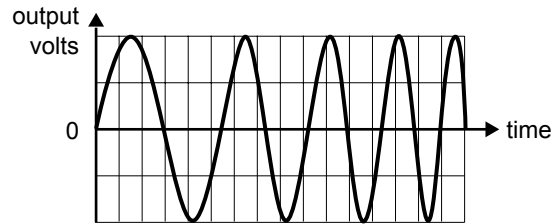

C.

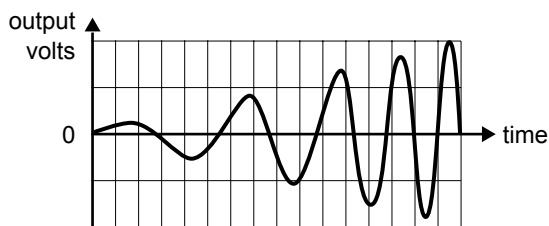

D.

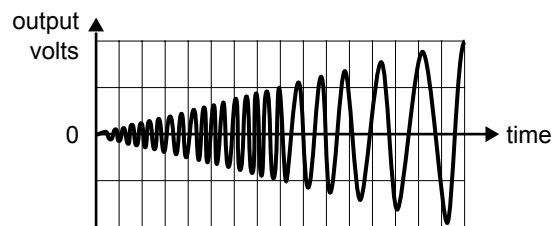

2 marks

Use the following information to answer Questions 11–13.

A class of physics students builds a model of an electricity distribution system. The circuit diagram of the model is shown in Figure 8. Ignore the resistance of wires connecting the power supply, transformer and globe to the transmission lines.

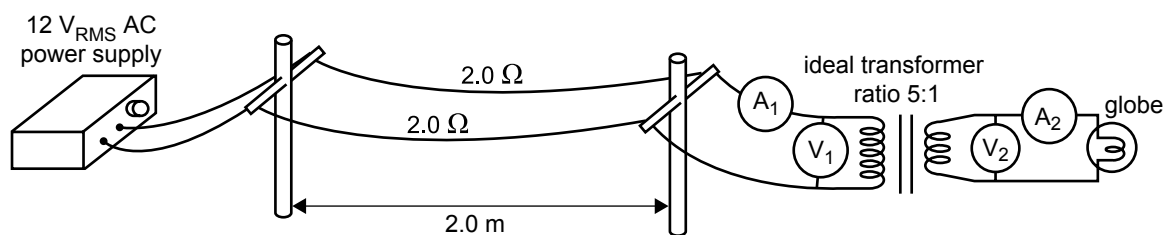

Figure 8

Assume that the transformer acts as an ideal transformer (no energy losses in transformer) of ratio primary to secondary windings of 5:1.

The current through ammeter A_1 is 0.50 A.

Question 11

What would be the reading on each of the meters A_2 , V_1 and V_2 ?

i.	A_2	<input type="text"/>	A
ii.	V_1	<input type="text"/>	V
iii.	V_2	<input type="text"/>	V

3 marks

Question 12

What would be the power delivered at each of the points listed below?

i.	At the output of the $12 V_{\text{RMS}}$ power supply	<input type="text"/>	W
ii.	At the input to the primary coil of the transformer	<input type="text"/>	W
iii.	At the globe	<input type="text"/>	W

3 marks

Question 13

The $12 \text{ V}_{\text{RMS}}$ AC power supply is replaced by a 12 V battery.

What will be observed at the globe shown in Figure 8?

Explain this observation in terms of the operation of a transformer.

3 marks

Use the following information to answer Questions 14 and 15.

To study Lenz's law, students set up the following experiment using the circuit shown in Figure 9.

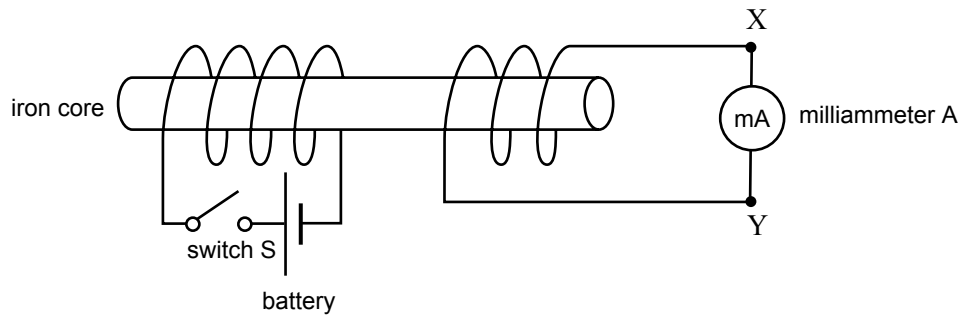

Figure 9

Question 14

Initially switch S is open.

Which one of the following (A–D) will best describe the current through the milliammeter A, when the switch S is closed?

- A. current flows momentarily in the direction X to Y
- B. current flows momentarily in the direction Y to X
- C. current flows continuously in the direction X to Y
- D. current flows continuously in the direction Y to X

2 marks

Question 15

Explain how Lenz's law enables you to determine the direction of the current flow in this experiment.

3 marks

Area of study 2 – Interactions of light and matter

Use the following information to answer Questions 1–3.

Some students are investigating the photoelectric effect. They shine light of different wavelengths onto a rubidium plate. They measure the maximum kinetic energy of photoelectrons emitted from the plate. Their data of maximum kinetic energy of ejected photoelectrons as a function of the frequency of incident light is shown in Figure 1.

In answering the following questions, you must use the data from the graph.

Take the speed of light to be $3.0 \times 10^8 \text{ m s}^{-1}$

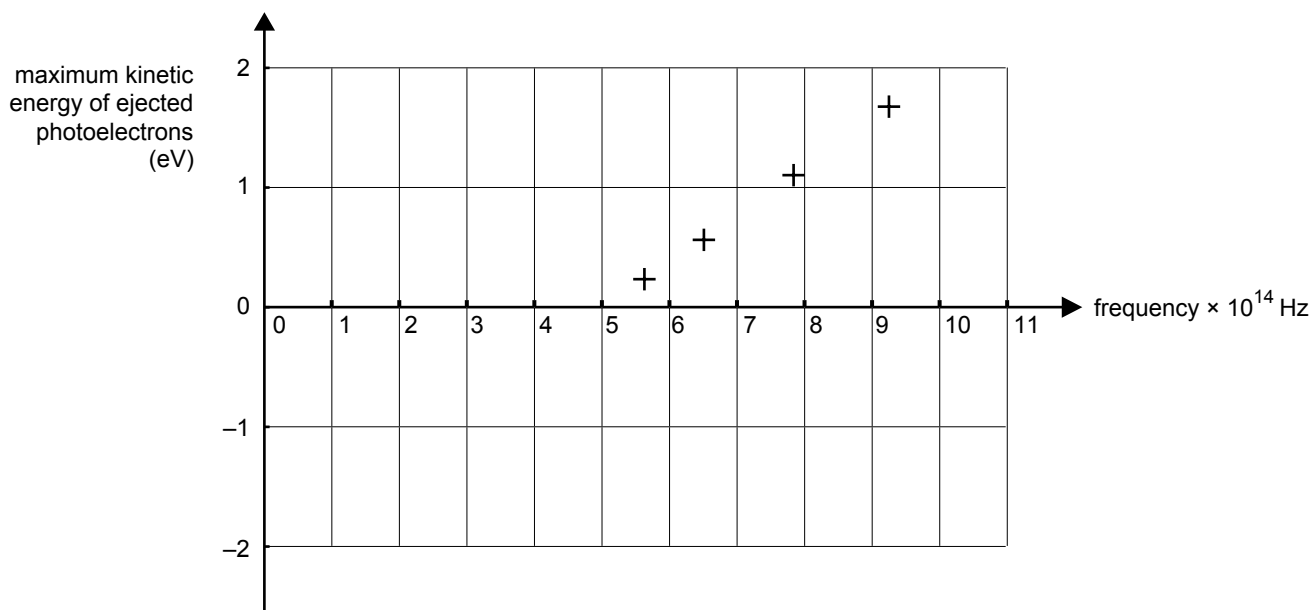

Figure 1

Question 1

From the data on the graph, what is the minimum energy, W , required to remove photoelectrons from the rubidium plate?

 eV

2 marks

The students shine light of wavelength $\lambda = 400 \text{ nm}$ onto the rubidium plate.

Question 2

From the graph, with what maximum kinetic energy would the photoelectrons be emitted?

 eV

2 marks

Question 3

The students use a light source that emits a large range of frequencies. They use filters which allow only certain frequencies from the source to shine onto the plate. Most of the students' filters produce frequencies below the cut-off frequency. Alice says that if they increase the intensity of light, these frequencies below the cut-off frequency will be able to produce emitted photoelectrons.

They experiment and find Alice is incorrect. Comment whether this experimental evidence supports the wave-like or the particle-like theory of light.

3 marks

Use the following information to answer Questions 4 and 5.

Neutrons are subatomic particles and, like electrons, can exhibit both particle-like and wave-like behaviour.

A nuclear reactor can be used to produce a beam of neutrons, which can then be used in experiments.

The neutron has a mass of 1.67×10^{-27} kg.

The neutrons have a de Broglie wavelength of 2.0×10^{-10} m.

Question 4

Calculate the speed of the neutrons.

m s^{-1}

2 marks

Question 5

The neutron beam is projected onto a metal crystal with interatomic spacing of 3.0×10^{-10} m.

Would you expect to observe a diffraction pattern? Explain your answer.

2 marks

In an experiment, monochromatic laser light of wavelength 600 nm shines through a narrow slit, and the intensity of the transmitted light is recorded on the screen some distance away as shown in Figure 2a. The intensity pattern seen on the screen is shown in Figure 2b.

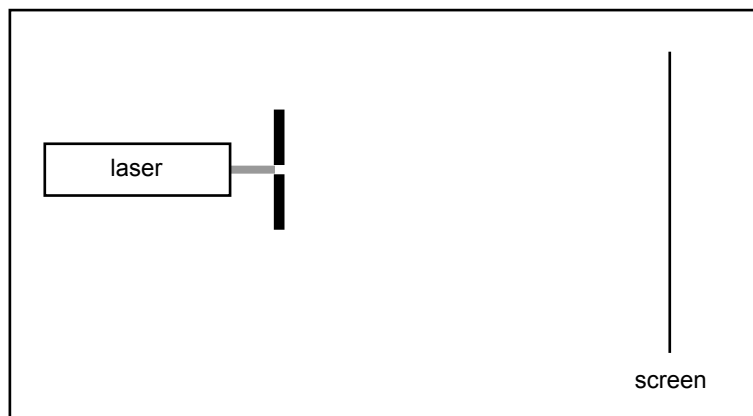

Figure 2a

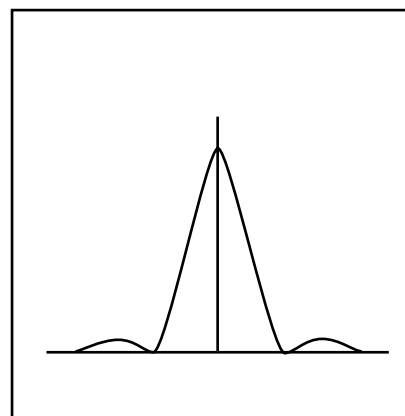
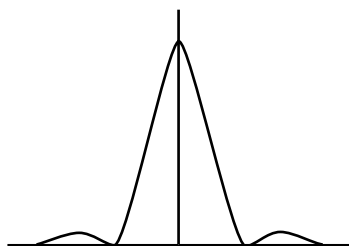

Figure 2b

Question 6

Which one of the intensity patterns (A–D) below best indicates the pattern that would be seen if a wider slit was used?

A.



B.

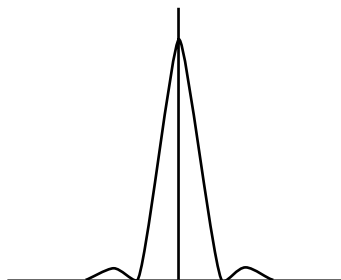

C.

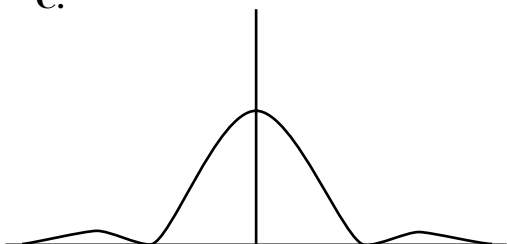

D.

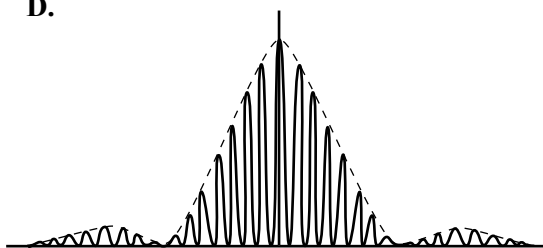

2 marks

Use the following information to answer Questions 7 and 8.

Part of the visible region of the spectrum of light emitted from excited hydrogen gas has three lines as shown in Figure 3.

The energy level diagram for the hydrogen atom is shown in Figure 4. The binding energy is 13.6 eV.

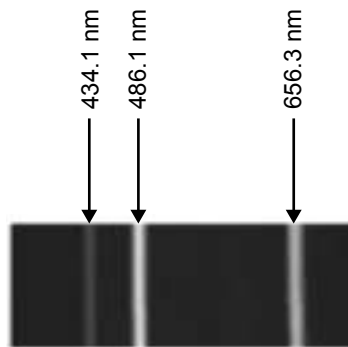

Figure 3

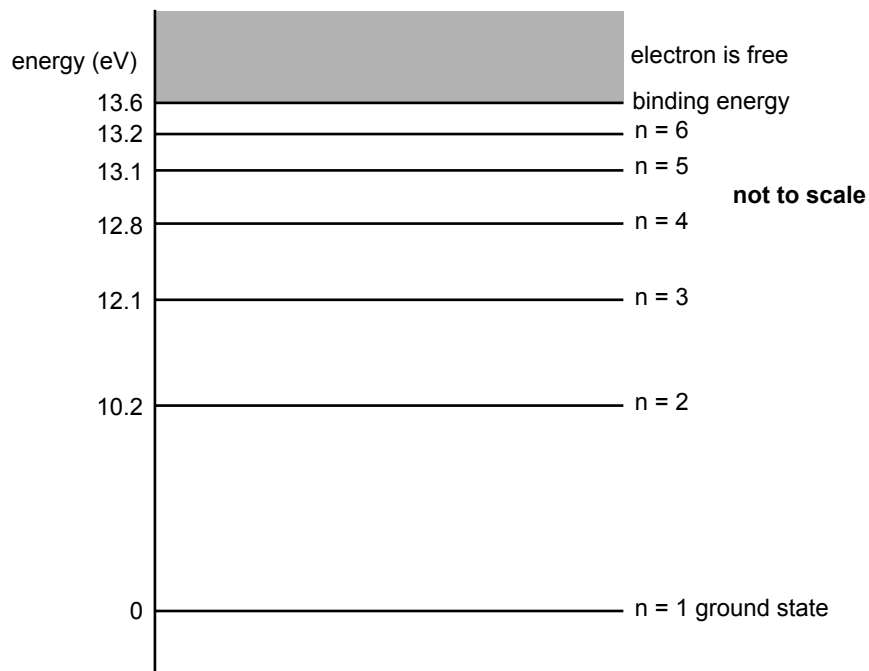

Figure 4

Question 7

What is the energy of the photons with a wavelength 434.1 nm in Figure 3?

eV

3 marks

Question 8

A different photon has an energy of 3.0 eV.

On Figure 4 (page 16), indicate with an arrow the electron transition that leads to emission of a photon of light with this energy.

2 marks

Figure 5a shows part of the emission spectrum of hydrogen in more detail.

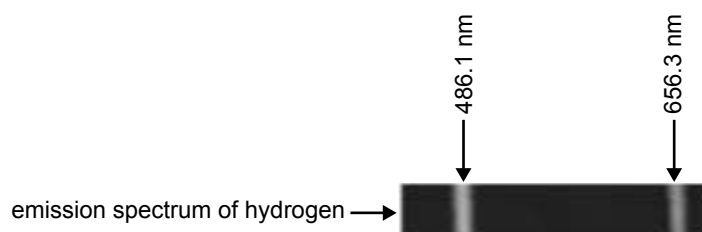
**Figure 5a**

With a spectroscope, Val examines the spectrum of light from the sun. The spectrum is continuous, with colours ranging from red to violet. However there were black lines in the spectrum, as shown in Figure 5b.

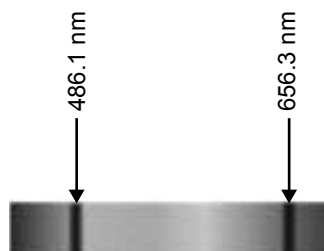
**Figure 5b****Question 9**

Explain why these dark lines are present in the spectrum from the sun.

3 marks

Use the following information to answer Questions 10 and 11.

A class looks at spectra from two sources.

- i. an incandescent light globe
- ii. a mercury vapour lamp

They observe that the spectra are of different types.

Question 10

In the spaces below, state the type of spectrum seen from each source.

- i. Incandescent light globe

- ii. Mercury vapour lamp

2 marks

Question 11

State the electron mechanism, in each of the sources below, that produces each spectrum.

- i. Incandescent light globe

- ii. Mercury vapour lamp

2 marks

SECTION B – Detailed studies**Instructions for Section B**

Choose **one** of the following **Detailed studies**. Answer **all** the questions on the Detailed study you have chosen.

Detailed study 1 – Synchrotron and its applications**Question 1**

In the paragraph below, options to complete each sentence are given within the brackets. Circle the correct option in each case.

The booster ring of a synchrotron

[**gives the initial boost to stationary electrons / accelerates electrons from the linac /**

stores electrons until needed in a beam line].

Synchrotron radiation emerges as the electrons in the storage ring

[**pass from the storage ring into a beam line / travel around curved segments /**

travel at constant speed along straight segments].

Energy lost by the electrons to synchrotron radiation is replenished by

[**diverting the electrons through the booster ring / electric fields in the straight segments /**

the bending magnets in circular sections].

3 marks

Question 2

Figure 1 shows a simple electron gun used to inject electrons into the linac of a synchrotron. The accelerating voltage is 2000 V.

Mass of electron = 9.11×10^{-31} kg

Charge on electron = -1.60×10^{-19} C

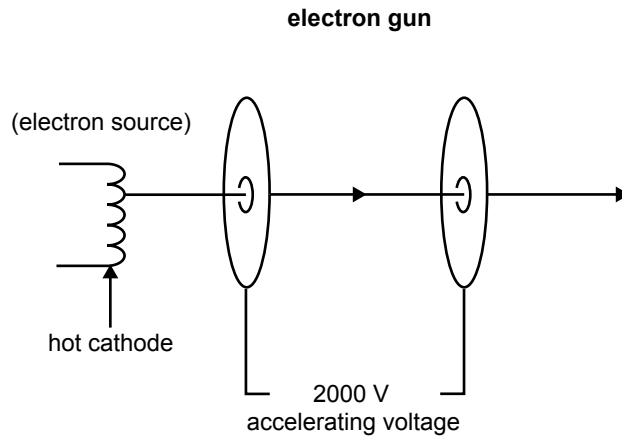

Figure 1

At what speed do the electrons emerge from the electron gun? (Ignore relativistic effects.)

m s^{-1}

2 marks

Use the following information to answer Questions 3 and 4.

A magnet called an injection magnet of magnetic field strength $1.2 \times 10^{-4} \text{ T}$ bends a pulse of electrons emitted from the linac so that they enter the circular booster ring as shown in Figure 2.

The electrons emerge from the linac with a speed of $5.0 \times 10^6 \text{ m s}^{-1}$.

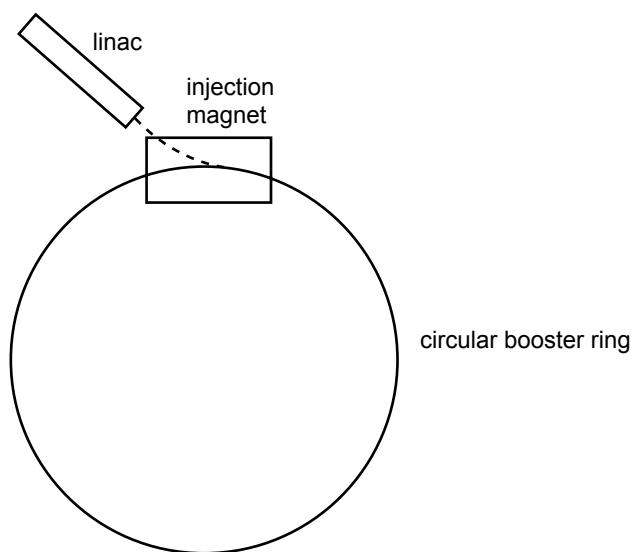

Figure 2

Question 3

What is the magnitude of the radius of the trajectory of the electrons from the linac as they pass through the injection magnet?

 m

2 marks

Question 4

In normal operation, the injection magnet switches on only for the brief instant necessary to direct the pulse of electrons into the circular booster ring.

However, due to a malfunction, the magnet was still on after the pulse of electrons had completed one revolution of the circular booster ring. The electrons now pass through the magnet a second time.

Which one of the following (A–D) would occur?

- A. The electrons would continue around the ring.
- B. The electrons would be deflected outwards from the ring.
- C. The electrons would be deflected inwards from the ring.
- D. The electrons would lose energy and continue around the circular booster ring at a lower speed.

2 marks

Question 5

In a synchrotron, an electron which is travelling at 2500 m s^{-1} moves from a linear region into a magnetic field of 0.50 T as shown in Figure 3.

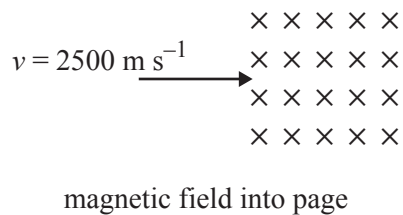
**Figure 3**

What will be the magnitude and direction (into page, out of page, up page, down page) of the force on the electron?

magnitude	N	direction
-----------	---	-----------

3 marks

Question 6

In a typical synchrotron experiment to study a sample of material, which one of the following (A–D) passes along a beam line?

- A. a beam of energetic electrons
- B. a strong magnetic field
- C. a beam of electromagnetic radiation
- D. a beam of laser light

2 marks

Question 7

X-rays of wavelength 0.120 nm travel along a synchrotron beam line onto a sample of crystalline material. What is the energy, in keV, of these X-rays?

2 marks

Question 8

These X-rays impact on a crystal, and the first maximum of the Bragg diffraction pattern is observed at 17.5° to the plane of the atoms in the crystal.

What is the spacing between the planes of atoms in the crystal?

2 marks

Question 9

At which one of the following pairs of angles (A–D) would Bragg diffraction also be observed?

- A. 5.8° and 8.8°
- B. 30.5° and 61.0°
- C. 35.0° and 52.5°
- D. 37.0° and 64.4°

2 marks

Question 10

Incident X-rays are scattered from a sample of material by inelastic (Compton) scattering.

Which one of the following statements (**A–D**) best describes the scattered X-rays?

- A.** The scattered X-rays have the same energy as the incident X-rays.
- B.** The scattered X-rays have a shorter wavelength than the incident X-rays.
- C.** The scattered X-rays have the same wavelength as the incident X-rays.
- D.** The scattered X-rays have a longer wavelength than the incident X-rays.

2 marks

Question 11

Bragg diffraction can be used in a synchrotron to tune the wavelength of the beam line.

Explain how this is achieved.

3 marks

Detailed study 2 – Photonics

Question 1

In the paragraph below, options to complete each sentence are given within the brackets. Circle the correct option in each case.

A particular laser operates by using a voltage to initially excite atoms into a higher (stable) energy state. This process is known as

[**stimulated emission** / **population inversion** / **constructive interference**].

The excited atoms are then stimulated to de-excite by emitting [**X-rays** / **electrons** / **photons**] by interacting with a photon of [**lower** / **the same** / **higher**] energy than the elevated electron energy level.

3 marks

Use the following information to answer Questions 2–4.

Chris is testing LEDs (Light Emitting Diodes).

She has a LED which emits blue light (blue LED) and another which emits red light (red LED).

Blue light has a higher frequency than red light.

She uses the circuit shown in Figure 1.

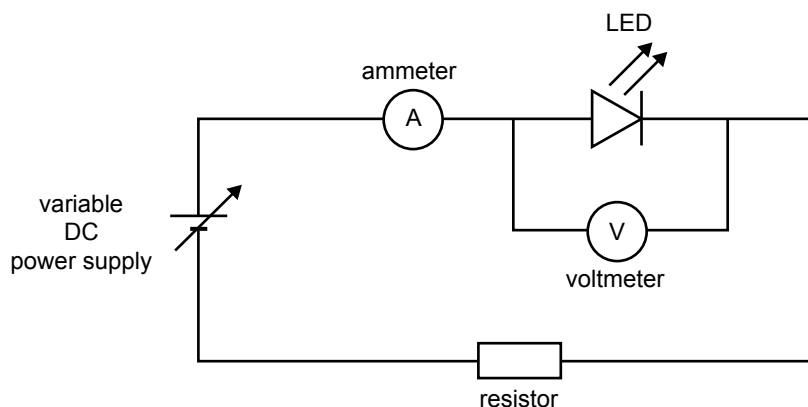

Figure 1

With the blue LED in the circuit the supply voltage is gradually increased. The LED does not emit light until the voltage reading on the voltmeter is 2.64 V. At this time there is a current of 5.00 mA read on the ammeter, A.

Question 2

Explain why the blue LED needs 2.64 V to emit light.

2 marks

Question 3

Assuming an ideal diode, calculate the wavelength of the blue light emitted by the blue LED.

nm

3 marks

Question 4

The blue LED is now replaced with the red LED. The supply voltage is left unchanged. Which one of the following sets of observations (**A–D**) will now describe the situation?

	Red LED	Voltage across LED	Current through A
A.	Light emitted	Less than 2.64 V	Greater than 5.00 mA
B.	Light emitted	Greater than 2.64 V	Less than 5.00 mA
C.	No light emitted	Less than 2.64 V	Greater than 5.00 mA
D.	No light emitted	Greater than 2.64 V	Less than 5.00 mA

2 marks

Use the following information to answer Questions 5 and 6.

Figure 2 below shows a ray of light entering from air ($n_{\text{air}} = 1.00$) into a step index fibre which has $n_{\text{core}} = 1.46$ and $n_{\text{cladding}} = 1.43$. The ray is incident on the core-cladding interface at the critical angle for total internal reflection, i_c . ($n =$ refractive index)

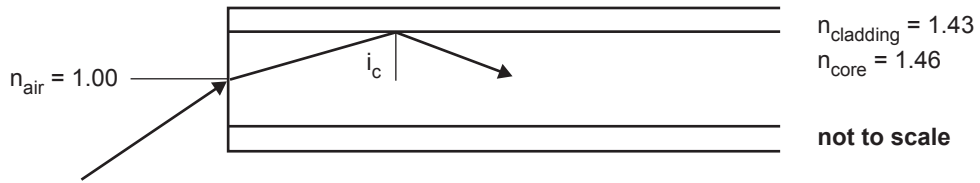

Figure 2

Question 5

The best estimate of i_c is

- A. 12°
- B. 43°
- C. 47°
- D. 78°

2 marks

For a **different** step index fibre, the refractive index of the core is 1.46 and the refractive index of the cladding is 1.37. The critical angle, i_c , is 70° . This is shown in Figure 3 below.

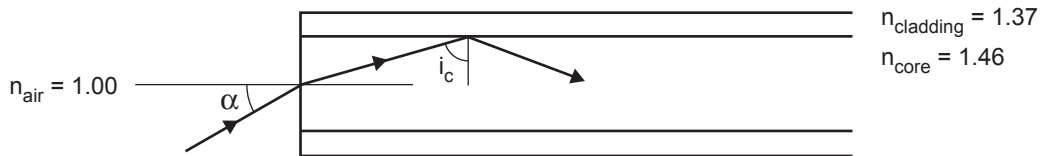

Figure 3

Question 6

The best estimate of the acceptance angle, α , is

- A. 20°
- B. 30°
- C. 47°
- D. 70°

2 marks

Use the following information to answer Questions 7 and 8.

A LED, a single mode step index fibre, and a phototransistor are used in a telecommunications system. The LED emits light in the wavelength range of 840–880 nm. To test the system a pulse is transmitted as shown in Figure 4 below.

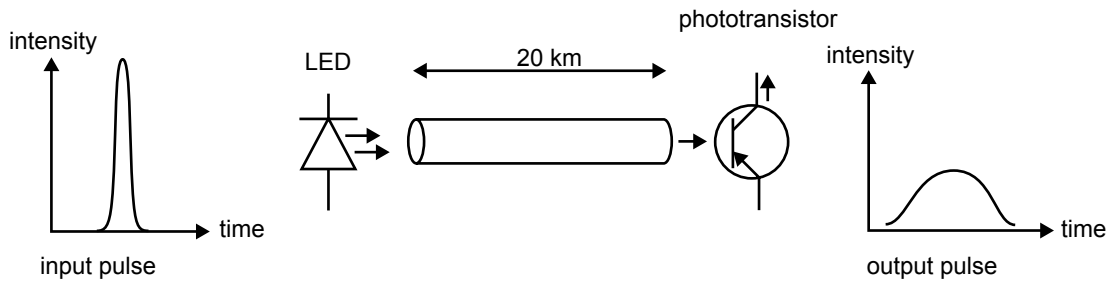

Figure 4

Question 7

The output pulse has suffered significant material dispersion as shown. Explain why material dispersion occurs in the system.

2 marks

Question 8

Clare suggests that the effect of material dispersion can be reduced by using a laser in place of the LED. Explain why this will reduce the effect of material dispersion on the pulse.

2 marks

Use the following information to answer Questions 9 and 10.

The graph in Figure 5 shows the attenuation (optical loss) versus wavelength for a particular material used to make optical fibres.

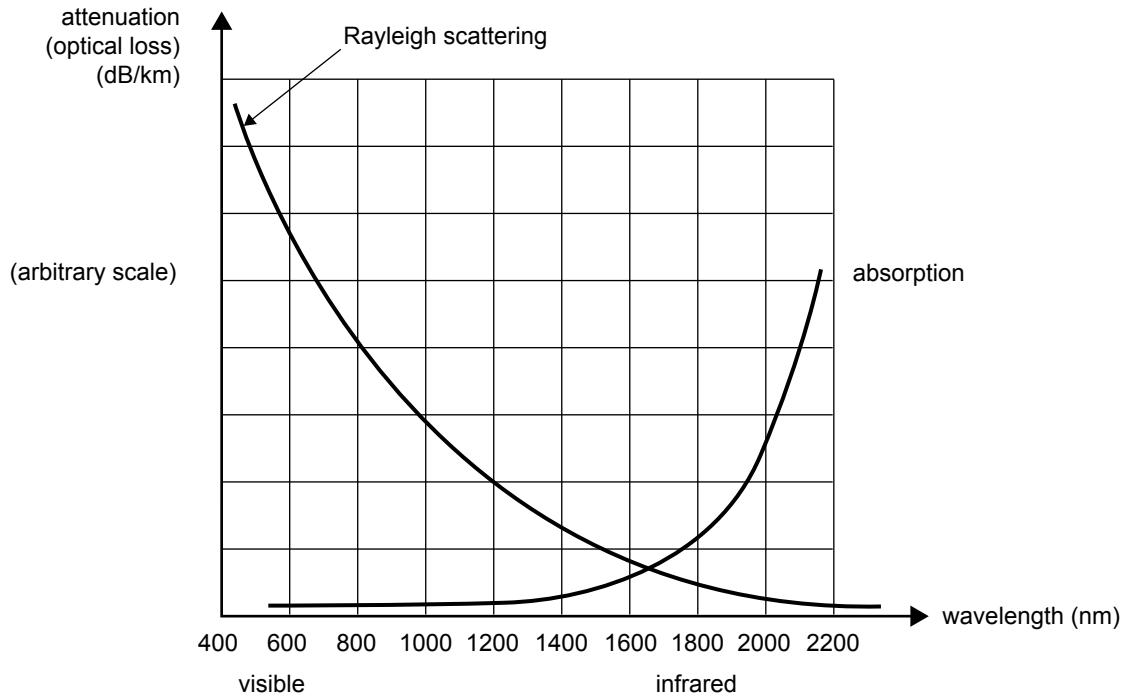

Figure 5

Two lasers are used: a red (visible) laser of wavelength 640 nm, and an infrared laser of wavelength 1700 nm.

Question 9

Which one of the following causes (A–D) would produce the major attenuation for the red laser?

- A. modal dispersion
- B. material dispersion
- C. Rayleigh scattering
- D. absorption by the material

2 marks

Question 10

In terms of attenuation, explain which of the two lasers would be best for use in a fibre optic system made from this material. You should refer to the information on the graph (Figure 5).

2 marks

Question 11

A single mode, step index optical fibre is to be used as a simple, intensity-based sensor to detect excessive bending in a concrete beam in a bridge.

The fibre is embedded in the concrete in a winding pattern as shown in Figure 6, with the light path impacting on the core-cladding interface just below the critical angle on the most curved section of the fibre within the beam.

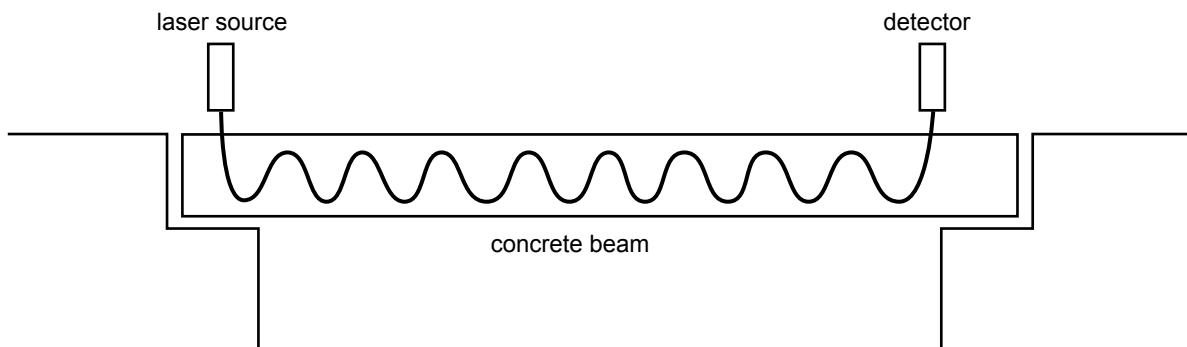
**Figure 6**

Explain what will be observed at the detector if the beam bends, and hence how the fibre operates as a simple intensity-based sensor.

Detailed study 3 – Sound

Take speed of sound in air as 340 m s^{-1}

Question 1

In the paragraph below, options to complete each sentence are given within the brackets. Circle the correct option in each case.

A loudspeaker is removed from its enclosure box. When an audio signal is connected, the loudspeaker produces sound waves at both its front and rear surfaces. The sound waves from the front of the loudspeaker are [**in phase with / out of phase with / of much higher intensity than**] the waves from the rear. For a listener in front of the speaker the waves from the front [**interfere constructively / interfere destructively / diffract destructively**] with those generated from the rear surface. This affects the [**frequency / intensity / directional spread**] of the resulting sound.

3 marks

Use the following information to answer Questions 2–5.

In order to study resonance in air columns, students use a narrow tube of length 0.50 m that is closed at one end and open at the other. They use a signal generator and loudspeaker as shown in Figure 1.

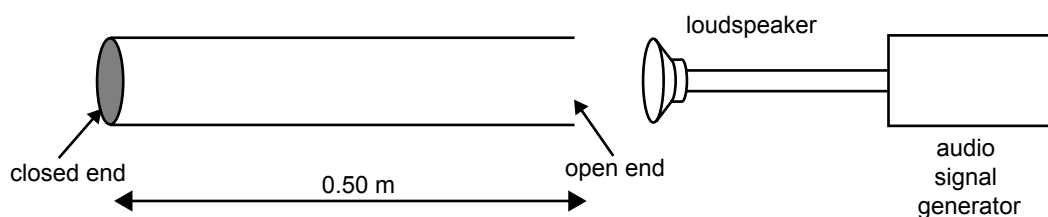

Figure 1

The students begin the experiment by using a sound of frequency 100 Hz.

Question 2

What is the wavelength of the sound?

m

2 marks

The students increase the frequency until the first resonance (first harmonic) is reached.

Question 3

At what frequency will this occur?

Hz

2 marks

Question 4

What will the students hear that will enable them to identify this resonance frequency?

Explain why this occurs.

2 marks

Question 5

As they increase the frequency above the first resonance, at what frequency (**A–D**) will they hear the next resonance?

- A. 85 Hz
- B. 170 Hz
- C. 340 Hz
- D. 510 Hz

--

2 marks

Question 6

Explain the operation of a dynamic microphone.

2 marks

Figure 2 shows the frequency response curve for a dynamic microphone.

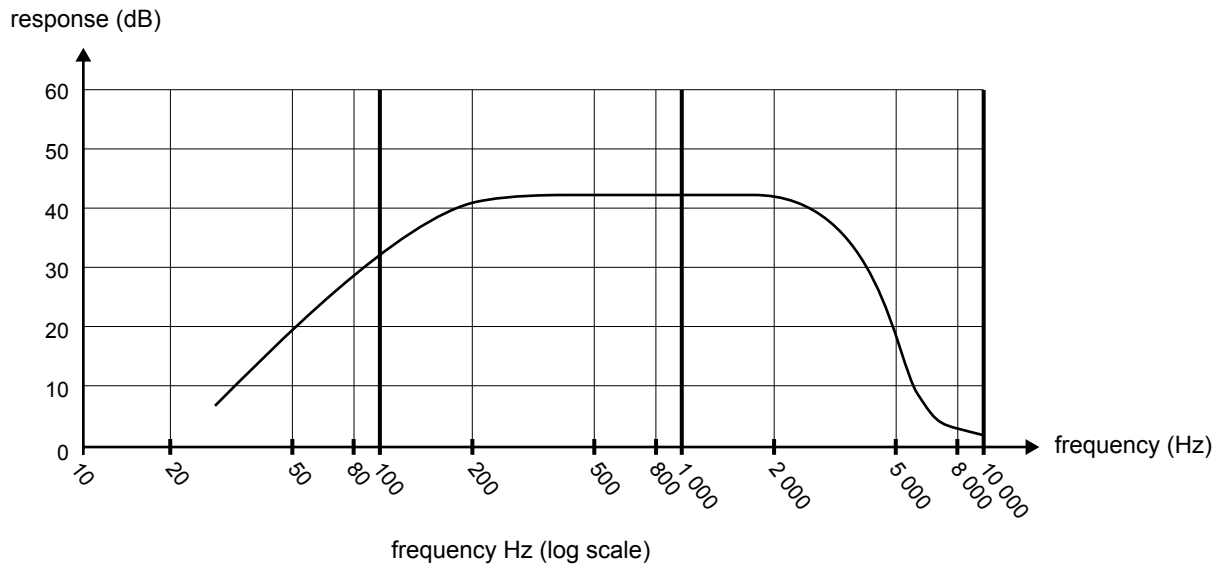

Figure 2

Question 7

From the data on the graph, what makes this microphone particularly suitable for use by a singer?

2 marks

Use the following information to answer Questions 8–11.

Two sound engineers are testing the acoustics of an outdoor performance area. The area consists of a covered stage and open-air seating area, as shown in Figure 3. The width of the stage opening is 4.0 m.

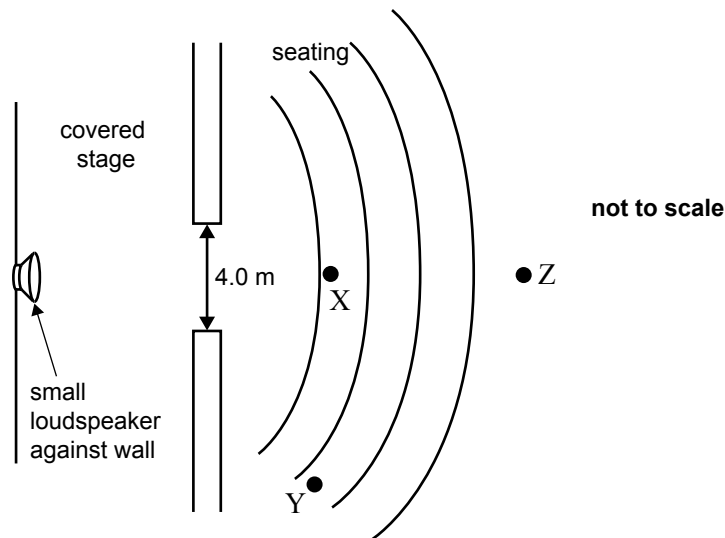

Figure 3

The sound engineers use two signals in turn, one of 200 Hz and one of 5000 Hz, from the small loudspeaker centrally located at the rear of the stage. The sound intensity level at the centre of the seating area (point X) with either of the frequencies is 60 dB, where 0 dB corresponds to a sound intensity of $1.0 \times 10^{-12} \text{ W m}^{-2}$, I_0 .

Question 8

What is the sound intensity, in W m^{-2} , at point X?

W m^{-2}

3 marks

The sound engineers measure the sound intensity level of the 200 Hz and 5000 Hz signals in turn at point Y, and find the levels are different.

Question 9

a. Which of the frequencies will be louder?

--

b. Give an explanation for this.

1 + 2 = 3 marks

The signal strength of the 5000 Hz signal is measured at X, and is found to be still 60 dB. The engineers then reduce the output of the small loudspeaker so that the sound intensity level at X is now 51 dB.

Question 10

Which one of the following (A–D) best gives the ratio of the sound intensity (W m^{-2}) at point X before and after the reduction?

- A. 60:51
- B. 9:1
- C. 8:1
- D. 3:1

2 marks

With the sound intensity level at X still 60 dB, measurements are now taken at point Z, twice the distance from the small loudspeaker as point X. Assume that the sound spreads out equally in all directions.

Question 11

Which one of the following (A–D) will be the best estimate of the sound intensity level (dB) at point Z?

- A. 30 dB
- B. 54 dB
- C. 57 dB
- D. 66 dB

2 marks

PHYSICS

Written examination 2

DATA SHEET

Directions to students

Detach this data sheet before commencing the examination.

This data sheet is provided for your reference.

1	photoelectric effect	$E_{k\max} = hf - W$
2	photon energy	$E = hf$
3	photon momentum	$p = \frac{h}{\lambda}$
4	de Broglie wavelength	$\lambda = \frac{h}{p}$
5	resistors in series	$R_T = R_1 + R_2$
6	resistors in parallel	$\frac{1}{R_T} = \frac{1}{R_1} + \frac{1}{R_2}$
7	magnetic force	$F = I l B$
8	electromagnetic induction	emf : $\varepsilon = -N \frac{\Delta\Phi}{\Delta t}$ flux: $\Phi = BA$
9	transformer action	$\frac{V_1}{V_2} = \frac{N_1}{N_2}$
10	AC voltage and current	$V_{\text{RMS}} = \frac{1}{\sqrt{2}} V_{\text{peak}}$ $I_{\text{RMS}} = \frac{1}{\sqrt{2}} I_{\text{peak}}$
11	voltage; power	$V = RI$ $P = VI$
12	transmission losses	$V_{\text{drop}} = I_{\text{line}} R_{\text{line}}$ $P_{\text{loss}} = I_{\text{line}}^2 R_{\text{line}}$
13	mass of the electron	$m_e = 9.11 \times 10^{-31} \text{ kg}$
14	charge on the electron	$e = -1.60 \times 10^{-19} \text{ C}$
15	Planck's constant	$h = 6.63 \times 10^{-34} \text{ J s}$ $h = 4.14 \times 10^{-15} \text{ eV s}$
16	speed of light	$c = 3.0 \times 10^8 \text{ m s}^{-1}$

Detailed study 3.1 – Synchrotron and applications

17	energy transformations for electrons in an electron gun (<100 keV)	$\frac{1}{2} m v^2 = eV$
18	radius of electron beam	$r = mv/eB$
19	force on an electron	$F = evB$
20	Bragg's law	$n\lambda = 2d\sin\theta$
21	electric field between charged plates	$E = \frac{V}{d}$

Detailed study 3.2 – Photonics

22	band gap energy	$E = \frac{hc}{\lambda}$
23	Snell's law	$n_1 \sin i = n_2 \sin r$

Detailed study 3.3 – Sound

24	speed, frequency and wavelength	$v = f\lambda$
25	intensity and levels	<p>sound intensity level (in dB) = $10 \log_{10} \left(\frac{I}{I_0} \right)$ where $I_0 = 1.0 \times 10^{-12} \text{ W m}^{-2}$</p>

Prefixes/Units

p = pico = 10^{-12}

n = nano = 10^{-9}

μ = micro = 10^{-6}

m = milli = 10^{-3}

k = kilo = 10^3

M = mega = 10^6

G = giga = 10^9

t = tonne = 10^3 kg

END OF DATA SHEET