



Victorian Certificate of Education 2002

SUPERVISOR TO ATTACH PROCESSING LABEL HERE

STUDENT NUMBER

Figures	<input type="text"/>	<input type="text"/>	<input type="text"/>	<input type="text"/>	<input type="text"/>	<input type="text"/>	<input type="text"/>	<input type="text"/>	Letter
Words	<input type="text"/>	<input type="text"/>	<input type="text"/>	<input type="text"/>	<input type="text"/>	<input type="text"/>	<input type="text"/>	<input type="text"/>	<input type="text"/>

PHYSICS

Written examination 2

Tuesday 12 November 2002

Reading time: 9.00 am to 9.15 am (15 minutes)

Writing time: 9.15 am to 10.45 am (1 hour 30 minutes)

QUESTION AND ANSWER BOOK

Structure of book

<i>Area</i>	<i>Number of questions</i>	<i>Number of questions to be answered</i>	<i>Number of marks</i>
1. Motion	16	16	36
2. Gravity	6	6	14
3. Structures and materials	7	7	22
4. Ideas about light and matter	7	7	18
			Total 90

- Students are permitted to bring into the examination room: pens, pencils, highlighters, erasers, sharpeners, rulers, up to two pages (one A4 sheet) of pre-written notes (typed or handwritten) and an approved graphics calculator (memory cleared) and/or one scientific calculator.
- Students are NOT permitted to bring into the examination room: blank sheets of paper and/or white out liquid/tape.

Materials supplied

- Question and answer book of 25 pages, with a detachable data sheet in the centrefold.

Instructions

- Detach the data sheet from the centre of this book during reading time.
- Write your **student number** in the space provided above on this page.
- Answer all questions in the spaces provided.
- **Always** show your working where space is provided because marks may be awarded for this working.
- All written responses must be in English.

Students are NOT permitted to bring mobile phones and/or any other electronic communication devices into the examination room.

AREA 1 – Motion

In a road test, a car was uniformly accelerated from rest over a distance of 400 m in 19.0 s. The driver then applied the brakes, stopping the car in 5.1 s with constant deceleration.

Question 1

Calculate the acceleration of the car for the first 400 m.

2 marks

Question 2

Calculate the average speed of the car for the entire journey, covering both the acceleration and braking sections.

2 marks

The graphs (A–F) in the key below should be used when answering Questions 3 and 4. The horizontal axis represents time and the vertical axis could be velocity or distance.

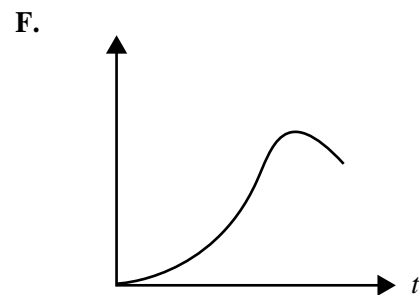
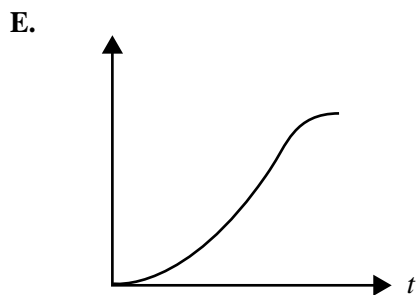
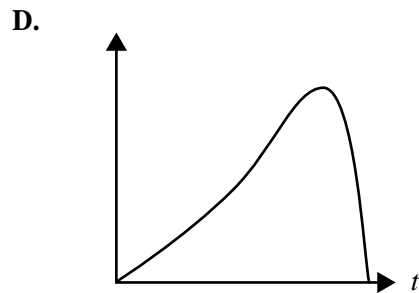
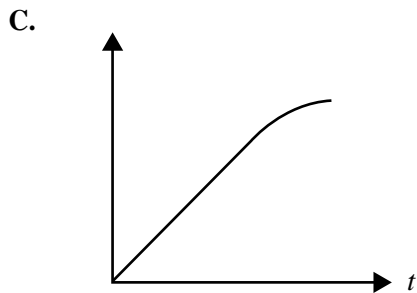
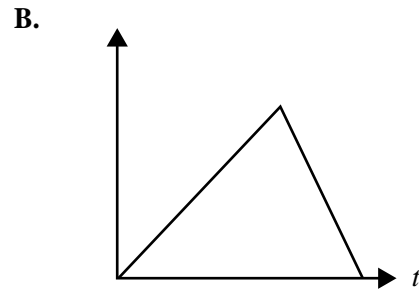
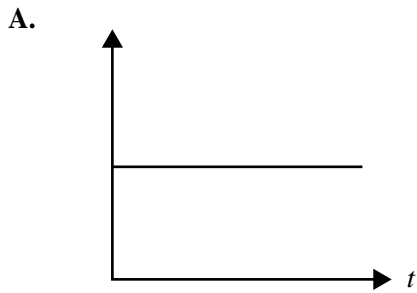

KEY

Question 3

Which of the graphs (A–F) best represents the velocity–time graph of the car for the entire journey?

2 marks

Question 4

Which of the graphs (A–F) best represents the distance–time graph of the car for the entire journey?

2 marks

**AREA 1 – continued
TURN OVER**

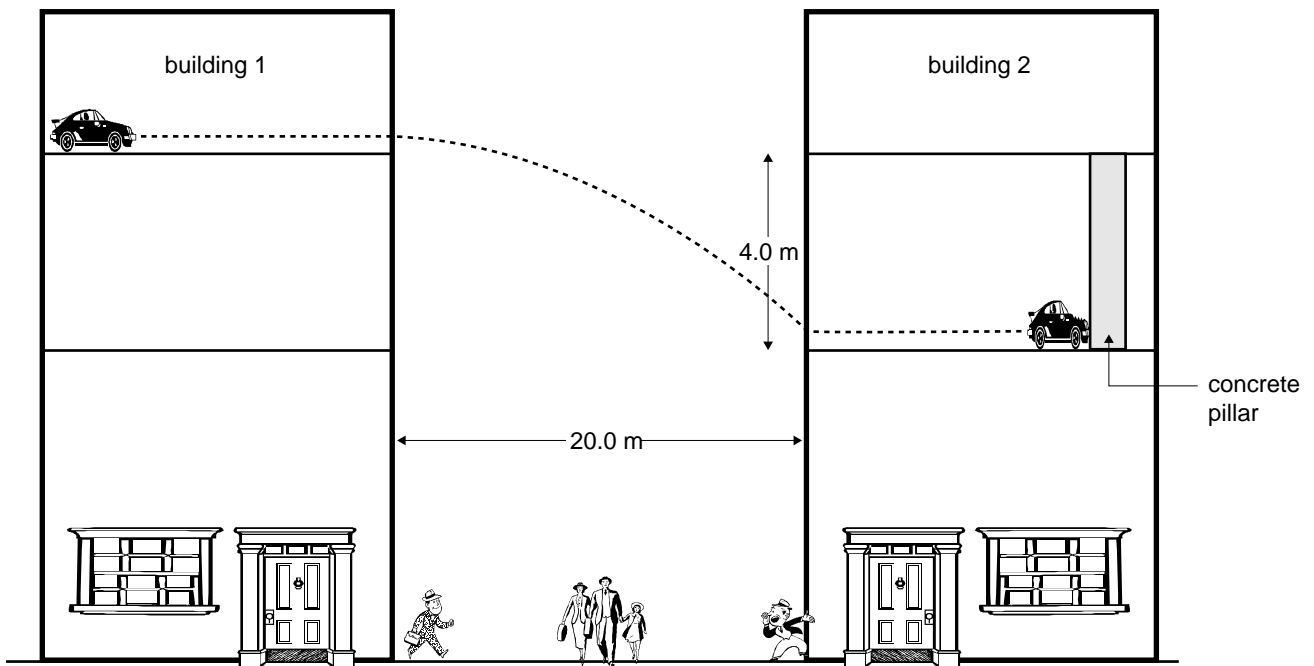

Figure 1

In the movie, *Car Escape*, Taylor and Jones drove their sportscar across a horizontal car park in building 1 and landed it in the car park of building 2, landing one floor lower. Building 2 is 20 metres from building 1, as shown in Figure 1. The floor where the car lands in building 2 is 4.0 m below the floor from which it started in building 1. In Questions 5 and 6, treat the car as a point particle and assume air resistance is negligible.

Question 5

Calculate the minimum speed at which the car should leave building 1 in order to land in the car park of building 2.

m s^{-1}

3 marks

In order to be sure of landing in the car park of building 2, Taylor and Jones in fact left building 1 at a speed of 25 m s^{-1} .

Question 6

Calculate the magnitude of the **velocity** of the car just prior to landing in the car park of building 2.

m s^{-1}

2 marks

After landing, Taylor applies the brakes and the car slows down until its speed is 11.0 m s^{-1} . The car then collides head-on with a concrete pillar. The car comes to rest in a time of 0.10 s . The car comes to rest against the pillar. The mass of the car and occupants is 1.30 tonne .

Question 7

Determine the average force on the car during the impact with the pillar.

N

2 marks

Question 8

Explain how the crumple zone of the car can minimise the extent of injuries experienced by the occupants of the car. (Assume that the occupants are wearing seatbelts.)

3 marks

AREA 1 – continued
TURN OVER

A moving railway truck (X) of mass 10 tonnes, moving at 6.0 m s^{-1} , collides with a stationary railway truck (Y) of mass 5.0 tonnes. After the collision they are joined together and move off as one. This situation is shown in Figure 2.

before collision

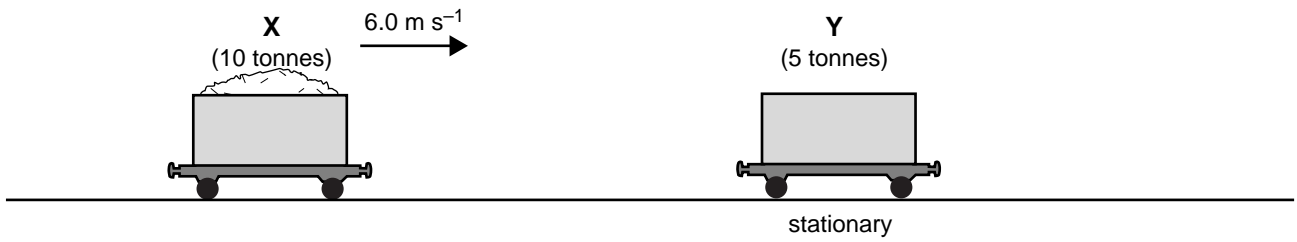

after collision



Figure 2

Question 9

Calculate the final speed of the joined railway trucks after the collision.

m s^{-1}

2 marks

Question 10

Calculate the magnitude of the total impulse that truck Y exerts on truck X during the collision.

N s

2 marks

Question 11

Explain why this is an example of an inelastic collision. Calculate specific numerical values to justify your answer.

3 marks

CONTINUED OVER PAGE

A toy train engine of mass 0.25 kg travels around a flat circular section of a track of radius 2.0 m at a uniform speed of 3.0 m s^{-1} as shown in Figure 3.

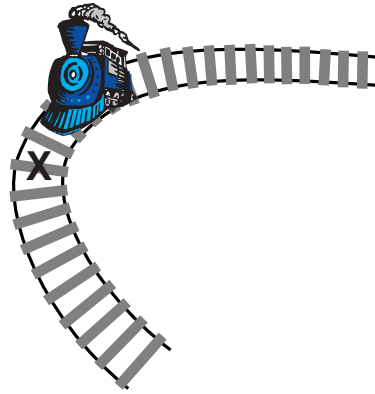

Figure 3

Question 12

Calculate the net force acting on the train engine as it travels around the curve of the track.

N

2 marks

The train engine wheels are in contact with the track as it rounds the curve at point **X**. This is shown in Figure 4, as viewed facing the front of the engine.

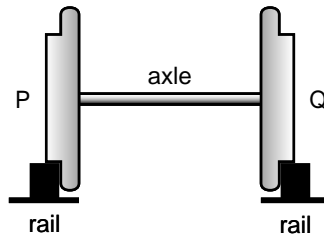

Figure 4

Question 13

Which one of the explanations (**A–F**) best describes the force(s) exerted on the wheels in order for the engine to travel around the curve at the point **X**.

The track exerts a force on

- A.** wheel P in the direction ←
- B.** wheel P in the direction →
- C.** wheel Q in the direction ←
- D.** wheel Q in the direction →
- E.** both wheels P and Q in the direction ←
- F.** both wheels P and Q in the direction →

2 marks

Figure 5 shows a cyclist with the bicycle wheels in **contact** with the road surface. The cyclist is about to start, accelerating forwards.



Figure 5

Question 14

Explain, with the aid of a clear force diagram, how the rotation of the wheels results in the cyclist accelerating forwards.

3 marks

The road safety slogan for 2002 is ‘Stay alive – wipe off five’. This is to encourage drivers to travel more slowly, so as to reduce the stopping distance when reacting to a hazard.

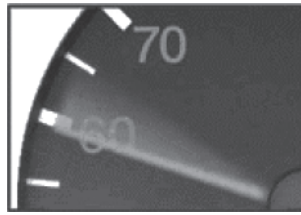

For a car travelling at 60 km h^{-1} the speed–time graph for a driver with a reaction time of 0.2 s and then braking to a stop with a constant braking force is shown in Figure 6.

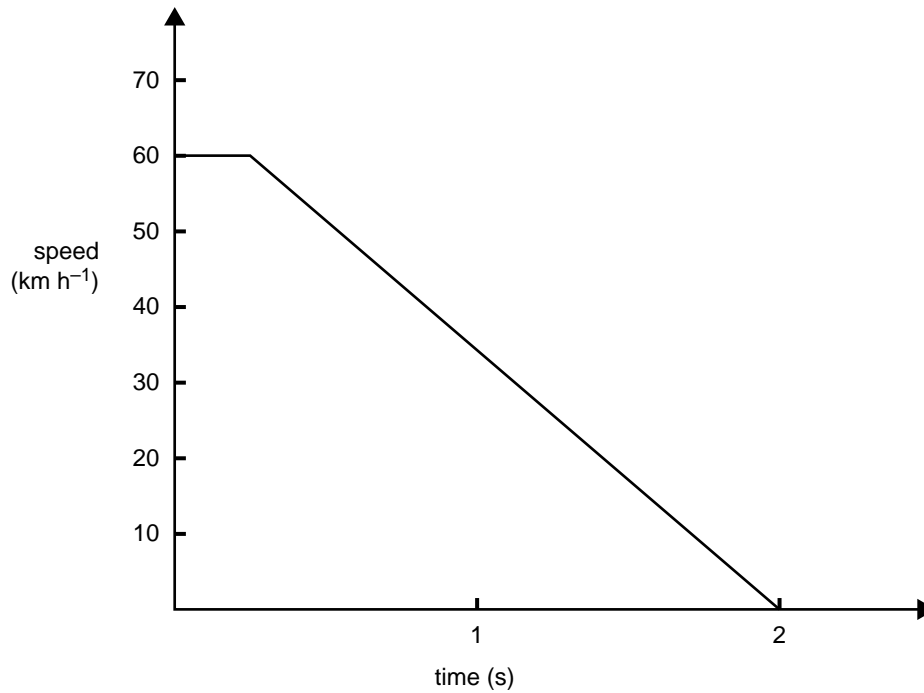

Figure 6

Question 15

On the **graph of Figure 6**, draw the speed–time graph for the same car and driver travelling at 65 km h^{-1} reacting to a hazard and then braking to a stop with the same constant braking force.

2 marks

Question 16

With reference to Figure 6, describe how you could determine the difference between the stopping distances at 65 km h^{-1} and 60 km h^{-1} .

2 marks

**END OF AREA 1
TURN OVER**

AREA 2 – Gravity

The Mars Odyssey spacecraft was launched from Earth on 7 April 2001 and arrived at Mars on 23 October 2001. Figure 1 is a graph of the gravitational force acting on the 700 kg Mars Odyssey spacecraft plotted against height above Earth’s surface.

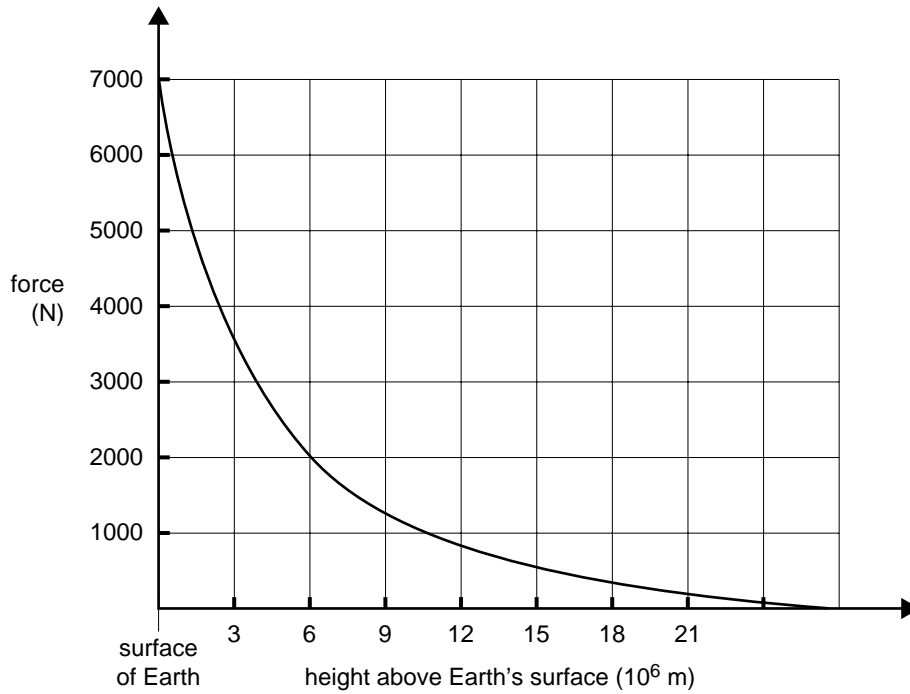

Figure 1

Question 1

Estimate the minimum launch energy needed for Mars Odyssey to escape Earth’s gravitational attraction.

J

3 marks

While in deep space, on the way to Mars, Odyssey was travelling at a constant velocity of $23\,000\text{ m s}^{-1}$ and the spacecraft and all its contents were weightless.

Question 2

Explain why an object inside the spacecraft could be described as weightless.

2 marks

CONTINUED OVER PAGE

Currently, the space probe, Cassini, is **between** Jupiter and Saturn (see Figure 2 opposite). Cassini's mission is to deliver a probe to one of Saturn's moons, Titan, and then orbit Saturn collecting data. Below is astronomical data that you may find useful when answering the following questions.



mass of Cassini	$2.2 \times 10^3 \text{ kg}$
mass of Jupiter	$1.9 \times 10^{27} \text{ kg}$
mass of Saturn	$5.7 \times 10^{26} \text{ kg}$
Saturn day	10.7 hours

Question 3

Calculate the magnitude of the total gravitational field experienced by Cassini when it is $4.2 \times 10^{11} \text{ m}$ from Jupiter and $3.9 \times 10^{11} \text{ m}$ from Saturn.

$$(G = 6.67 \times 10^{-11} \text{ N m}^2 \text{ kg}^{-2})$$

N kg^{-1}

4 marks

Question 4

Indicate the direction of the gravitational field at Cassini (determined in Question 3) on **Figure 2** below.

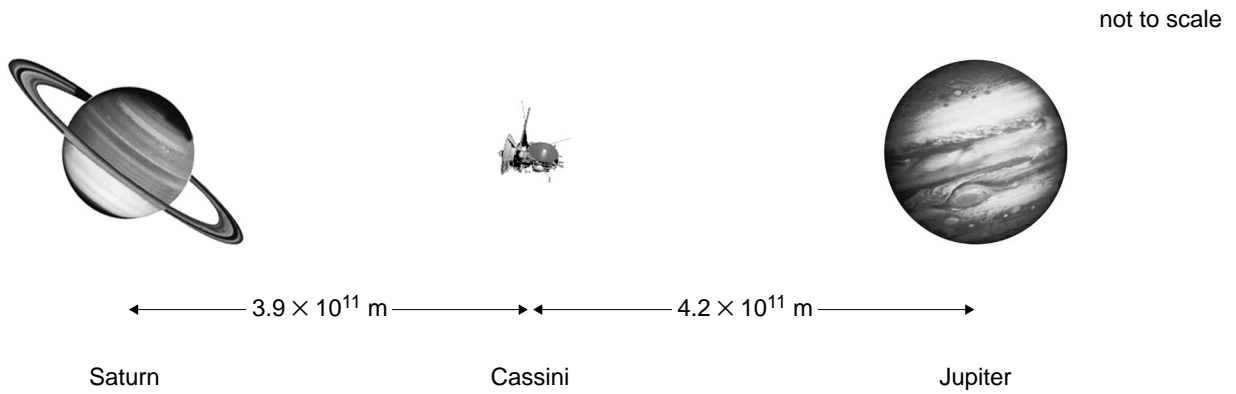

Figure 2. Cassini between Saturn and Jupiter (not drawn to scale)

1 mark

When Cassini arrives in the vicinity of Saturn this year, scientists want it to remain above the same point on Saturn's equator throughout one complete Saturn day. This is called a 'stationary' orbit.

Question 5

What is the period in seconds of this 'stationary' orbit?

 s

1 mark

Question 6

Calculate the radius of this 'stationary' orbit.

$$(G = 6.67 \times 10^{-11} \text{ N m}^2 \text{ kg}^{-2})$$

 m

3 marks

**END OF AREA 2
TURN OVER**

AREA 3 – Structures and materials

Three equally spaced wires support a radio mast as shown in Figure 1. Each wire has a diameter of 1.0 cm and makes an angle with the vertical of 30° . The tension in each wire is 5000 N and the radio mast itself has a mass of 2.0 tonnes.

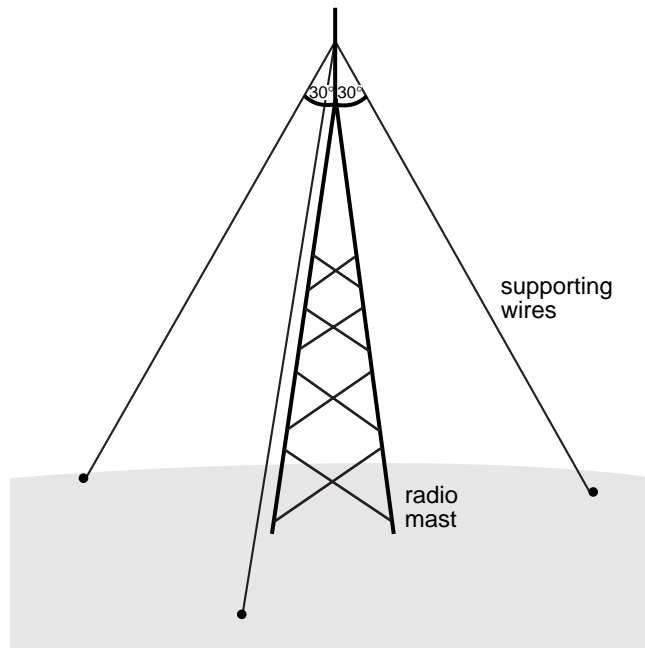

Figure 1

Question 1

Calculate the upthrust force that the ground exerts on the base of the radio mast.

$(g = 9.8 \text{ N kg}^{-1})$

N

3 marks

Question 2

Calculate the stress in each of the supporting wires.

Pa

3 marks

This page is blank

The bridge over an irrigation channel is shown in Figure 2. The bridge can be considered as a uniform concrete beam of length 30 m and mass 20 tonnes. A heavily loaded small truck of mass 6 tonnes is pictured crossing the bridge.

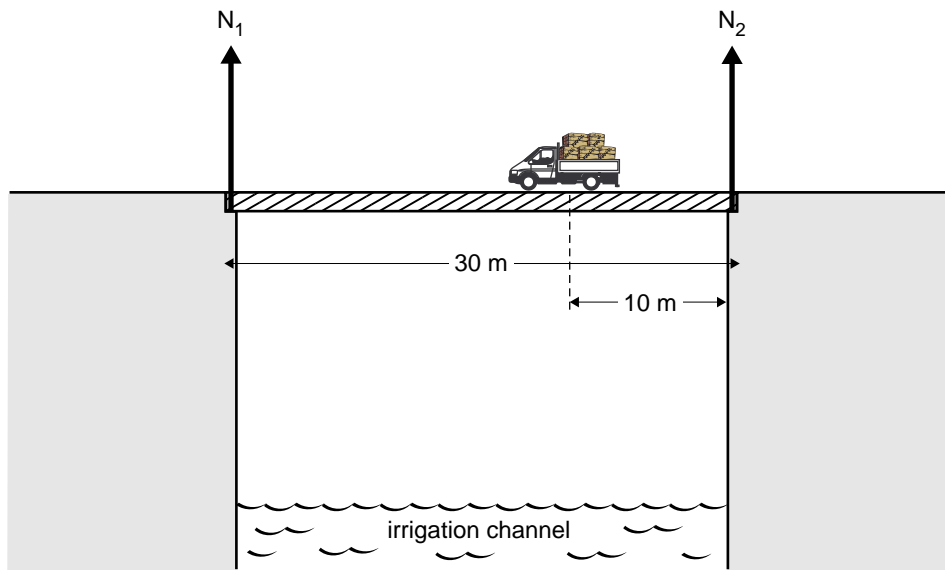

Figure 2

Question 3

Calculate the magnitude of each of the normal contact forces N_1 and N_2 at each end of the bridge when the centre of mass of the truck is 10 m from one end.

$N_1 =$	N
---------	---

$N_2 =$	N
---------	---

4 marks

As heavy vehicles cross the bridge it will bend slightly under the weight of these vehicles.

Question 4

Describe the stresses on the surfaces of the concrete bridge when heavy vehicles cross **and** explain the different construction methods that may have been used to ensure that the bridge is safe under such conditions.

3 marks

The graph in Figure 3 is from the web site of a manufacturer of rail steel. It shows tensile stress versus strain for samples of two types of steel; rail steel and structural steel.

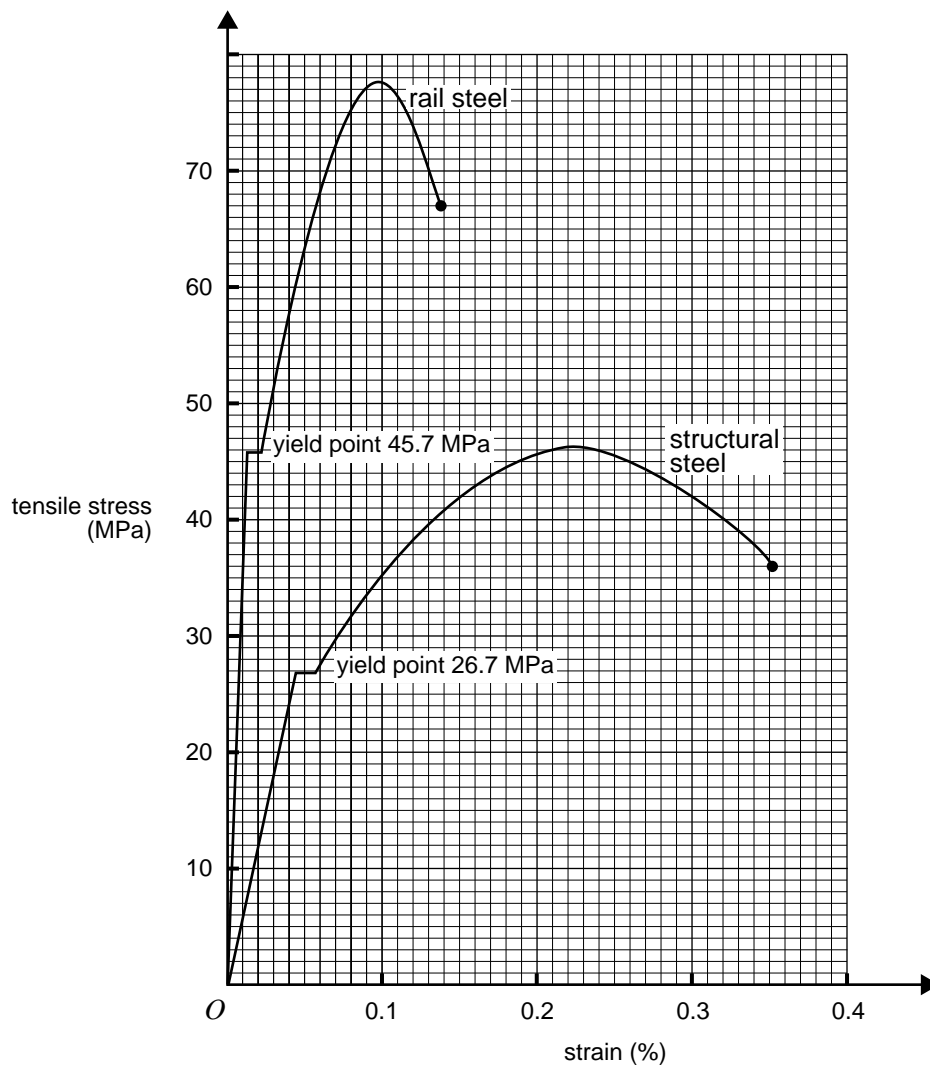

Figure 3

A 3.0 m rod of **structural steel** is placed under a tensile stress of 35 MPa.

Question 5

Calculate the amount that this rod will extend.

m

The manufacturers of rail steel make the following claims, in trying to show its advantage over structural steel.

Rail steel is noted for its strength. Its average yield point is greater than 43 MPa while actual tensile strength normally ranges from 71 MPa to 93 MPa. This high yield point means rail steel provides ample stiffness . . . enduring your heaviest demands with little deformation.

Rail steel is extremely tough. Rail steel resists breakage even after the yield point is exceeded. In addition, rail steel has a satisfactory amount of ductility.

Question 6

Explain whether the samples shown on the manufacturer's graph (Figure 3) support the manufacturer's claims for the strength and stiffness of rail steel compared with structural steel. Give reasons for your answer.

Strength

Stiffness

3 marks

Question 7

Refer to the graph of Figure 3 to explain whether rail steel is tougher than structural steel.

3 marks

AREA 4 – Ideas about light and matter**Figure 1**

Figure 1 shows a picture of diffraction of X-rays and electrons through aluminium foil. The picture has been made by combining an X-ray diffraction pattern (on the right) with an electron diffraction pattern (on the left). The pictures are to the same scale and the X-rays have a photon energy of 70 keV.

Question 1

Calculate the wavelength of the 70 keV X-rays.

$$(h = 4.14 \times 10^{-15} \text{ eV s}, c = 3.0 \times 10^8 \text{ m s}^{-1})$$

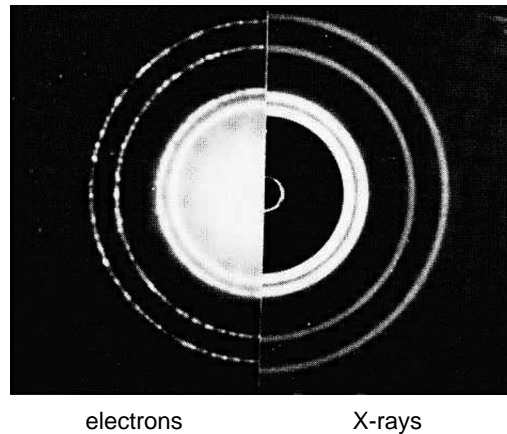
2 marks

Question 2

What is the de Broglie wavelength of the electrons?

2 marks

Question 3

Calculate the kinetic energy of the electrons in keV.

$$(h = 6.6 \times 10^{-34} \text{ J s}, m_e = 9.1 \times 10^{-31} \text{ kg}, e = 1.6 \times 10^{-19} \text{ C})$$

keV

4 marks

Question 4

Which of the statements (A–D) best explains why it is possible to compare X-ray and electron diffraction patterns?

- A. X-rays can exhibit particle-like properties.
- B. Electrons can exhibit wave-like properties.
- C. Electrons are a form of high energy X-rays.
- D. Both electrons and X-rays ionise matter.

--

2 marks

Young’s double slit experiment is set up by students in a laboratory as shown in Figure 2. Monochromatic light is shone onto the slits which are placed at a large distance from the screen. The intensity pattern produced on the screen is a pattern of light and dark bands.

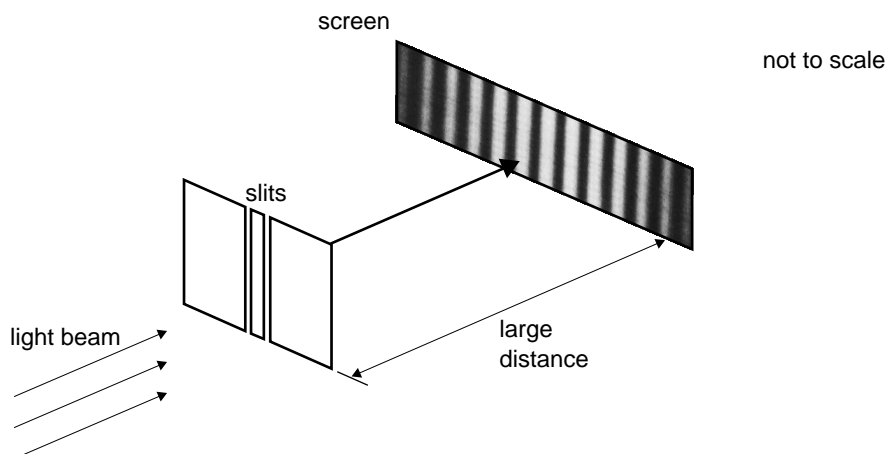

Figure 2

The students then wonder what will happen if the light used is white light rather than monochromatic light. All the students agree that there will be bands of colour on the screen, but have different opinions about the centre band. Pat expects a white band in the centre while Robyn believes a coloured band will be produced.

Question 5

Select which of the students is correct and justify your answer in the space below.

Pat / Robyn

3 marks

Blue light of frequency 6.25×10^{14} Hz is shone onto the sodium photocathode of a photocell. The graph of the photoelectric current versus potential difference is shown in Figure 3.

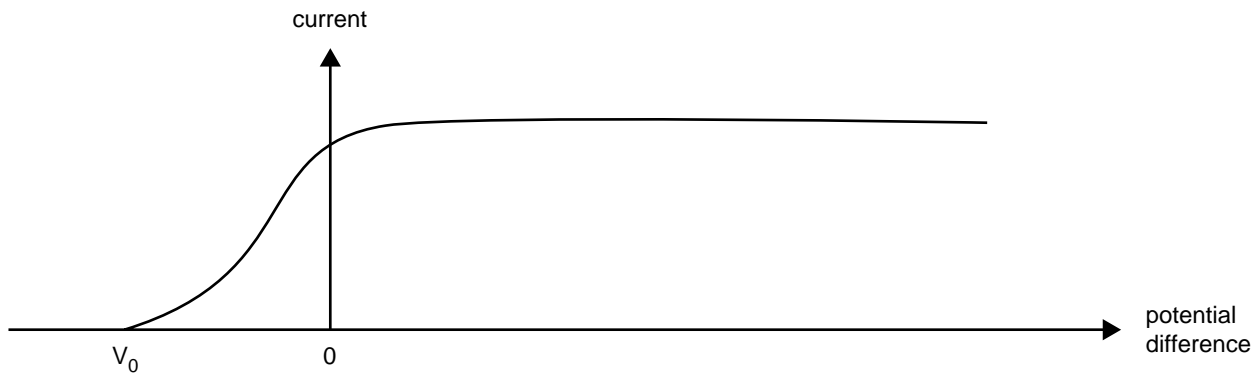

Figure 3

The threshold frequency for sodium is 5.50×10^{14} Hz.

Question 6

What is the cut-off potential, V_0 , when blue light of frequency 6.25×10^{14} Hz is shone onto the sodium photocathode of this photocell.

$$(h = 4.14 \times 10^{-15} \text{ eV s})$$

V

3 marks

Question 7

On **Figure 3** sketch the curve expected if the light is changed to **ultraviolet** with a **lower intensity** than the original.

2 marks

END OF QUESTION AND ANSWER BOOK

PHYSICS

Written examination 2

DATA SHEET

Directions to students

Detach this data sheet before commencing the examination.

This data sheet is provided for your reference.

1	velocity; acceleration	$v = \frac{\Delta x}{\Delta t}; \quad a = \frac{\Delta v}{\Delta t}$
2	equations for constant acceleration	$v = u + at$ $x = ut + \frac{1}{2}at^2$ $v^2 = u^2 + 2ax$ $x = \frac{1}{2}(v + u)t$
3	Newton's second law	$F = ma$
4	circular motion	$a = \frac{v^2}{r} = \frac{4\pi^2 r}{T^2}$
5	Hooke's law	$F = -kx$
6	elastic potential energy	$\frac{1}{2}kx^2$
7	gravitational potential energy near the surface of the Earth	mgh
8	kinetic energy	$\frac{1}{2}mv^2$
9	torque	$\tau = Fr$
10	Newton's law of universal gravitation	$F = G \frac{M_1 M_2}{r^2}$
11	gravitational field	$g = G \frac{M}{r^2}$
12	stress	$\sigma = \frac{F}{A}$
13	strain	$\epsilon = \frac{\Delta L}{L}$
14	Young's modulus	$E = \frac{\text{stress}}{\text{strain}}$
15	electric force on charged particle in an electric field	$F = qE$
16	electric field between charged plates	$E = \frac{V}{d}$
17	energy change of charged particle moving between charged plates	$\Delta E_k = qV$
18	photoelectric effect	$E_{k \max} = hf - W$
19	photon energy	hf
20	photon momentum	$p = \frac{h}{\lambda}$
21	de Broglie wavelength	$\lambda = \frac{h}{p}$

Gravitational field strength at the surface of Earth	$g = 9.8 \text{ N kg}^{-1}$
Universal gravitational constant	$G = 6.67 \times 10^{-11} \text{ N m}^2 \text{ kg}^{-2}$
Mass of Earth	$M_E = 5.98 \times 10^{24} \text{ kg}$
Radius of Earth	$R_E = 6.37 \times 10^6 \text{ m}$
Mass of the Sun	$M_{\text{SUN}} = 2.0 \times 10^{30} \text{ kg}$
Mass of the electron	$m_e = 9.1 \times 10^{-31} \text{ kg}$
Charge on the electron	$e = 1.6 \times 10^{-19} \text{ C}$
Planck's constant	$h = 6.63 \times 10^{-34} \text{ J s}$ $h = 4.14 \times 10^{-15} \text{ eV s}$
Speed of light	$c = 3.0 \times 10^8 \text{ m s}^{-1}$

Prefixes/Units

$$\text{m} = \text{milli} = 10^{-3}$$

$$\mu = \text{micro} = 10^{-6}$$

$$\text{n} = \text{nano} = 10^{-9}$$

$$\text{k} = \text{kilo} = 10^3$$

$$\text{M} = \text{mega} = 10^6$$

$$\text{G} = \text{giga} = 10^9$$

$$\text{tonne} = 10^3 \text{ kg}$$

END OF DATA SHEET