

2019 VCE Systems Engineering examination report

General comments

Many students found the electrical section of the exam to be difficult as they required the application of technical knowledge. The mechanical and systems engineering processes questions were generally well answered. Students should note that all of the key knowledge and skills specified in the study design may be assessed.

Students need to read questions carefully and answer them fully; for example, Question 14 asked for examples, but most students did not give them, and Question 12 asked 'how will the instrument identified' be used but many students did not explain how.

Specific information

This report provides sample answers or an indication of what the answers may have included. Unless otherwise stated, these are not intended to be exemplary or complete responses.

The statistics in this report may be subject to rounding resulting in a total of more or less than 100 per cent.

Section A – Multiple-choice questions

The following table indicates the percentage of students who chose each option. The correct answer is indicated by shading.

Question	% A	% B	% C	% D	Comments
1	29	50	14	7	
2	1	8	44	48	
3	24	10	49	17	
4	9	24	27	40	
5	20	55	3	21	
6	9	17	19	56	
7	45	18	28	8	A transducer converts a physical quantity to an electrical signal or vice versa

Question	% A	% B	% C	% D	Comments
8	10	42	20	27	Capacitors in parallel add together. $1 \mu F + 0.5 \mu F = 1.5 \mu F$ $\frac{1}{1.5 \mu F} + \frac{1}{300 nF} = \frac{1}{250 nF}$
9	13	11	66	11	
10	58	39	2	2	
11	5	25	30	40	
12	31	4	55	10	To convert peak voltage to rms voltage, divide by $\sqrt{2}$ $P = \frac{V^2}{R}$
13	14	11	9	66	
14	82	11	6	1	
15	2	7	86	6	
16	21	6	2	71	
17	2	25	69	4	The ratio of the area of the top of the piston is the important variable. The ratio of the area of Piston A to Piston B is 1:4. Therefore, Piston B will move $\frac{1}{4}$ of the distance of Piston A.
18	8	2	5	86	
19	8	4	85	3	
20	82	7	6	4	

Section B

Question 1

Marks	0	1	2	3	Average
%	7	26	58	9	1.7

The correct completion of the block diagram was as follows.

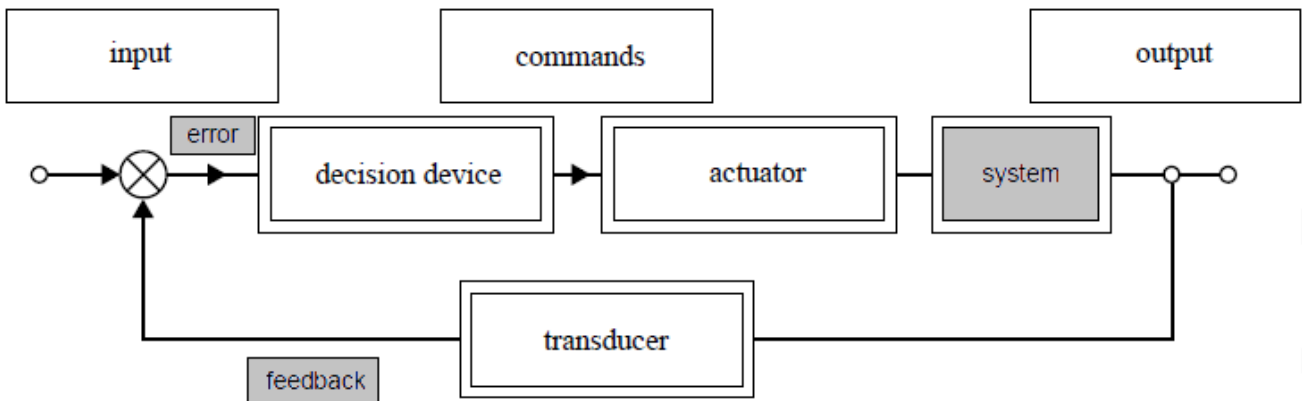

Question 2

Marks	0	1	2	3	4	Average
%	9	38	32	16	5	1.7

The four steps that must be taken to control the health and safety risks of a hazard were as follows.

- Identify the risk
- Assess the risk (evaluate)
- Control the risk (isolate, reduce/remove hazard, notify, PPE, eliminate, act with caution)
- Review the risk control

Only one answer from each category was accepted.

Question 3

Marks	0	1	2	3	Average
%	70	5	4	20	0.8

The completed printed circuit board layout, showing the 11 missing connections, is shown below. The components were not to be drawn on the circuit board. They are only drawn here in order to see the placement of the tracks.

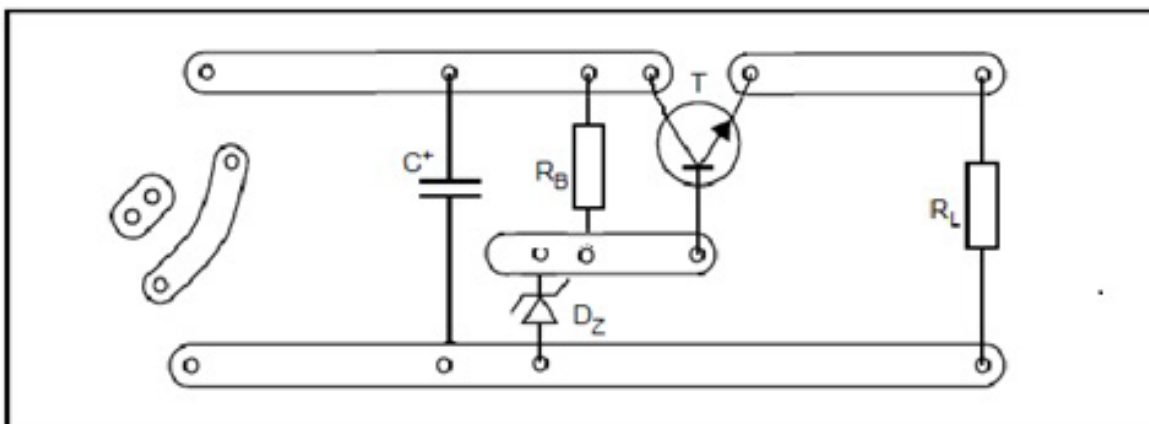

The bridge rectifier in the circuit diagram is a single component. Some students assumed that there were four individual diodes.

Question 4ai.

Marks	0	1	Average
%	64	36	0.4

The name of the circuit was voltage regulator. The function of the circuit was to convert AC to DC.

Question 4aii.

Marks	0	1	Average
%	97	3	0.1

The expected reading of the voltmeter V was 10 V (9.3 or 9.4 V if the voltage drop across the transistor was included).

Question 4b.

Marks	0	1	2	3	Average
%	96	3	0	1	0.1

The mistake in the design of the circuit was that there was not enough current through the Zener diode D_z . Students were required to show working.

$$I = 24/50\ 000 = 0.48\ \text{mA}$$

Justification by giving the current through the diode was needed to earn full marks.

Question 4c.

Marks	0	1	2	Average
%	96	4	1	0.1

The mistake identified in Question 4b. could be addressed by the following.

Resistor R_1 needs to be 14 K Ω or smaller.

$$I = 1\ \text{mA} \quad (24 - 10) / R_1 = 0.001$$

$$R_1 = 14/0.001 = 14\ \text{K}\Omega \text{ or smaller.}$$

A calculation to determine the size of the resistor was needed to earn full marks.

Question 4d.

Marks	0	1	2	Average
%	96	3	1	0.1

Another mistake in the design of the circuit was that the capacitor rating was too small.

This could be fixed by replacement with a capacitor rated over 34 V

$$(24 \times 1.41 = 34\ \text{V})$$

All capacitors should have a voltage rating above the peak voltage of the circuit. A 24 V supply has a peak voltage of $24\ \text{V} \times \sqrt{2} \sim 34\ \text{V}$.

Question 5a.

Marks	0	1	2	Average
%	44	37	18	0.8

Brand A was the more economical choice.

Brand A

Power = $24\text{ V} \times 1\text{ A} = 24\text{ W}$. Cost per panel $\$200/24\text{ W} = \$8.33 / \text{W}$

Brand B

Power = $36\text{ V} \times 0.5\text{ A} = 18\text{ W}$. Cost per panel $\$175/18\text{ W} = \$9.72 / \text{W}$

Question 5b.

Marks	0	1	2	Average
%	43	25	33	0.9

If Brand A was selected:

40% of 10 000 W = 4000 W

4000 W are needed and each panel is 24 W so:

$$\frac{4000}{24} = 166.667$$

Round up to give 167 panels.

If Brand B was selected, marks were awarded for appropriate working.

Question 5ci.

Marks	0	1	Average
%	75	25	0.3

The other subsystem that had to be introduced into the solar panel system was an AC inverter.

Question 5cii.

Marks	0	1	Average
%	92	8	0.1

The power of the subsystem identified in Question 5ci was greater than 4 kW.

40% of 10 000 = 4 kW

Question 5d.

Marks	0	1	Average
%	63	37	0.4

An optional subsystem that could be included in the solar panel system to improve its efficiency could be:

- batteries to store any extra energy produced by the solar panels during the day
- moving panels.

Question 5e.

Marks	0	1	2	Average
%	21	17	62	1.4

Possible options for the energy to be used even when the factory's machines are not operating could be:

- the use of batteries to store any extra energy
- returning energy to the grid
- using the energy to run other systems in the factory.

Question 6a.

Marks	0	1	2	Average
%	47	19	35	0.9

$$\frac{(20 \Omega + 20 \Omega) \times (20 \Omega + 20 \Omega)}{(20 \Omega + 20 \Omega) + (20 \Omega + 20 \Omega)} + 20 \Omega = 40 \Omega$$

The total resistance of the circuit was 40Ω .

This was a combination of series and parallel resistors.

Question 6b.

Marks	0	1	2	Average
%	44	50	5	0.6

Students were required to calculate the current displayed by the ammeter and the voltage displayed by the voltmeter. The answers were:

Ammeter 0.75 A

Voltmeter 22.5 V

Students were required to show working:

Total voltage is 30 V . Total resistance is 40Ω . $I = \frac{V}{R}$

$$V = 0.75 \times 30 = 22.5 \text{ V}$$

Voltage across R_5 is 15 V .

Therefore, voltage across R_4 is $15/2$ or 7.5 V .

Hence the voltmeter reading is $7.5 + 15 = 22.5 \text{ V}$

Question 6c.

Marks	0	1	2	Average
%	91	3	6	0.2

The power dissipated by the resistor R_2 was
 2.8125 W

$$I = 0.75/2 = 375 \text{ mA}; P = 375 \text{ mA} \times 7.5$$

Question 6d.

Marks	0	1	Average
%	69	31	0.3

Students were required to calculate the total power supplied to the circuit.

$$P = I^2 \times R = 0.75 \times 0.75 \times 40$$

Total power supplied to the circuit = 22.5 W

Question 7a.

Marks	0	1	Average
%	28	72	0.7

The student would identify the constraints for their project at the start of the project.

Variations were accepted, such as the research stage, the planning stage.

Question 7b.

Marks	0	1	2	Average
%	36	15	49	1.2

The student would have chosen to use a brushless DC electric motor because brushless DC motors are more efficient and more reliable than brushed DC motors.

Question 7c.

Marks	0	1	Average
%	29	71	0.7

The maximum rpm of Gear B was 2000 rpm.

Question 7d.

Marks	0	1	2	3	Average
%	67	15	2	15	0.7

The distance travelled by the electric hybrid bicycle would be 5.92 km.

Current drawn by motor:

$$I = P / V = 200 / 14.8 = 13.51 \text{ A}$$

Motor run time:

$$t = 10 / 13.51 = 0.74 \text{ h (1)}$$

distance = speed x time

$$\Rightarrow \text{distance} = 8 \times 0.74 = 5.92$$

Question 8a.

Marks	0	1	2	Average
%	29	25	46	1.2

The maximum power required by each hydraulic jack was 18 W.

work done = 360 J

Power = work done / time

Power = 360 / 20 = 18 W

Question 8b.

Marks	0	1	2	3	Average
%	46	19	10	25	1.2

The oil pressure in the cylinder at the maximum rated capacity was 4.24 MPa.

area = $7.0686 \times 10^{-6} \text{ m}^2$

$3000 / 7.0686 \times 10^{-6}$

pressure = $4.24 \times 10^6 \text{ Pa}$

Question 9

Marks	0	1	2	3	Average
%	45	17	2	35	1.3

The efficiency of the pulley system was 83%.

$50 / 60 \times 100\% = 83.33\%$

A common error was to calculate $50 / 15 = 3.33$.

Question 10a.

Marks	0	1	2	Average
%	12	2	86	1.8

The wheel and axle had to be labelled as follows.

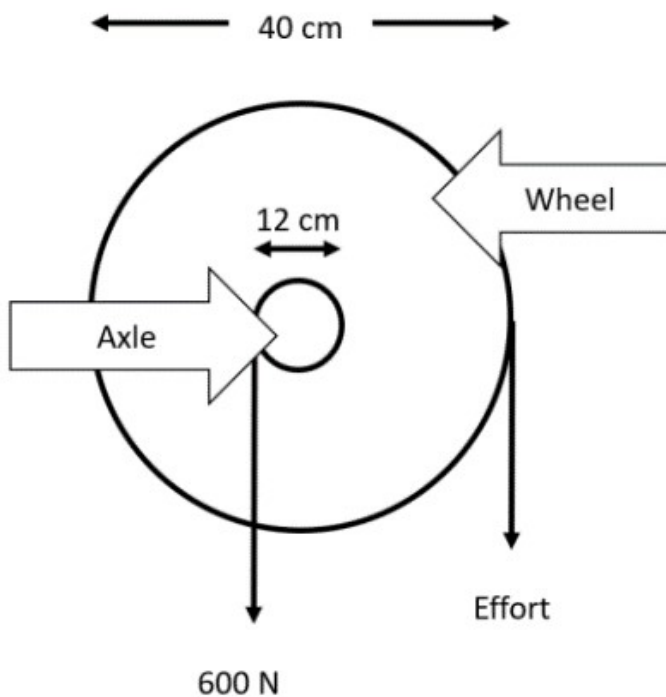

Question 10b.

Marks	0	1	2	Average
%	50	7	42	0.9

$$\frac{\text{diameter of driven pulley}}{\text{diameter of driver pulley}} = \frac{40 \text{ cm}}{12 \text{ cm}} \sim 3.3$$

The mechanical advantage of the system was 3.3.

An equivalent fraction in simplest form was accepted.

Question 11a.

Marks	0	1	2	Average
%	18	33	49	1.3

Potential environmental impacts that would have to be considered if Option 1 was selected could include:

- a threat to wildlife
- visual impact
- noise pollution
- effects on ecosystems.

Question 11b.

Marks	0	1	2	Average
%	45	20	36	0.9

The heat from deep below Earth's surface could be captured as steam/boiling water, which could then be used in a turbine/generator to produce electricity.

Question 11c.

Marks	0	1	Average
%	46	54	0.6

Geothermal energy could be considered a better option than wind power (ignoring environmental impacts, because it provides a constant supply.

Geothermal energy provides a stable and reliable source of energy, unlike wind power, which is dependent on the weather to keep blades spinning and thus generating electricity.

Question 12a.

Marks	0	1	Average
%	36	64	0.7

One suitable diagnostic testing instrument could be:

- a digital multimeter
- a voltmeter
- an ammeter
- an oscilloscope
- a continuity tester

Question 12b.

Marks	0	1	2	Average
%	44	36	20	0.8

This answer needed to relate to the instrument selected in Question 12a.

For example, the voltmeter could allow checking for faults in the electronic subsystem by placing the probes of the voltmeter across components to see if the voltage drop was as expected.

Question 12c.

Marks	0	1	2	3	4	Average
%	29	14	31	8	18	1.7

These issues identified needed to relate directly to the mechanical pulley mechanism; for example:

Issue 1

A chicken could interfere with the pulley system. To overcome this issue, a guard could be placed around the pulleys.

Question 13a.

Marks	0	1	2	Average
%	50	26	24	0.8

One electrical safety issue could be that students could interfere with the long extension cord and live wires may be exposed. This could cause electrocution. Another issue could be deterioration of the extension cord if left exposed to weather.

Question 13b.

Marks	0	1	2	Average
%	37	19	44	1.1

One workable solution could be placing the long extension cord in a conduit underground. Another could be suspending the cord on overhead power poles.

Question 13c.

Marks	0	1	Average
%	24	76	0.8

The minimum total resistance of the wire in the extension cord was 32Ω .

$$R = 0.08 \times 200 \times 2 = 16 \times 2 = 32\Omega$$

Question 13d.

Marks	0	1	2	Average
%	52	12	36	0.9

The additional circuit required for the system was a rectifier.

The reason is that the 12 V AC supply needed to be converted to DC.

Question 13e.

Marks	0	1	2	Average
%	38	38	24	0.9

Increased diameter was the characteristic of the wire that would improve the efficiency of transmission. This is because the wire would be more conductive.

Question 14

Marks	0	1	2	3	4	5	Average
%	16	10	19	29	20	7	2.5

High-scoring responses included both positive and negative impacts, and gave examples of each.