

2020 VCE Systems Engineering written examination report

General comments

In 2020 the Victorian Curriculum and Assessment Authority produced an examination based on the *VCE Systems Engineering Adjusted Study Design for 2020 only*.

Students generally made a good attempt to complete the 2020 VCE Systems Engineering examination. The wide range of question difficulty gave students the opportunity to demonstrate their abilities.

Specific information

This report provides answers or an indication of what answers may have included. Unless specifically stated these are not intended to be exemplary or complete responses.

The statistics in this report may be subject to rounding resulting in a total more or less than 100 per cent.

Section A – Multiple-choice questions

The following table indicates the percentage of students who chose each option. The correct answer is indicated by shading.

Question	% A	% B	% C	% D	% N/A	Comments
1	35	39	17	9	0	Distance from force to pivot is 4 m ($4 \text{ m} \times 1 \text{ m} = 4$).
2	7	20	53	20	0	One zero $10^5 = 1\,000\,000$ ohms or 1 M Ω
3	3	27	6	65	0	
4	9	7	74	9	0	
5	22	55	12	10	1	Resistance of parallel branch is $(40 \times 40) / (40 + 40) \Omega$ Total resistance is 40 Ω so total current is 1A
6	13	12	56	17	1	Gold is a tolerance of 5% 5% of 4K7 is 235
7	51	5	5	38	1	Energy = V.I.T Time and voltage will be the same for all. The 10 Ω will have the most current, therefore the most energy.
8	18	14	52	15	0	
9	2	3	1	95	0	
10	11	66	7	16	0	

Question	% A	% B	% C	% D	% N/A	Comments
11	1	13	3	83	0	
12	3	3	89	5	0	
13	27	5	5	62	0	
14	29	41	16	15	0	Work done = force x distance The vertical distance is the same for all cases.
15	17	27	30	25	0	The ratio of the surface area of the pistons is the key. As the diameter is doubled, the area is increased by a factor of 4
16	77	8	4	10	0	
17	6	8	11	76	0	
18	8	78	10	3	1	
19	95	2	2	2	0	
20	1	49	47	3	0	At the start, the energy stored by the water in the dam is potential.

Section B

Question 1

Marks	0	1	2	Average
%	2	2	95	1.9

This is block diagram of an automated controlled system.

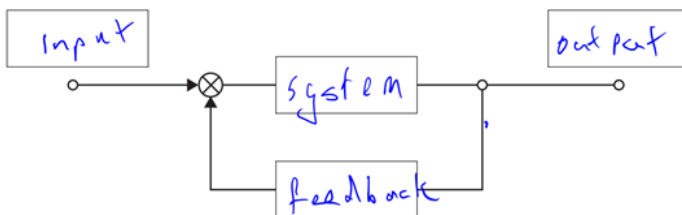

Question 2a.

Marks	0	1	2	Average
%	54	5	41	0.9

The force required by the electric motor to pull the load is 600 N.

Work = Force \times Distance

The distance is 5 using a 3, 4, 5 triangle or Pythagorean theorem

$$3000 = F \times 5$$

$$F = 600 \text{ N}$$

Question 2b.

Marks	0	1	2	Average
%	36	11	54	1.2

The efficiency of moving the load from point A to point B is 94%.

$$3000/3192 * 100\% = 94\%$$

Question 2c.

Marks	0	1	2	Average
%	97	1	2	0.1

The mass of the load is 100 kg.

$$\text{Energy} = mgh = Fd$$

As the distance is equal to the height, $F = mg$ or ma

Height is 3 so force is equal to $3000/3 = 1000 \text{ N}$

$$\text{Using } F = ma, 1000 = m \times 10$$

$$m = 100 \text{ kg.}$$

Question 3a.

Marks	0	1	2	3	4	Average
%	28	19	12	12	27	1.9

The expected readings on the voltmeter, V, and the ammeters, A_1 and A_2 , are as follows:

$$R_T = 120$$

$$\Rightarrow I_{(A1)} = 30/120 = 0.25 \text{ A}$$

$$I_{(A2)} = 0 \text{ A}$$

$$V = 15 \text{ V (half V source)}$$

Question 3b.

Marks	0	1	2	3	Average
%	72	3	12	14	0.7

The faulty component is the resistor R_1 , which becomes an open circuit.

Question 3c.

Marks	0	1	2	3	Average
%	76	14	4	6	0.4

The power dissipated by resistor R_1 with the switch closed is 1.65 W.

$$R_T = 90 \Omega \text{ (60 + two 60 } \Omega \text{ resistors in parallel)}$$





$$I_{(A1)} = 30/90 = 0.33 \text{ A}$$

$$I_{(A2)} = I_{(A1)} / 2 = 0.165 \text{ A}$$

$$P = V \cdot I = 10 \cdot 0.165 = 1.65 \text{ W}$$

Question 4

Marks	0	1	2	3	Average
%	19	46	25	9	1.3

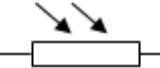
battery 	PNP transistor 	variable DC power supply 
capacitor 	light-emitting diode 	light-dependent resistor 

Question 5a.

Marks	0	1	2	Average
%	71	17	13	0.4

The super capacitor would be best suited for this application as it possesses a very high capacitance level.

Question 5b.

Marks	0	1	2	Average
%	32	27	41	1.1

The purpose of the resistor is to limit the flow of the current through the LED, which prevents the LED from overheating.

Question 6a.

Marks	0	1	2	Average
%	48	30	23	0.7

The variable resistor affects the output voltage V_{out} for a given temperature and controls the internal temperature of the fridge (e.g. sets temperature inside the fridge).

Question 6b.

Marks	0	1	Average
%	35	65	0.6

The ammeter could be located anywhere in the circuit so long as the ammeter is in series.

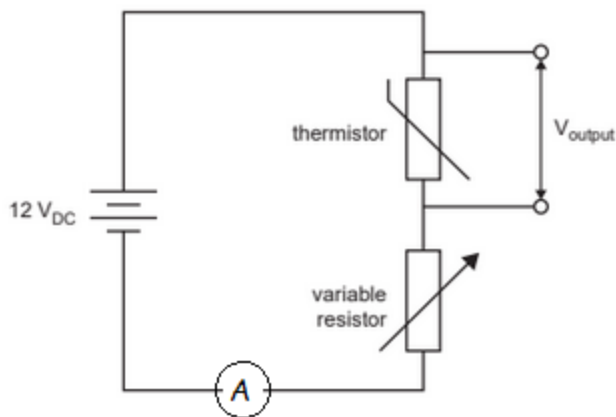

Question 6c.

Marks	0	1	2	3	4	Average
%	37	15	16	18	13	1.6

The power consumed by the variable resistor is 64 mW.

$$V_{RV} = 12 - 4 = 8 \text{ V}$$

$$I = V/R = 8/1000$$

$$\Rightarrow I = 0.008 \text{ A or } 8 \text{ mA}$$

$$P = VI = 8 \times 0.008 = 0.064 \text{ W or } 64 \text{ mW}$$

Question 7a.

Marks	0	1	2	Average
%	19	21	60	1.4

Many valid answers were given including the following:

- Ben needs to test and trial possible solutions for his design brief
- to determine the functionality and performance of the robot subsystem
- to identify potential components and materials required.

Question 7b.

Marks	0	1	2	Average
%	18	18	64	1.5

One appropriate diagnostic test and explanation could be:

- Test the motor for sufficient torque by using 'test' weights for the winch to ensure that the motor provides sufficient torque and/or the sprocket gears provide sufficient mechanical advantage to retrieve the injured child.

Question 7ci.

Marks	0	1	Average
%	14	86	0.9

Evaluation is a continual process and is done at all steps. A final evaluation of the system occurs after production.

Question 7cii.

Marks	0	1	Average
%	31	69	0.7

Ben should evaluate his rescue robot subsystem when he wants to determine how successful the rescue robot performed in relation to the problem identified in his design brief.

Question 8a.

Marks	0	1	Average
%	65	35	0.4

The wind turbines typically produce AC (alternating current).

Question 8b.

Marks	0	1	2	Average
%	19	39	42	1.2

Any two of the following:

- taller turbine towers
- larger turbine blades
- adjustable angle of attack
- adjustable pitch angle
- use of an upstream deflector.

Question 8c.

Marks	0	1	2	Average
%	13	25	62	1.5

One of the following:

- allows designers to observe the flow of air around the blade
- allows designers to analyse possible solutions prior to construction.

Question 9a.

Marks	0	1	Average
%	62	38	0.4

One possible robotic pool cleaner process is heat from the motors or transformer. Other valid answers were accepted.

Question 9b.

Marks	0	1	2	Average
%	39	4	57	1.2

The overall efficiency of the robotic pool cleaner system is 82.5%.

$$[(1000 + 650)/2000] * 100 = 82.5\%$$

Question 10a.

Marks	0	1	Average
%	86	14	0.1

One advantage of using the worm drive as the initial input is to allow the steering wheel to be the only input. The spur gear cannot be driven.

Question 10b.

Marks	0	1	Average
%	61	39	0.4

The gearbox ratio is driven:driver = 7:1

Question 10c.

Marks	0	1	2	3	4	Average
%	42	19	6	4	28	1.6

The force at point A on the steering arm is 80 N.

$$F_1 d_1 = F_2 d_2$$

$$F_2 = (F_1 \times d_1) / d_2$$

$$F_2 = (200 \times 0.1) / 0.25$$

$$= 80 \text{ N}$$

Question 11a.

Marks	0	1	Average
%	46	54	0.5

Should the car become stuck, a rubber band belt drive system would:

- allow slip and not burn the motor out
- make it easy to engage or disengage.

Question 11bi.

Marks	0	1	2	Average
%	71	8	21	0.5

The expected speed of the small electric motor-driven car would be 9.42 metres per minute.

$$\text{Speed} = \text{Circumference} \times 40$$

$$= \pi \times 0.075 \times 40$$

$$= 9.42 \text{ m min}^{-1}$$

Question 11bii.

Marks	0	1	Average
%	44	56	0.6

The question required students to convert metres per minutes to metres per second.

$$9.42/60 = 0.157 \text{ m s}^{-1}$$

Question 11c.

Marks	0	1	Average
%	55	45	0.5

One of the following:

- increase the diameter of the drive pulley on the motor
- increase the motor rpm.

Question 12a.

Marks	0	1	2	Average
%	25	43	32	1.1

Friction allows the transfer of movement from the belt to the drive wheel. Without friction the belt would slip on the drive wheel and the wheel would not turn.

Question 12b.

Marks	0	1	2	Average
%	36	12	52	1.2

The rotation speed of the motor wheel for the drive is 1350 rpm.

Pulley A rpm / pulley B rpm = radius B/radius A

motor wheel rpm/150 = 900/100

motor wheel rpm = 150 × 900/100

= 1350 rpm

Question 12c.

Marks	0	1	2	3	Average
%	18	7	19	55	2.1

As the motor rotates, the motor wheel rotates, which moves the belt drive, which rotates the drive wheel and the drive shaft. The crankshaft is connected to the edge of the pulley on the drive shaft. As the drive shaft rotates, the end of the crankshaft is moved in a circle with some up/down motion and some left/right motion. The linear bearings hold the needle bar vertical so only up/down or reciprocating motion is transferred to the needle bar and the needle.

Question 13a.

Marks	0	1	Average
%	38	62	0.6

The tip truck's tray is a Class 2 lever.

Question 13b.

Marks	0	1	2	3	Average
%	41	26	22	11	1.0

Below a certain angle, the force of friction is equal to the component of gravity along the tray bed. As the tray bed angle is increased, the component of gravity in the direction of the tray bed increases. According to Newton's First law, when the force of gravity is greater than the force of friction in the direction of the tray bed the box will accelerate.

Question 13c.

Marks	0	1	2	Average
%	46	31	23	0.8

The pressure needed to create the 6000 N force is 122 kPa.

$$P = F/A$$

$$P = 6000/(\pi \times 0.125^2)$$

$$P = 122 \text{ kPa}$$

Question 13d.

Marks	0	1	2	Average
%	26	65	9	0.8

Both points B and C are under compression.

Question 14

Marks	0	1	2	3	Average
%	30	10	16	44	1.8

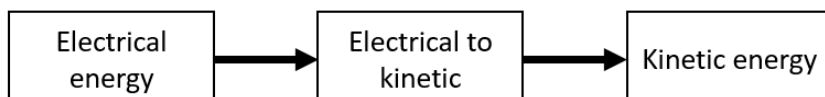

Question 15

Marks	0	1	2	3	4	5	Average
%	16	5	14	25	28	13	2.8

Both the benefits and challenges of using electric vehicles needed to be addressed in terms of economic and environmental sustainability. Some reference to Australian conditions, such as large distances or low population density, were needed.

Benefits could include:

- lower maintenance costs of EV over petrol driven vehicles
- less noise pollution
- reduced air pollution/greenhouse gas emissions.

Challenges could include:

- upfront cost of purchasing an EV
- disposal of batteries
- lack of sufficient infrastructure
- charging times.