



# Victorian Certificate of Education 2012

SUPERVISOR TO ATTACH PROCESSING LABEL HERE

## STUDENT NUMBER

Letter

Figures

Words

# VCE VET ENGINEERING STUDIES

## Written examination

Wednesday 21 November 2012

Reading time: 9.00 am to 9.15 am (15 minutes)

Writing time: 9.15 am to 10.45 am (1 hour 30 minutes)

## QUESTION AND ANSWER BOOK

### Structure of book

<i>Section</i>	<i>Number of questions</i>	<i>Number of questions to be answered</i>	<i>Number of marks</i>
A	15	15	15
B	4	4	15
C	3	3	15
D	7	7	15
E	5	5	40
			Total 100

- Students are permitted to bring into the examination room: pens, pencils, highlighters, erasers, sharpeners, rulers, a protractor, a set square and aids for curve sketching.
- Students are NOT permitted to bring into the examination room: blank sheets of paper and/or white out liquid/tape.
- A scientific calculator is allowed in this examination.

### Materials supplied

- Question and answer book of 30 pages.
- Answer sheet for multiple-choice questions.

### Instructions

- Write your **student number** in the space provided above on this page.
- Check that your **name** and **student number** as printed on your answer sheet for multiple-choice questions are correct, **and** sign your name in the space provided to verify this.
- All written responses must be in English.

### At the end of the examination

- Place the answer sheet for multiple-choice questions inside the front cover of this book.

**Students are NOT permitted to bring mobile phones and/or any other unauthorised electronic devices into the examination room.**

**SECTION A – VBN 771 Apply electrotechnology principles in an engineering work environment****Instructions for Section A**

Answer **all** questions in pencil on the answer sheet provided for multiple-choice questions.

Choose the response that is **correct** or that **best answers** the question.

A correct answer scores 1, an incorrect answer scores 0.

Marks will **not** be deducted for incorrect answers.

No marks will be given if more than one answer is completed for any question.

**Question 1**

An industrial complex has a 2.2 kV electrical supply.

This is equal to

- A. 220 volts.
- B. 2 200 volts.
- C. 22 000 volts.
- D. 220 000 volts.

**Question 2**

What type of meter is used to measure electrical energy?

- A. ammeter
- B. voltmeter
- C. ohmmeter
- D. wattmeter

**Question 3**

Which one of the following materials is classified as a good insulator of current?

- A. PVC
- B. carbon
- C. copper
- D. bronze

**Question 4**

In a simple circuit, the purpose of the battery is to

- A. disconnect the circuit when it is not required to operate.
- B. prevent overheating of the conductors.
- C. provide a safe voltage for the circuit.
- D. consume electricity usefully.

**Question 5**

If the two terminals of a battery are connected by a wire

- A. a short circuit is created.
- B. a closed circuit is created.
- C. an open circuit is created.
- D. a normal circuit is created.

**Question 6**

Which of the following is an example of the practical use of the **magnetic effect** of an electric current?

- A. LED
- B. strip heater
- C. electric motor
- D. incandescent globe

**Question 7**

**Figure 1**

What does the electrical symbol shown in Figure 1 represent?

- A. neutral wire
- B. negative terminal
- C. earth connection point
- D. active connection point

Use Figure 2 to answer Questions 8 and 9.

### Question 8

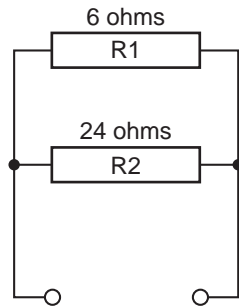

**Figure 2**

The circuit in Figure 2 is commonly referred to as a

- A. series circuit.
- B. parallel circuit.
- C. series/parallel circuit.
- D. parallel/series circuit.

### Question 9

In Figure 2, which of the following statements is correct?

- A. The voltage drop across R1 is equal to the voltage drop across R2.
- B. The voltage drop across R1 is greater than the voltage drop across R2.
- C. The voltage drop across R2 is greater than the voltage drop across R1.
- D. There is not enough information to determine the relationship between the voltage drops.

### Question 10

A portable 12-volt battery charger appears not to be working. The output leads have been tested for voltage and the reading was zero volts.

The next step should be to

- A. cut the wires to the outlet.
- B. test the meter to check if it is working.
- C. remove any fuses from the equipment.
- D. carefully remove the covers and inspect for equipment damage.

### Question 11

Before handling capacitors or working on circuits where capacitors are used, the correct procedure is to

- A. touch all the terminals.
- B. charge the capacitors fully.
- C. test the capacitors with an ohmmeter.
- D. discharge the capacitors fully.

**Question 12**

Wire-wound resistors have a higher wattage rating than carbon resistors because they are usually required to dissipate more

- A. heat.
- B. light.
- C. current.
- D. voltage.

**Question 13**

Before using a multimeter to take measurements, always check that you have selected the correct

- A. type and make.
- B. leads and brand.
- C. function and range.
- D. colour and connection.

**Question 14**

What is a typical application for a solar cell?

- A. electroplating
- B. charging batteries
- C. powering microwave ovens
- D. measuring high levels of temperature

**Question 15**

A 240-volt power angle grinder draws a current of 8 amps.

Its resistance is

- A. 0.33 ohm.
- B. 30 ohms.
- C. 192 ohms.
- D. 1920 ohms.

**SECTION B – VBN 773 Produce basic engineering sketches and drawings****Instructions for Section B**

Answer **all** questions in the spaces provided. All dimensions are in mm (millimetres).

Figure 1 shows an isometric view of a clamp.

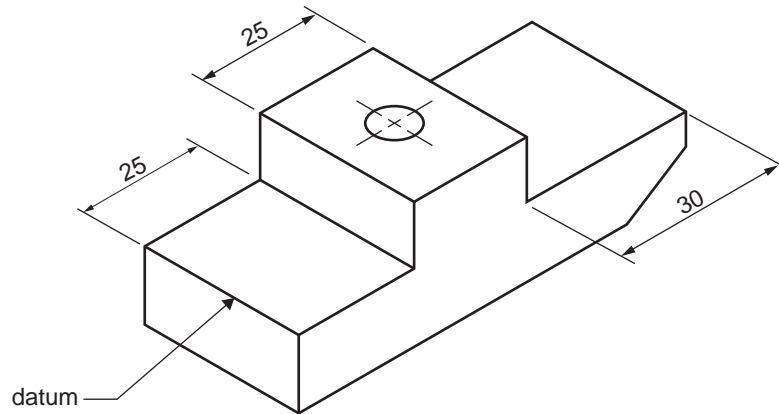
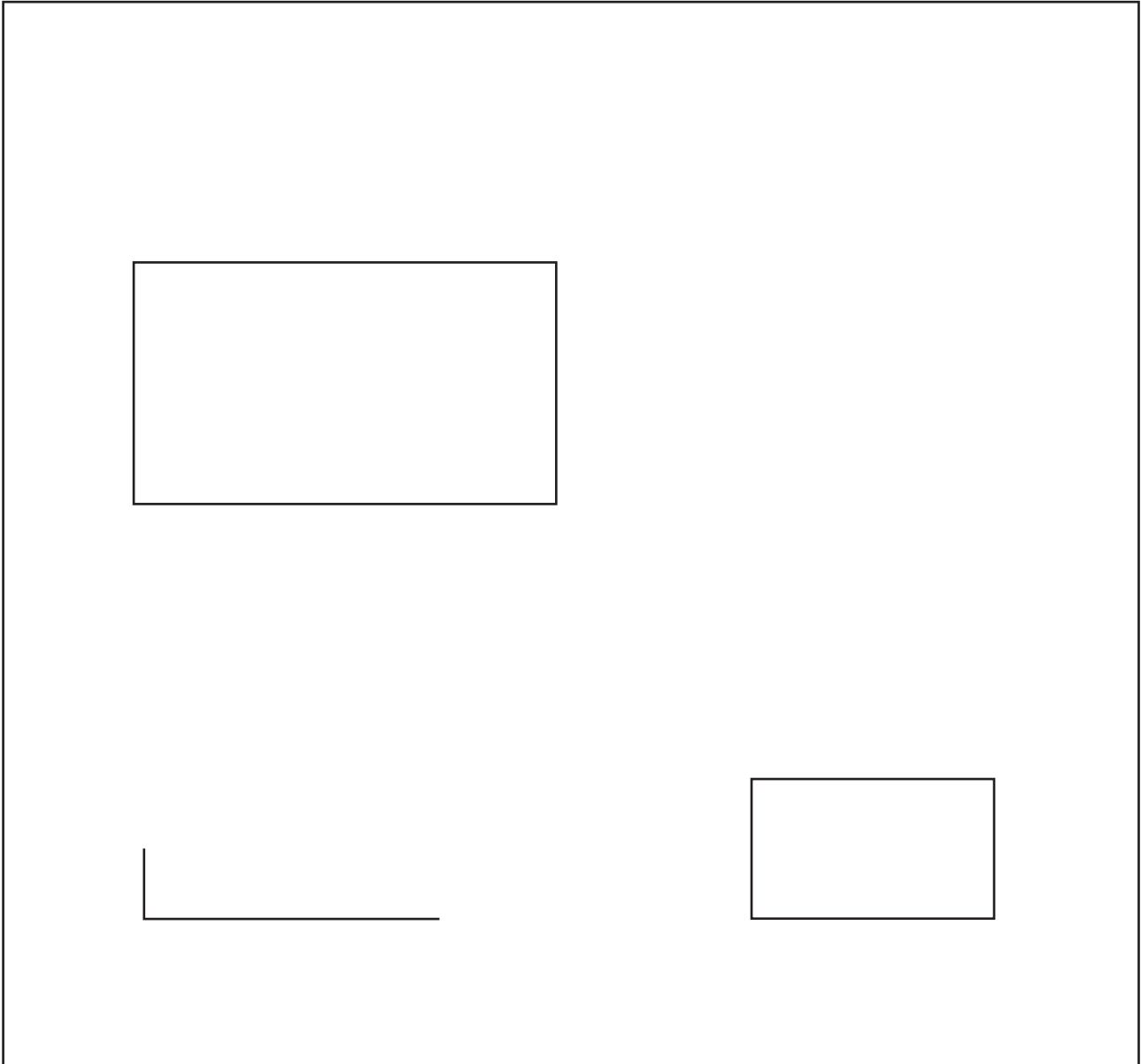

**Figure 1**

**Question 1**

On the sketch below complete the top, side and end views of the clamp shown in Figure 1.

- Use conventional drawing systems.
- Show views in third-angle projection.
- Show all hidden detail.
- Dimension the three lengths from the **datum**, not as shown in Figure 1.



6 marks

**Question 2**

Figure 2 shows a bracket.

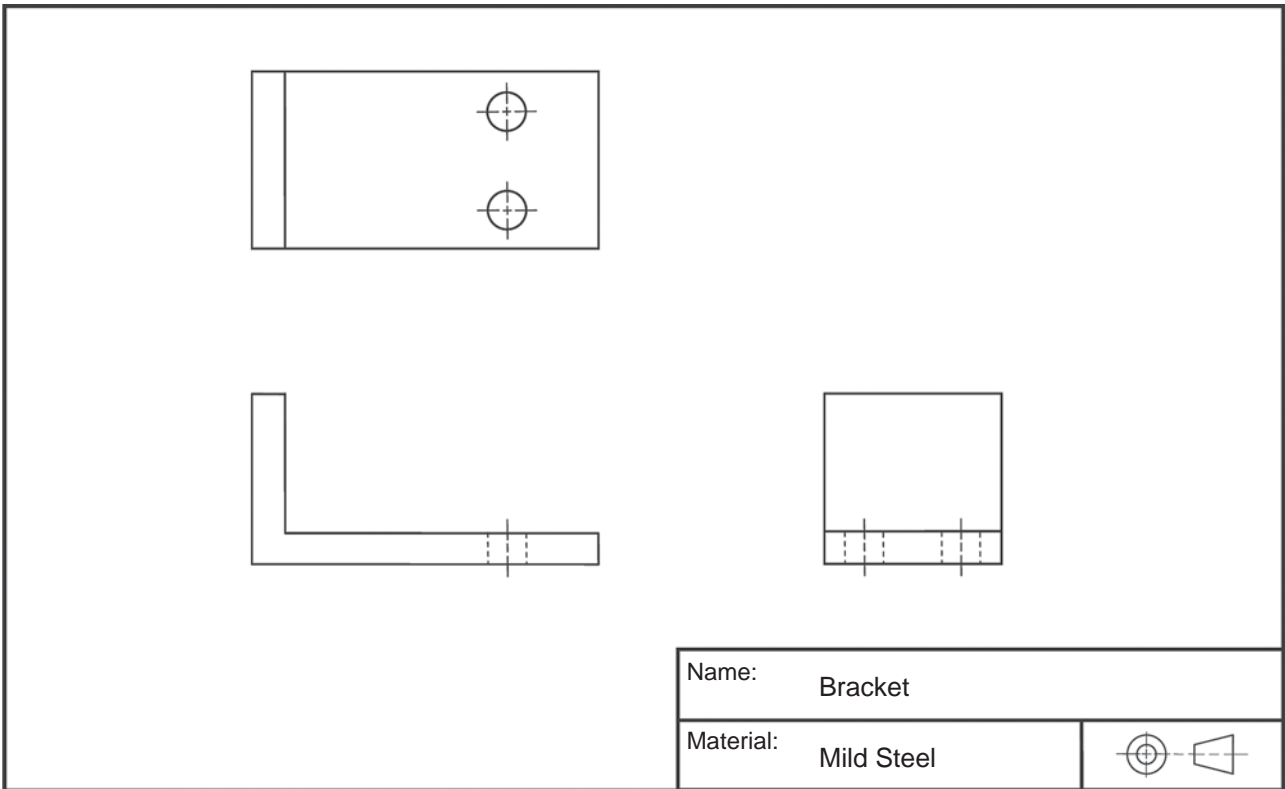

**Figure 2**

In the space provided below, sketch an isometric view of the bracket shown in Figure 2.

**Do not dimension the drawing.**

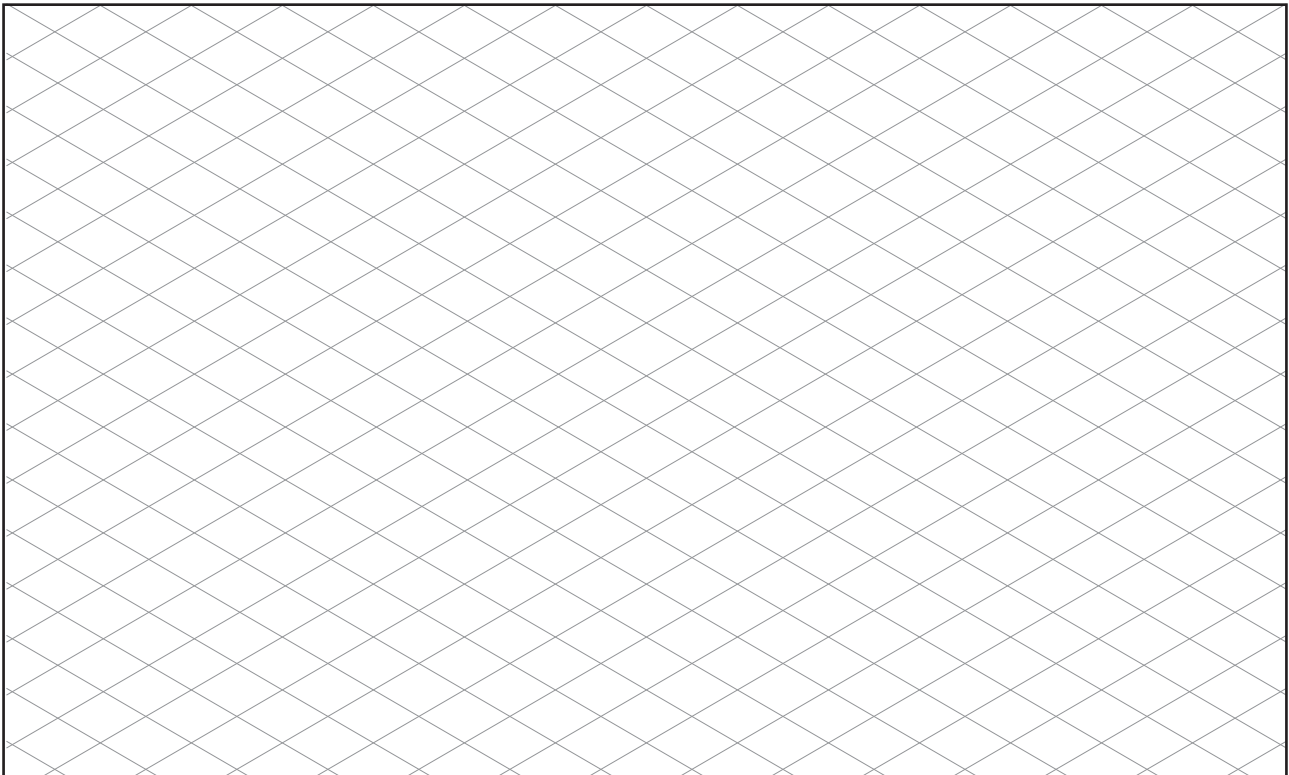

3 marks



**Question 3**

Figure 3 below shows a threaded shaft.

Complete the sketch below to show the six missing features.

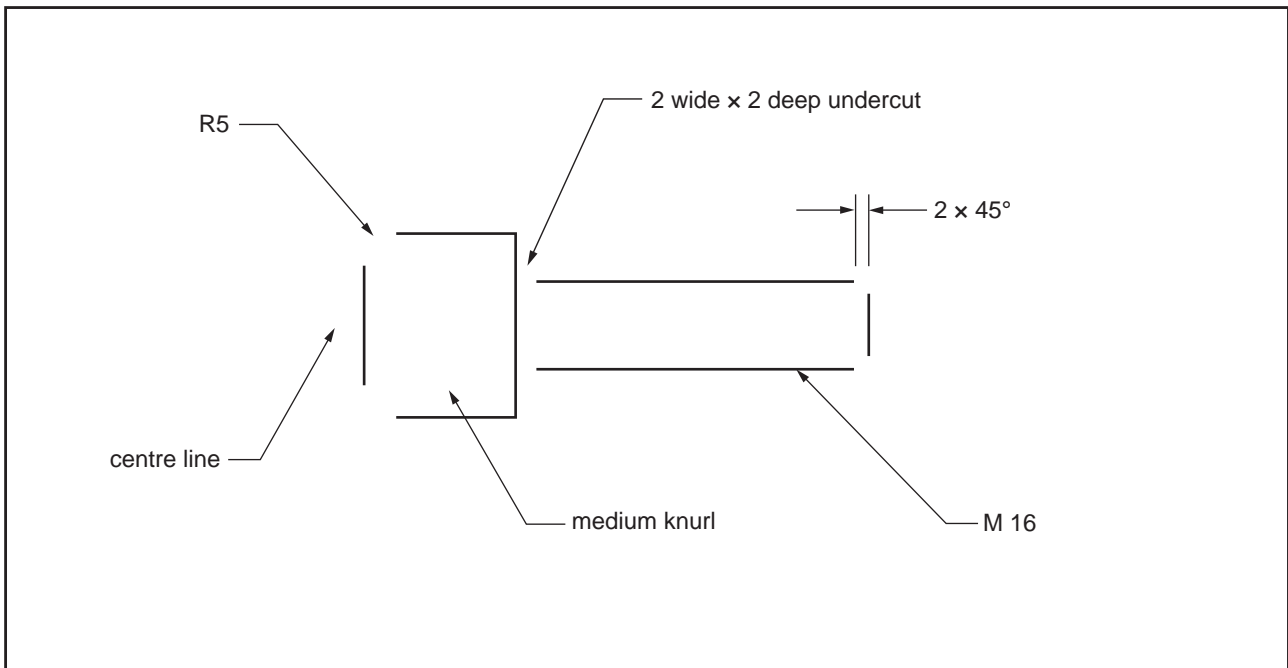
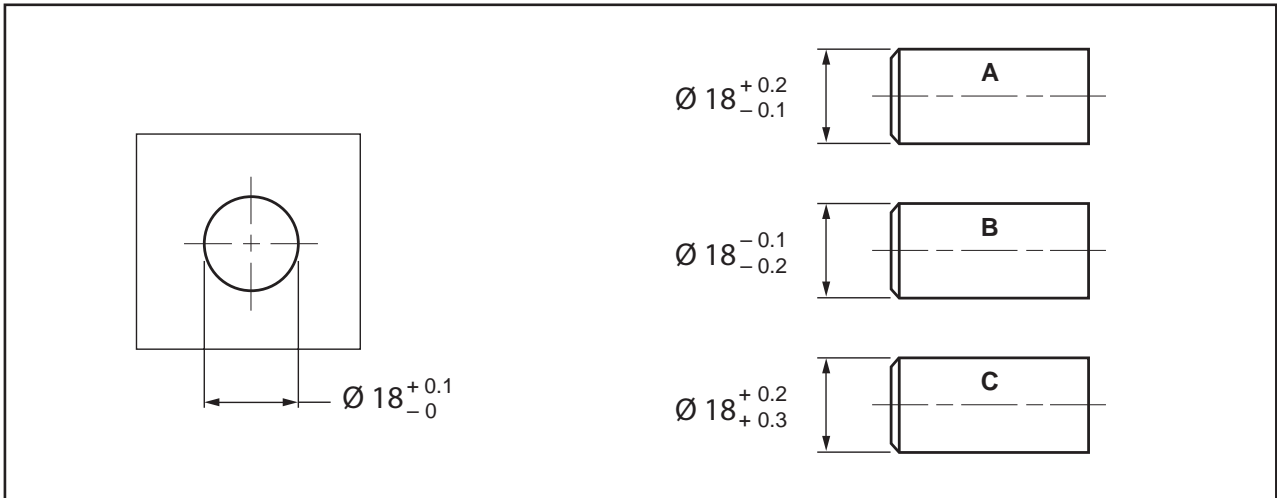

**Figure 3**

3 marks

**Question 4**

Figure 4 shows a plate with a hole and three shafts. The shafts have different tolerances, which will result in different fits.



**Figure 4**

- a. What are the maximum and minimum sizes that are allowed for the hole in Figure 4?

maximum \_\_\_\_\_

minimum \_\_\_\_\_

1 mark

- b. Which shaft in Figure 4 will **not fit** the hole?

1 mark

- c. Which shaft in Figure 4 will always be a **loose fit** in the hole?

1 mark

**SECTION C – VBN 776 Use basic engineering concepts to plan the manufacture of engineering components**

**Instructions for Section C**

Answer **all** questions in the spaces provided. All dimensions are in mm (millimetres).

Figure 1 shows a sketch of a set of car stands. All the questions in this section relate to these car stands.

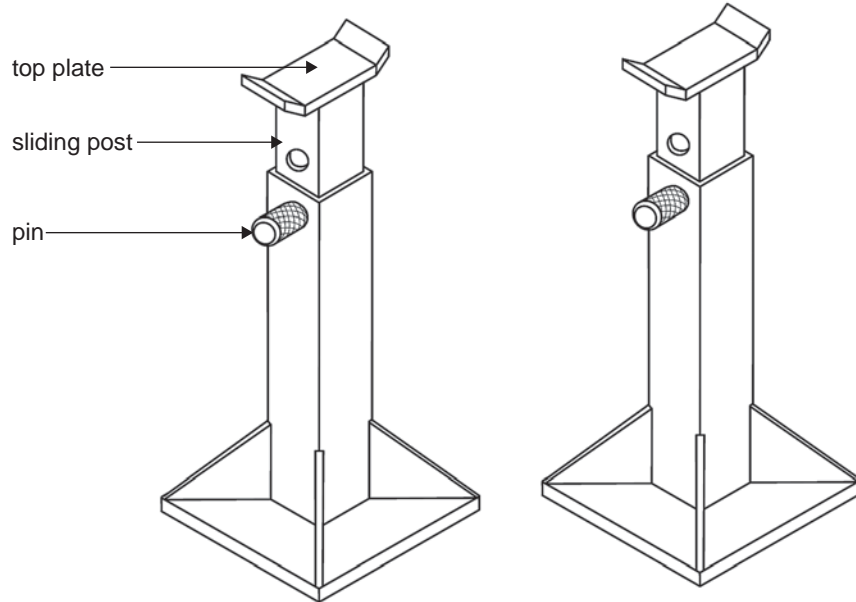

**Figure 1**

Figure 2 shows a detailed drawing of the sliding post from the car stands.

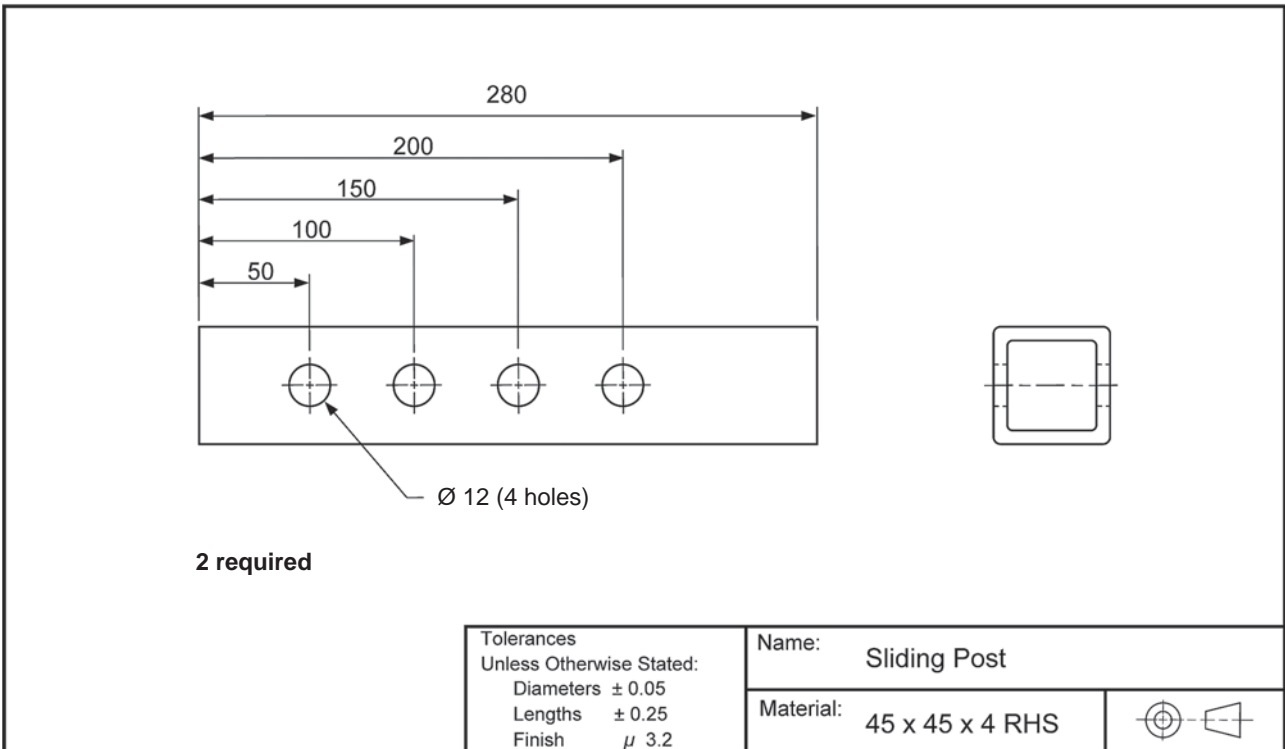
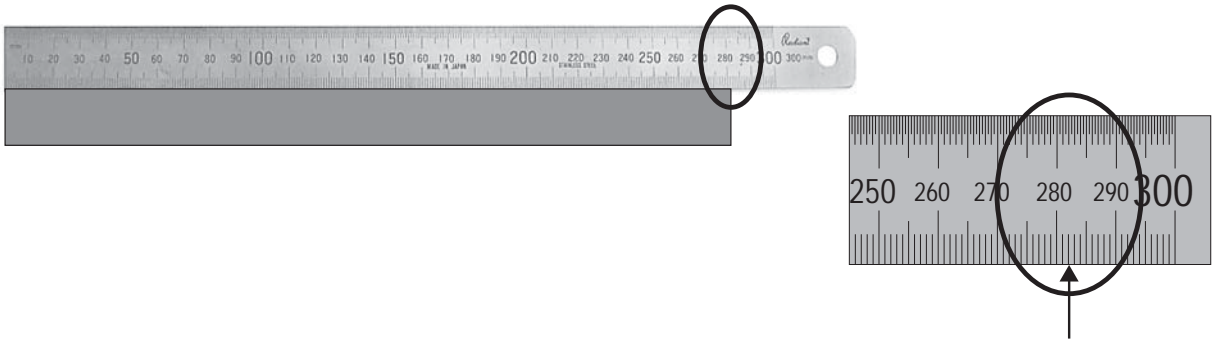

**Figure 2**

**Question 1**

The material for each sliding post has been cut longer than required so the ends can be squared.

a. How long is the material?



\_\_\_\_\_

1 mark

b. Describe **two** ways that the ends can be squared off.

\_\_\_\_\_  
\_\_\_\_\_

2 marks

c. From the tools shown below, name four tools that you would use to mark out the holes in the sliding post.



1. \_\_\_\_\_
2. \_\_\_\_\_
3. \_\_\_\_\_
4. \_\_\_\_\_

2 marks

Figure 3 shows a detailed drawing of the pin from the car stands.

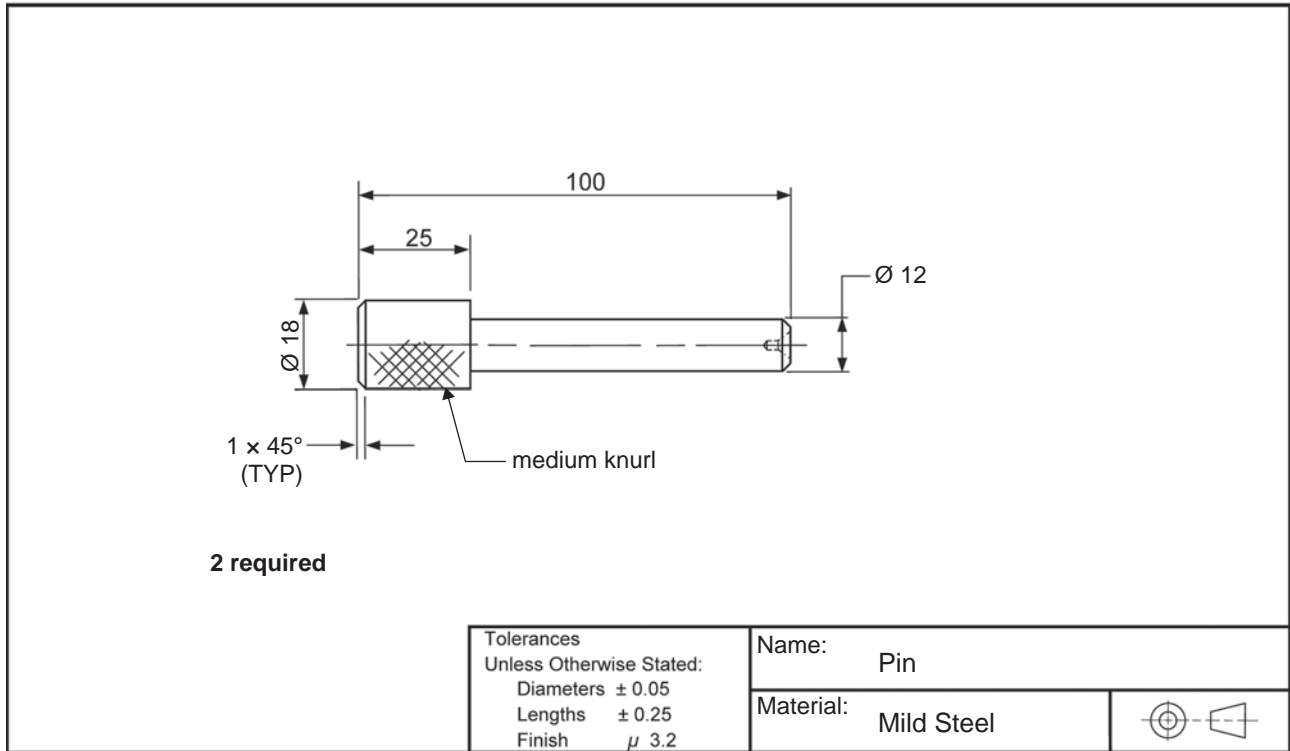

Figure 3

### Question 2

The pin shown in Figure 3 will be made on a lathe from a 500 mm length of  $\text{Ø } 20$  mild steel bar. When most of the turning and knurling have been completed, it will be parted off from the 500 mm bar, faced to length and chamfered.

a. List four tools needed to make the pin on the lathe.

1. \_\_\_\_\_
2. \_\_\_\_\_
3. \_\_\_\_\_
4. \_\_\_\_\_

2 marks

- b. Complete the sequence of operations that will be required to make the pin shown in Figure 3.

<b>Step</b>	<b>Operation</b>
1	Face and centre drill bar
2	Re-position 120 mm out of chuck and support with live centre

5 marks

Figure 4 shows a detailed drawing of the car stand's top plate. The drawing is incomplete because it is missing two measurements.

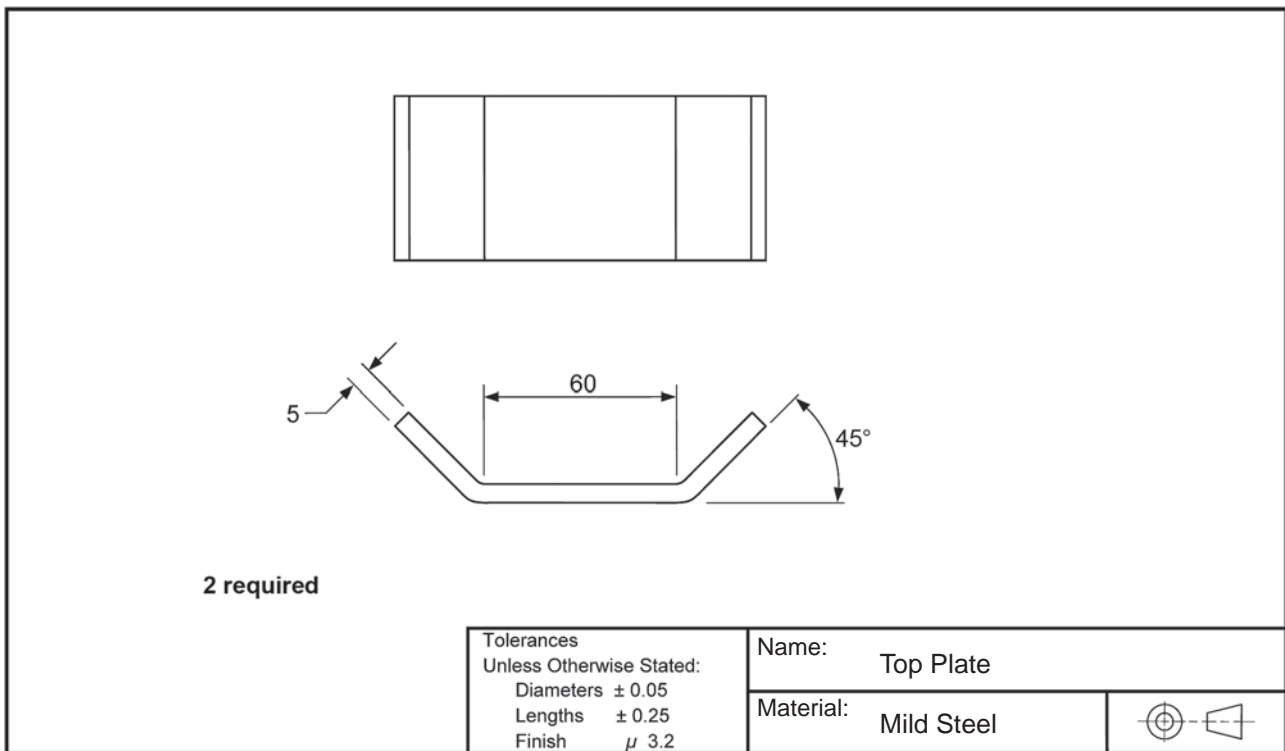

**Figure 4**

**Question 3**

a. Indicate on the drawing in Figure 4 the two missing measurements.

2 marks

b. Describe how to bend the 45° angles.

---



---

1 mark

## SECTION D – VBN 777 Handle engineering materials

### Instructions for Section D

Answer **all** questions in the spaces provided.

Figure 1 shows an extract from the ‘Summary of the *Occupational Health and Safety (OH&S) Act 2004*’.

### GENERAL OHS DUTIES

**Duties of employers to employees and contractors (S21)**

The Act requires all employers to provide and maintain a working environment that is safe and without risks to health.

Employers owe the same duty to independent contractors and their employees who are working at the workplace, but only for matters over which the employer has, or should have, control.

The Act sets out specific duties that employers must comply with as part of their general duty. These include:

- A** { • providing and maintaining plant and systems of work that are safe and do not pose health risks (e.g. providing effective guards on machines and regulating the pace and frequency of work);
- B** { • making arrangements to ensure the absence of risks to health and safety connected with the use, handling, storage and transport of plant or substances (e.g. toxic chemicals, dusts and fibres);
- C** { • maintaining workplaces under their management and control in a condition that is safe and without health risks (e.g. controlling noise and lighting levels);
- D** { • providing adequate facilities for the welfare of employees at workplaces under their management and control (e.g. washrooms, lockers and dining areas); and
- E** { • providing employees with information, instruction, training or supervision needed for them to work safely and without risks to their health\*\*.

An employer must provide their employees with health and safety information in languages appropriate for their employees, including the name of any person to whom employees may make an enquiry or complaint about health or safety.

**Duties of employers to monitor health and safety conditions (S22)**

Employers must:

- monitor the health of their employees and the conditions of the workplaces under their management and control;
- keep records on the health and safety of their employees; and
- employ or engage the services of a person suitably qualified in OHS to provide advice on the health and safety of their employees.

**Duties of employers and self-employed to other people (S23 & 24)**

Employers and the self-employed must ensure that the health and safety of members of the public is not adversely affected by their business activities. This duty includes matters such as protecting visitors to a workplace, protecting the general public from construction or demolition work being done near roads and footpaths, and preventing the emission of hazardous substances from a workplace.

**Duties of employees (S25)**

- F** { While at work, employees are required to take reasonable care for their own safety and the safety of others who may be affected by their actions or omissions\*\*. They must also cooperate with any actions taken by their employer to comply with the Act and regulations\*\*.
- G** { An employee must not intentionally or recklessly interfere with or misuse anything provided at the workplace in the interests of health, safety and welfare\*\*.

**Duties of those who manage or control workplaces (S26)**

Any person or body that manages or controls a workplace, to any extent, must ensure that the workplace, including entering and exiting the workplace, is safe and without risk to health. This duty is limited to matters over which the person has management or control.

Those who manage or control a workplace could include the employer, the occupier of the workplace, the owner of the workplace and others.

*Note: The general OHS duties under the Act are all duties to be met ‘so far as is reasonably practicable’ with the exception of those marked \*\*.*

---

WORKSAFE VICTORIA / SUMMARY OF THE OCCUPATIONAL HEALTH AND SAFETY ACT 2004 7

Figure 1



**Question 1**

This question refers to the summary of the *OH&S Act* that is shown in Figure 1.

Some of the paragraphs have been labelled (A–G).

- a. Which paragraph in the summary of the *OH&S Act* tells employers that they must keep machines and equipment in a safe working condition?

1 mark

- b. Which paragraph in the summary of the *OH&S Act* states that an employee must not do anything that will endanger another employee?

1 mark

- c. An employer provides you with PPE on the job. What are your duties as an employee?

---

1 mark

**Question 2**

**Figure 2**

You are handling materials where the sign in Figure 2 is displayed. Apart from overalls and safety boots, list **two** specific items of PPE that you would need to wear.

---



---

2 marks

**Question 3**

List **two** safety-related items of information that are usually found in a Material Safety Data Sheet (MSDS).

---



---

2 marks

**Question 4**

Below are three commonly used manual lifting aids.

1.



2.



3.



Select the most suitable lifting aid (1., 2. or 3.) for each of the three activities described below.



Move a vice from a storage rack to a milling machine table.



Move a timber crate from one end of the workshop to the other.



Move a pallet of boxes from the workshop to the warehouse.

3 marks

**Question 5**

Figure 3 shows a person who is removing a heavy box from the top of a cupboard. This example of manual handling is unsafe and could result in injuries to the body.



**Figure 3**

List **two** injuries that could occur from the manual handling shown in Figure 3.

---

---

2 marks

**Question 6**

Figure 4 shows a person who is carrying a length of steel pipe through a workshop.



**Figure 4**

Describe the main hazard in this photo.

---

---

1 mark

**Question 7**

Figure 5 shows a person who is lifting a piece of metal plate out of a rack.



**Figure 5**

Describe **two** hazards that are associated with the lifting shown in Figure 5.

---

---

2 marks

**CONTINUES OVER PAGE**

**TURN OVER**

**SECTION E – VBN 778 Produce basic engineering components and products using fabrication and machining**

**Instructions for Section E**  
 Answer **all** questions in the spaces provided. All dimensions are in mm (millimetres).

Figure 1 shows an assembly drawing of a tool trolley.

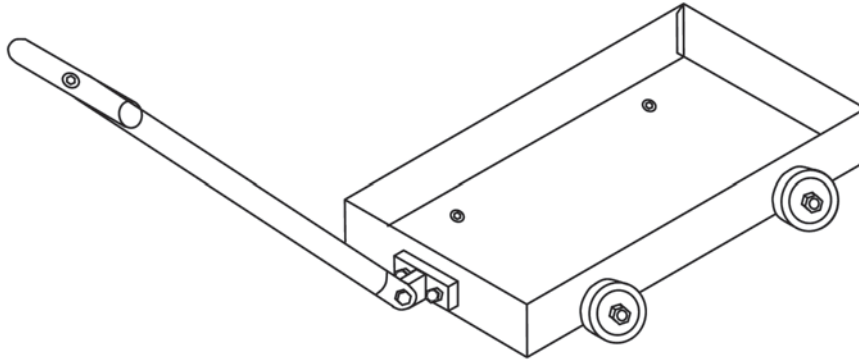

**Figure 1**

Figure 2 shows a detailed drawing of the base of the tool trolley.

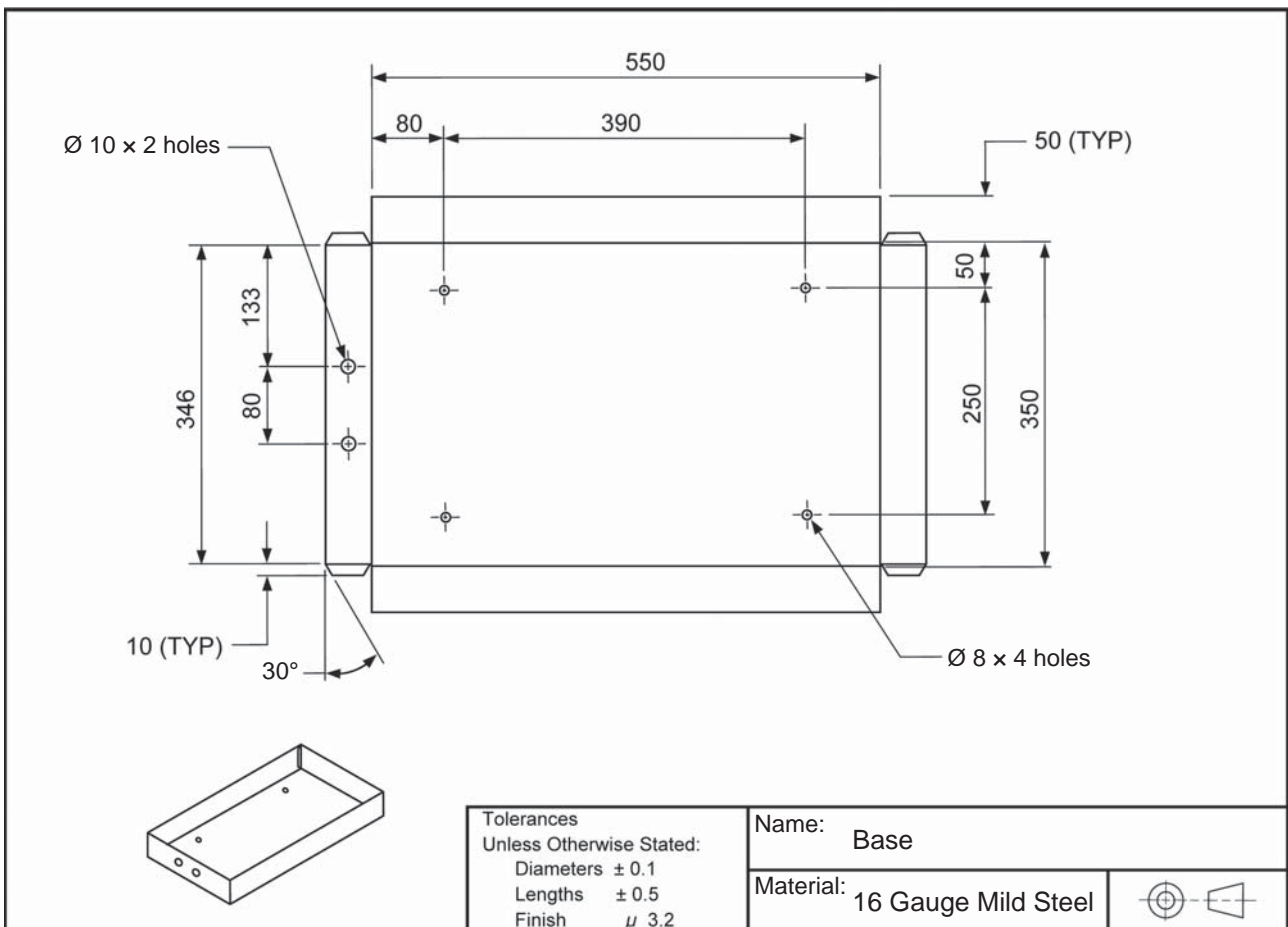

**Figure 2**

**Question 1**

- a. What material is the base made from?

---

1 mark

- b. In order to make the base, the material needs to be cut from a larger sheet.  
What size should it be cut to?

---

1 mark

- c. Describe how to check the base for squareness after it has been cut.

---

1 mark

The tool that is shown in Figure 3 will be used to mark out part of the base.

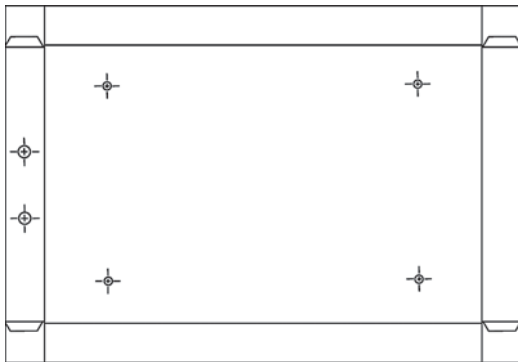

**Figure 3**

- d. i. What is the name of the tool that is shown in Figure 3?

---

- ii. Show on Figure 4 the lines that will be marked out using this tool.



**Figure 4**

1 + 1 = 2 marks

- e. List **two** methods that can be used to cut away the corners of the base before bending.

---



---

2 marks

When all the bending has been completed, the corners of the base will be joined together, as indicated in Figure 5.

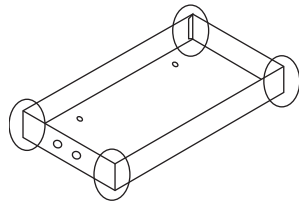

**Figure 5**

f. List three different ways that the corners can be joined together.

1. \_\_\_\_\_
2. \_\_\_\_\_
3. \_\_\_\_\_

3 marks

Figure 6 shows a detailed drawing of the axle from the tool trolley.

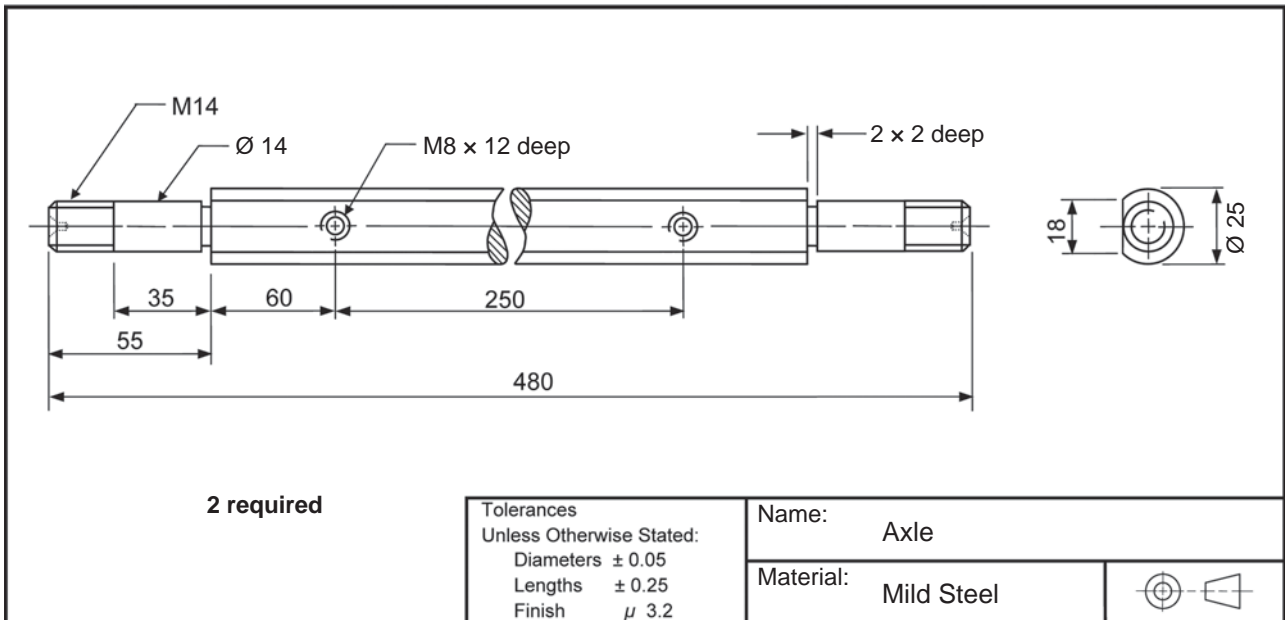

**Figure 6**

**Question 2**

a. Shown below (A.–F.) are a number of steel bars of different sizes.  
Which size would be most suitable to make the axles?

- |    |    |    |    |    |    |
|----|----|----|----|----|----|
| A. | B. | C. | D. | E. | F. |
|    |    |    |    |    |    |

1 mark



The material for the axle will be set up for machining in the lathe.

- b. What type of chuck will be most suitable for facing and centre drilling?

---

1 mark

Figure 7 shows one of the axles in the lathe. It is being set up for machining.

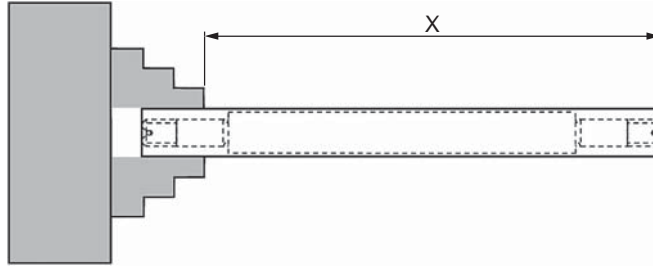

**Figure 7**

The set-up shown in Figure 7 is incomplete.

- c. What needs to be done to complete the set-up before machining? Sketch your answer on Figure 7.

1 mark

- d. What distance (X) should the bar be sticking out to machine the  $\text{\O} 25$ ?

\_\_\_\_\_

1 mark

- e. Name one other work-holding method that can be used to machine the axle in the lathe.

---

1 mark

- f. Calculate the rpm to machine the 25 mm diameter using a cutting speed of 35 m/min ( $\text{rpm} = 320 v/d$ ). Show all working out.

2 marks

The next step is to machine the  $\text{\O} 14$ .

- g. How long does the  $\text{\O} 14$  need to be?

\_\_\_\_\_

1 mark

Below is a cutting tool that is set up at different angles in the lathe.

A.

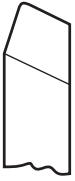

B.



C.



D.

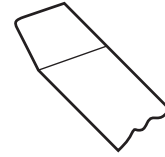

E.

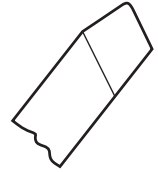

h. i. Which of the angles shown (A.–E.) is correct to finish machining the Ø 14?

ii. Explain why.

---



---

iii. Which part of the lathe needs to be adjusted to obtain the different tool angles that are shown?

---

1 + 1 + 1 = 3 marks

When machining the Ø 14, the surface finish is too rough.

i. List **two** things that can be done to improve the surface finish.

---



---

2 marks

j. Apart from screw cutting on a lathe, what tool can be used to cut the M14 thread?

---

1 mark

The flat will be machined on a vertical milling machine.

k. Name a milling cutter that would be suitable for milling the 18 mm flat.

---

1 mark

l. You want to mill the 18 mm flat so that it is accurate and parallel.

Describe how the axle can be held on the milling machine to achieve this.

---



---

2 marks

After the flat has been milled, the two M8 holes will be drilled and tapped in the **same set-up** on the milling machine.

m. Why would this be better than taking it out of the milling machine, drilling on a pedestal drill and tapping in a bench vice? Give **two** reasons.

---



---

2 marks

Figure 8 shows a detailed drawing of the bracket from the tool trolley.

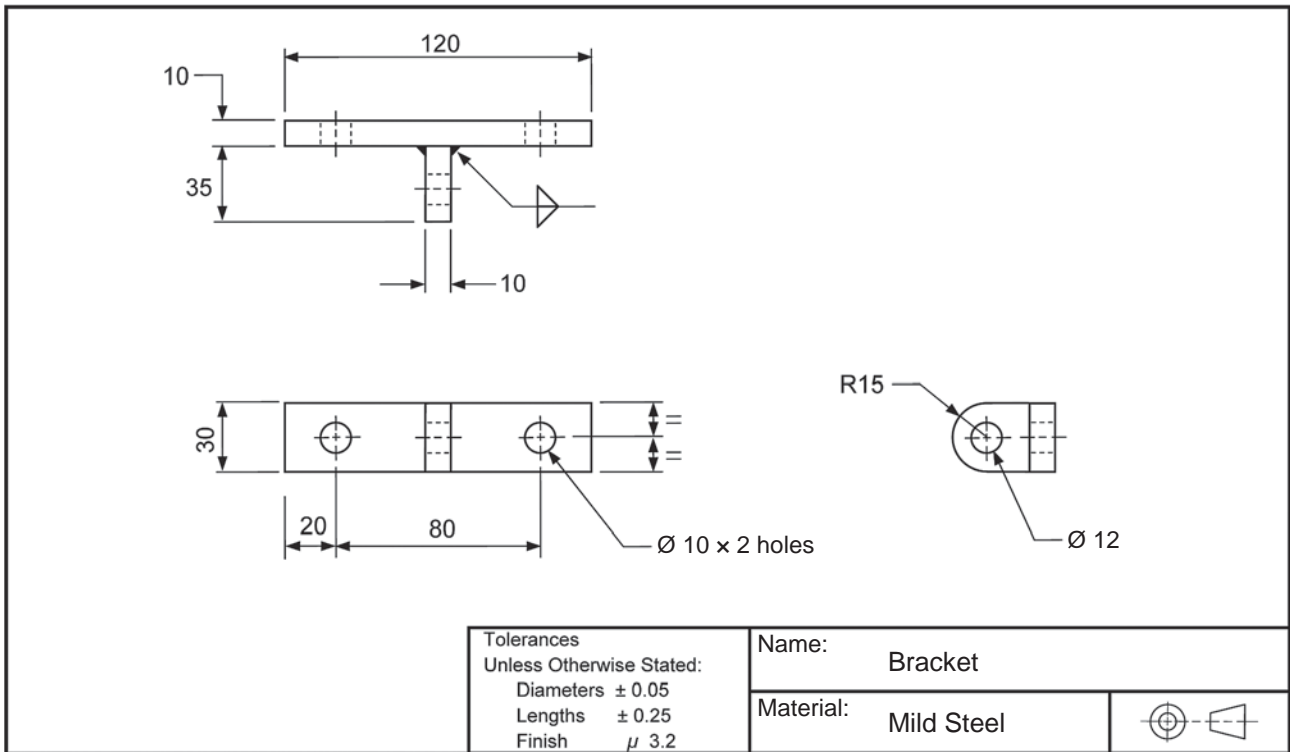

Figure 8

**Question 3**

A hacksaw is being used to cut off the material for the bracket. However, it does not seem to be cutting well.

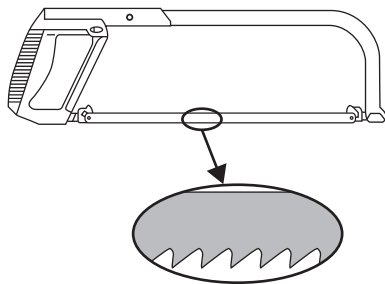

Figure 9

- a. State the main reason why the hacksaw shown in Figure 9 is not cutting well.

\_\_\_\_\_

1 mark

The drawing of the bracket contains the symbol below.



- b. What does this symbol mean?

\_\_\_\_\_

1 mark

- c. What tool would you use to mark out the R15 on the bracket?

---

1 mark

- d. Describe how to make the R15.

---

---

1 mark

Two M10 domed-head screws, similar to the one shown, will be used to fasten the bracket to the base of the trolley.



- e. How long do the screws need to be?

---

1 mark

Figure 10 shows a detailed drawing of the yoke from the tool trolley.

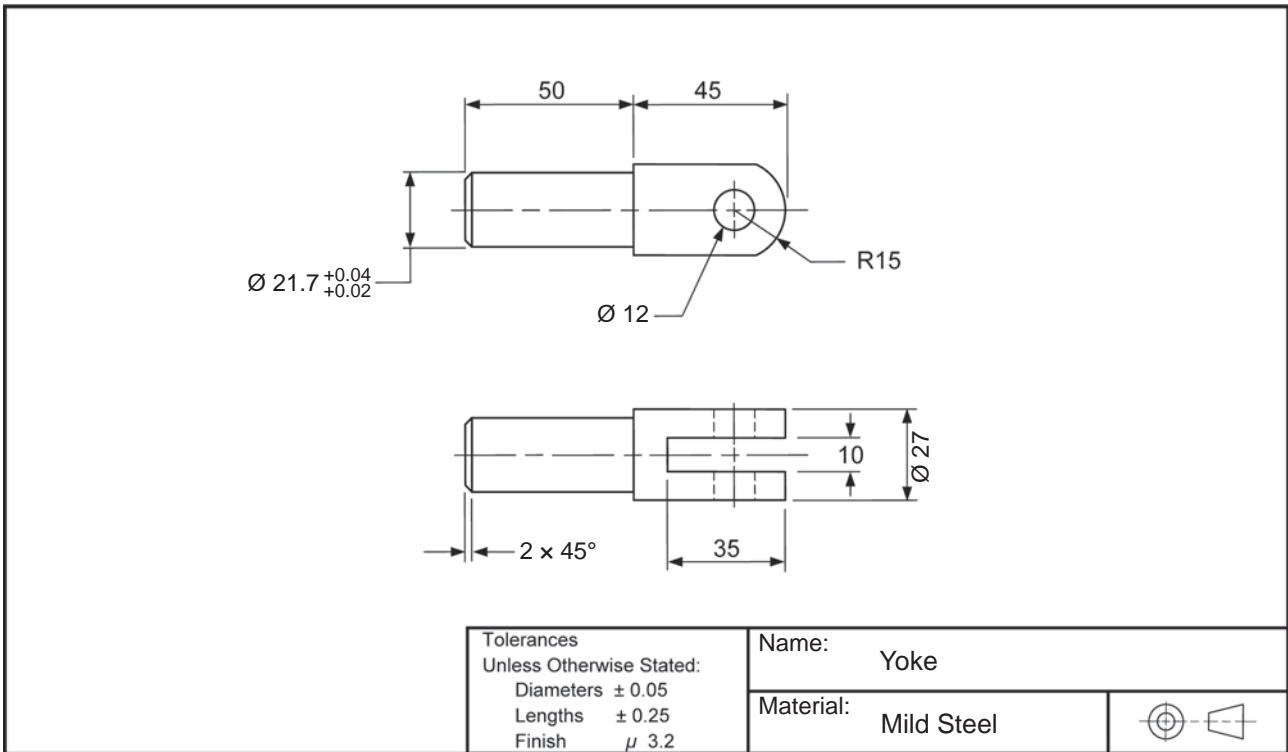

Figure 10

Question 4

a. i. Which of the cutters (A., B. or C.) shown would be most suitable to cut the slot in the yoke?

A. 3 mm slitting saw

B. 10 mm side and face cutter

C. profile cutter



ii. Draw an arrow around the cutter you selected to show the correct direction of rotation.

1 + 1 = 2 marks

b. The  $\text{Ø } 12$  hole in the yoke will be drilled on a pedestal drill.

Describe how the yoke should be held.

1 mark

**Question 5**

A trolley wheel is shown in Figure 11. A plain nut and a plain washer were used to hold the wheels on the trolley. This was found to be unsuitable.

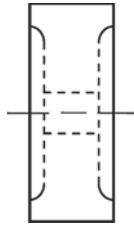

**Figure 11**

- a. Explain what is likely to happen if a plain nut and a plain washer are used to hold the wheels on the trolley.

---

---

1 mark

- b. List **two** alternative fasteners that would be suitable to hold the wheels on the trolley.

---

---

2 marks