

SUPERVISOR TO ATTACH PROCESSING LABEL HERE

STUDENT NUMBER

Letter

Figures
Words

--

VICTORIAN CURRICULUM AND ASSESSMENT AUTHORITY



**Victorian Certificate of Education
2001**

VISUAL COMMUNICATION AND DESIGN

Written examination

Friday 16 November 2001

Reading time: 11.45 am to 12.00 noon (15 minutes)

Writing time: 12.00 noon to 1.30 pm (1 hour 30 minutes)

QUESTION AND ANSWER BOOK

Structure of book

<i>Section</i>	<i>Number of questions</i>	<i>Number of questions to be answered</i>	<i>Number of marks</i>
A	4	4	70
B	2	1	30
			Total 100

Materials

- Question and answer book of 19 pages with a detachable insert of reference material in the centrefold.
- You may use lead and coloured pencils, water-based pens and markers, rulers, set squares, protractors and compasses.
- Tee squares and boards, compressed gas sprays, and equipment requiring a power source are **not** permitted.

Instructions

- Detach the insert from the centre of this book during reading time.
- Write your **student number** in the space provided on the front cover of this book.
- All responses, including all development work, should be included in the spaces provided in this book.
- All written responses must be in English.

This page is blank

SECTION A

Instructions for Section A

You should answer **all** questions in this section.

Question 1



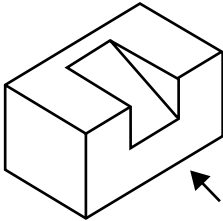
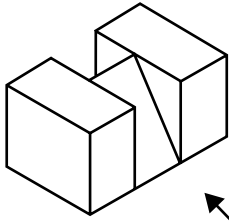
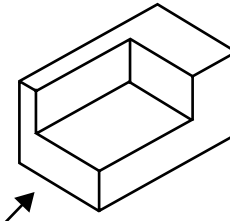
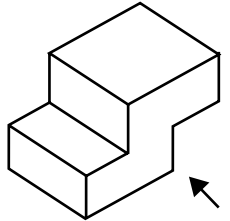

You have been given four pictorial views of different blocks, together with eight 3rd angle orthogonal views. Match the correct orthogonal view with the pictorial view. Write the letter of the matching orthogonal view in the space provided below.

Arrow denotes front view.

Pictorial views

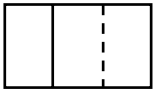
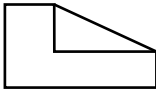
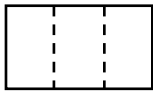
<p>Match the front view</p> <p>1.</p> 	<p>Match the left-hand side view</p> <p>2.</p> 	<p>Match the right-hand side view</p> <p>3.</p> 	<p>Match the top view</p> <p>4.</p> 
--	---	---	--

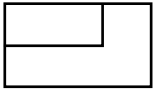
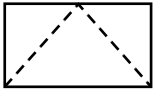
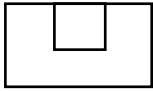
Orthogonal views

<p>a.</p> 	<p>b.</p> 	<p>c.</p> 	<p>d.</p> 
<p>e.</p> 	<p>f.</p> 	<p>g.</p> 	<p>h.</p> 

Pictorial view	1.	2.	3.	4.
Matching orthogonal view				

4 marks

Question 2

- a. In the space below, rotate the object in Figure 1 and draw it as an isometric drawing, from the direction of arrow X, maintaining correct proportions.
- b. Render the object from the direction of the light source.

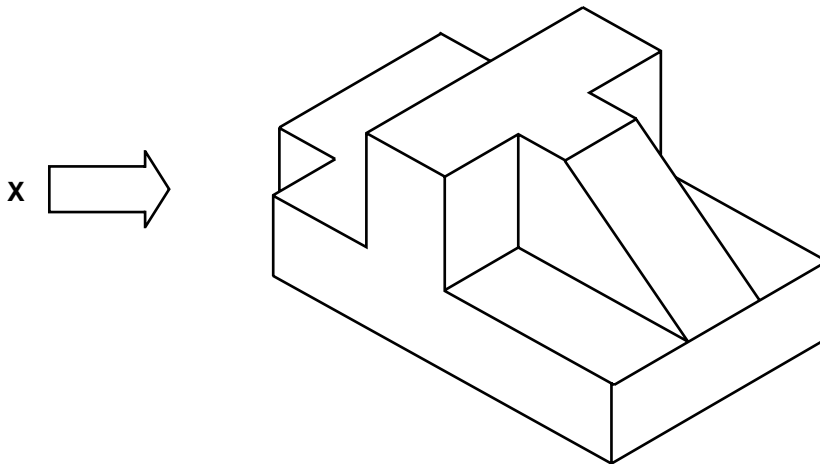
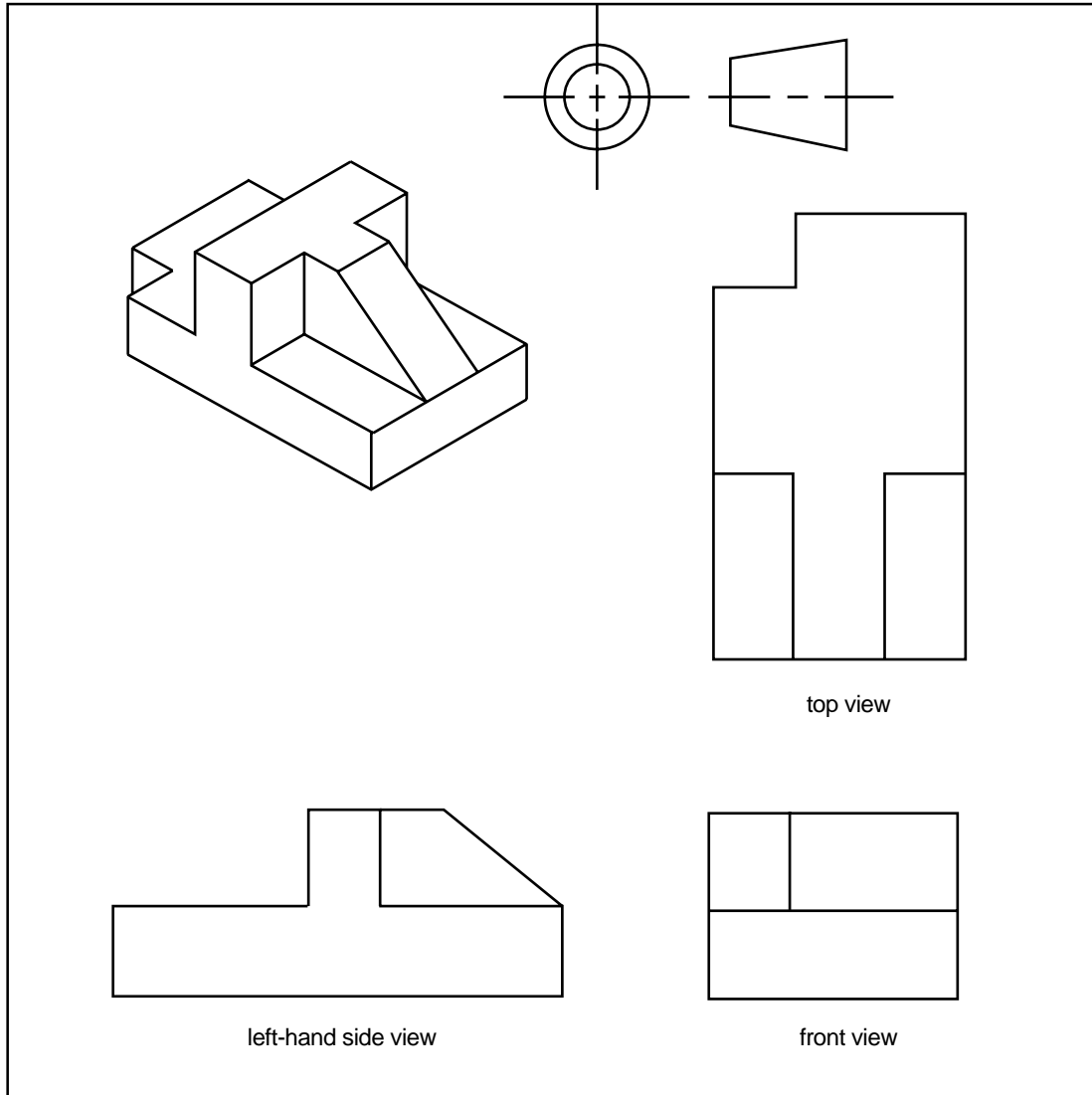

Figure 1

Draw the object in the space below.

10 + 5 = 15 marks

- c. Complete the five missing details in this 3rd angle orthogonal drawing.



$5 \times 2 = 10$ marks

Question 3

Select **one** of the examples of visual communication shown in the detachable insert in the centre of this book and answer the questions below. Write the letter that identifies the example in the box below.

Letter of example

- a. Explain an intended purpose of this visual communication. Refer to the imagery and/or words in the visual communication in your response.

3 marks

- b. Name two design elements that have been applied in the design of this visual communication and evaluate their effectiveness in conveying information and/or ideas in the visual communication.

Design element 1 _____

Design element 2 _____

1 + 3 + 1 + 3 = 8 marks

- c. Name two design principles that have been applied in the design of this visual communication and evaluate their effectiveness in conveying information and/or ideas in the visual communication.

Design principle 1 _____

Design principle 2 _____

1 + 3 + 1 + 3 = 8 marks

Question 4

Answer the questions below with reference to the professional practitioner(s) you studied this year.

- a. Describe two resources used by the professional practitioner(s) in their production of a visual communication(s).

Resource 1 _____

Resource 2 _____

2 + 2 = 4 marks

- b. Discuss two design decisions made by the professional practitioner(s) when choosing materials, production systems, media, design elements and/or principles in their production of a visual communication(s). In your response explain the reason(s) for each decision.

Design decision 1 _____

Design decision 2 _____

6 + 6 = 12 marks

- c. Describe how two professional practitioners worked together in the production of a visual communication(s). In your response name the role of each practitioner.

6 marks

CONTINUED OVER PAGE

**END OF SECTION A
TURN OVER**

SECTION B**Instructions for Section B**

You should answer only **one** question from this section (either Question 1 **or** Question 2).

EITHER**Question 1**

a. 'Mother Earth' produces two different types of biscuit mixture.

- tomato and basil
- honey and banana

You are to design a final presentation for the front surface for a packet for **one** of these biscuit mixtures. Use the biscuit packet shape on page 11 to complete your final presentation.

The information on your packet must include

- the brand name of the biscuit (Mother Earth)
- the type of biscuit mixture (tomato and basil **or** honey and banana)
- images appropriate to the type of biscuit mixture
- colour.

The final presentation on page 11 must be completed vertically.

The reference material in the detachable insert can be used for this question.

Rough working space for development work for Question 1a.

(Note: this work will not be assessed.)

Complete your final presentation for Question 1a. in the biscuit packet shape below.

top of packet



front of packet

MOTHER EARTH BISCUIT MIXTURE PACKET

12 marks

- b. Figure 2 below is a two-dimensional drawing of an unfolded packet. Using the isometric drawing system, draw on page 13 a correctly proportioned, three-dimensional view of the folded packet.

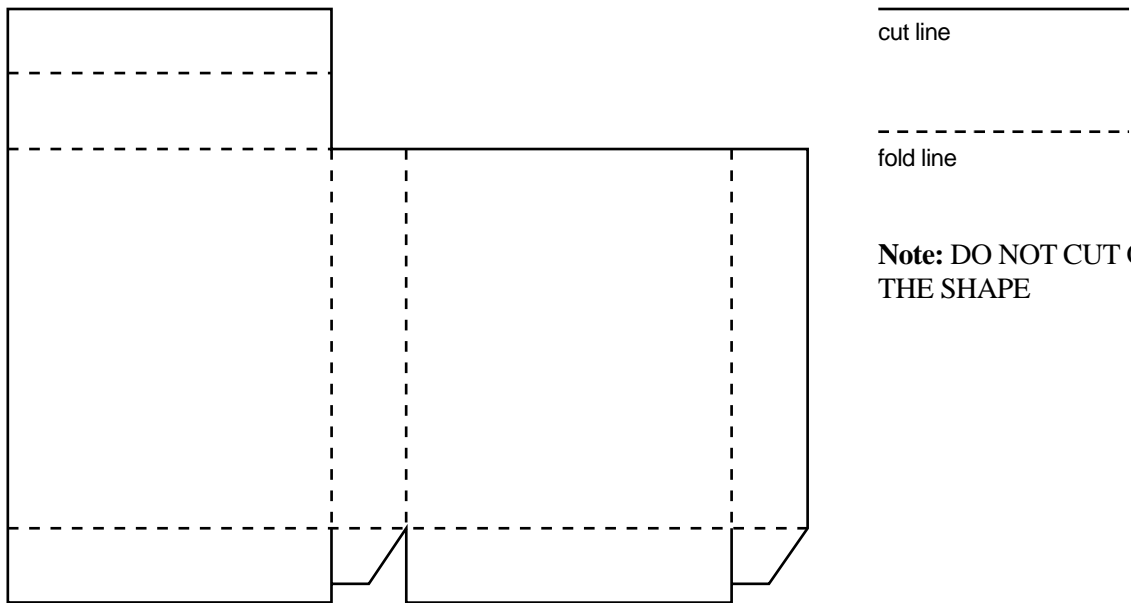
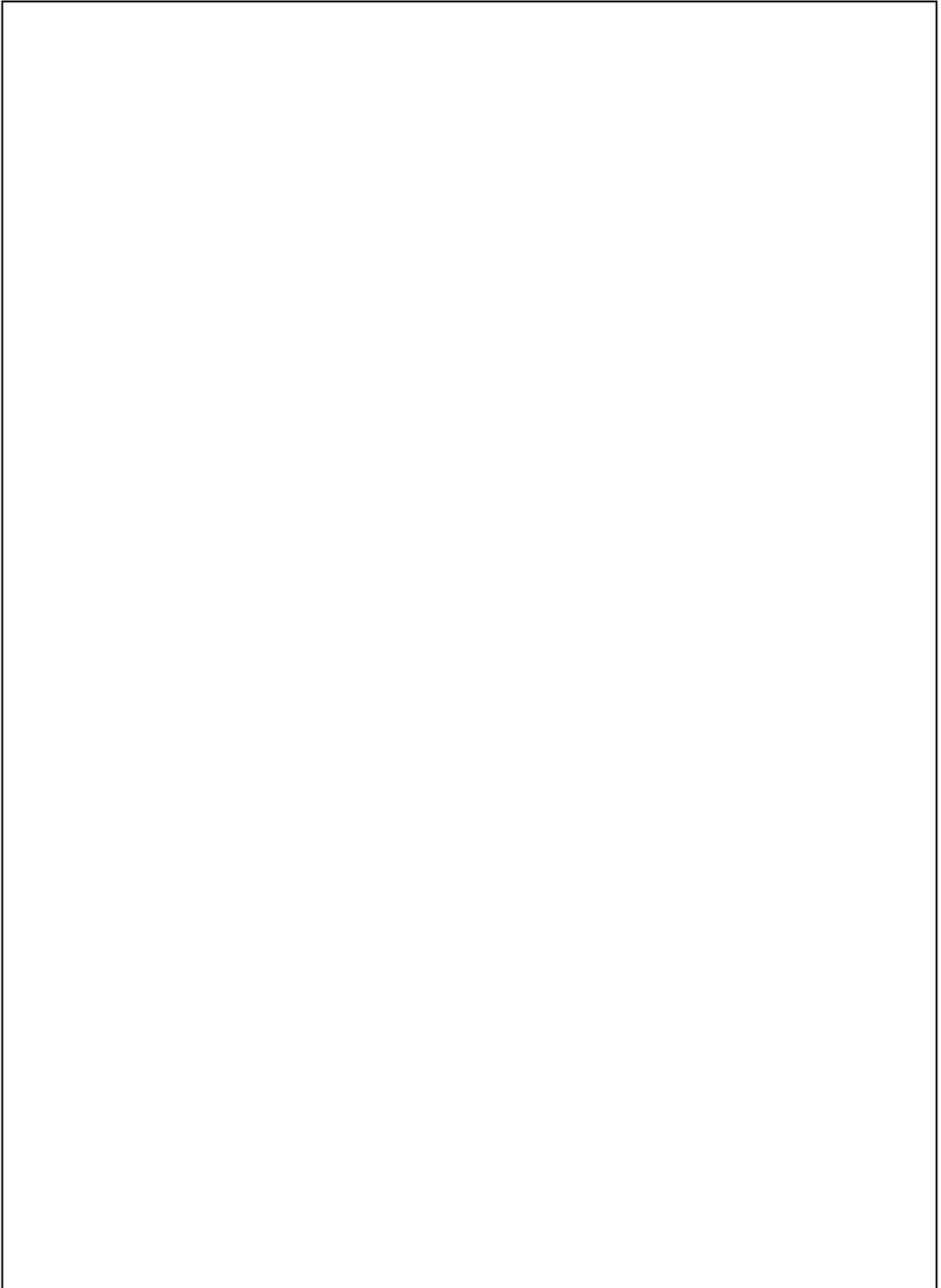

Figure 2

Complete your drawing of the three-dimensional view of the packet in the space below.



6 marks

SECTION B – Question 1 – continued
TURN OVER

- c. The following sequence outlines how Mother Earth biscuits are made.

Preheat oven to 180°C. Grease and flour a biscuit tray. Place biscuit mixture, 1 egg, 1 tablespoon butter and 1/2 cup water into a mixing bowl. Mix with a wooden spoon until all ingredients are combined. Use a spoon to place biscuit-sized amounts on a biscuit tray. Bake for 10 minutes. Allow to cool slightly on tray before transferring to a wire rack to cool.

This sequence is to appear on the back of the Mother Earth biscuit mixture packets as instructions on how to make Mother Earth biscuits.

Produce a diagram that illustrates the sequence of how the biscuits are made.

- The diagram must be **no more than 6 steps (number each step on your final presentation on page 15)**.
- You must use colour in the diagram to emphasise important steps or stages.
- You may use words to clarify the process.
- You may work vertically or horizontally.

Rough working space for development work for Question 1c.

(Note: this work will not be assessed.)

Complete your final presentation for Question 1c. in the space below.

12 marks

SECTION B – continued
TURN OVER

OR

Question 2

a. In Figure 3 below, you have been given a top and a front view of an information booth designed for a national park. The diagram includes the materials used in its construction, the horizon line and the spectator point.

You are to produce a well-proportioned, two-point perspective drawing of the information booth in the space provided on page 17. You must

- use the two-point perspective drawing system
- draw the booth from the spectator point

b. • render the booth using shading and colour

The perspective drawing on page 17 must be completed horizontally.

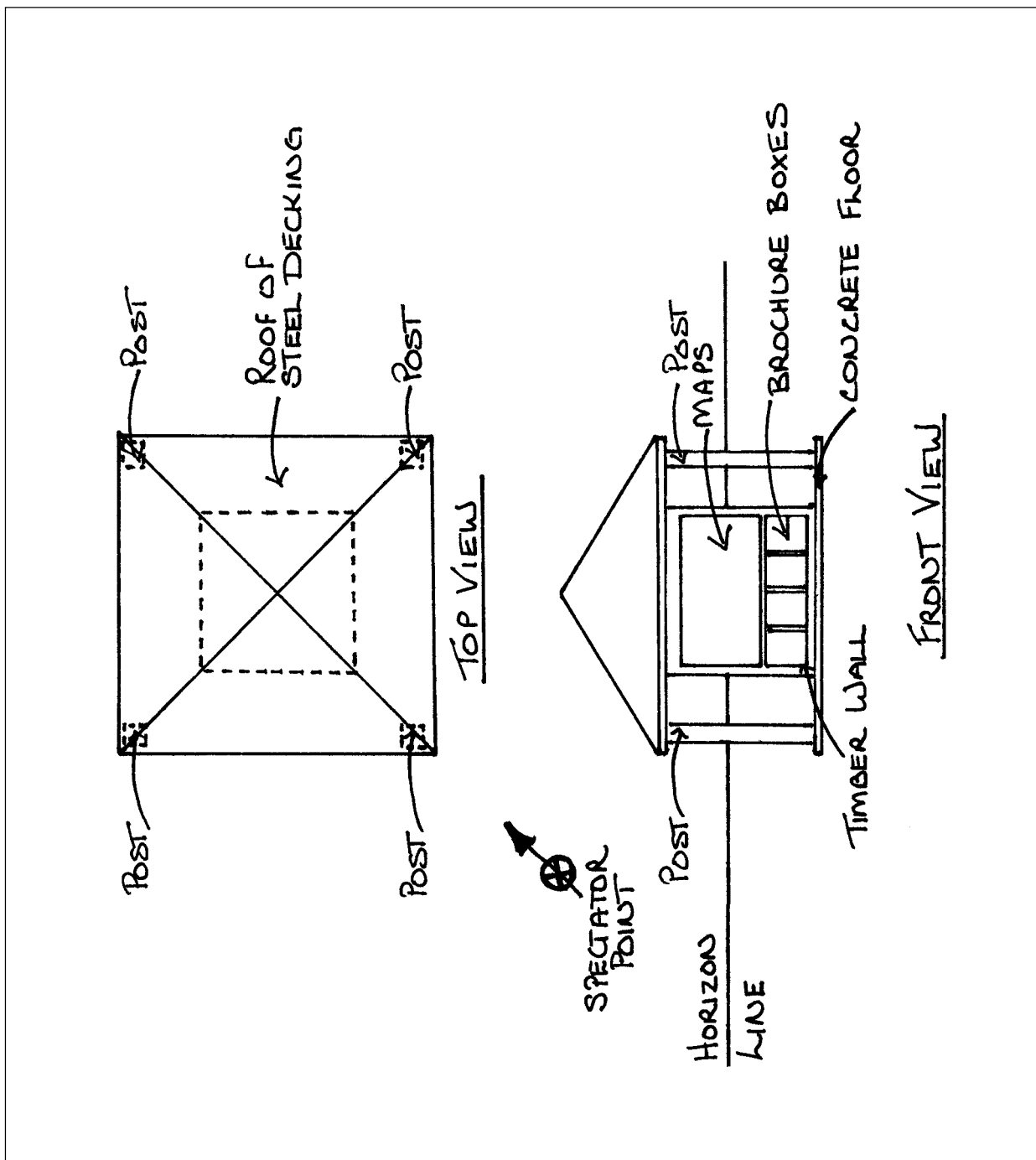

Figure 3

Complete your answer to Question 2a. and 2b. in the **horizontal** space below.

--	--

HORIZON
LINE

12 + 6 = 18 marks

SECTION B – Question 2 – continued
TURN OVER

- c. Using the rectangle provided on page 19, you are to produce a final presentation for the front cover of a brochure to promote Wilsons Promontory National Park.

The brochure is to promote

EITHER

- plants and animals in the national park.

OR

- bushwalking and outdoor activities in the national park.

The information on your brochure must include

- the name of the area – Wilsons Promontory National Park
- the information the brochure is promoting – bushwalking/outdoor activities **or** plants and animals in the area
- images appropriate for the brochure
- colour.

The reference material in the detachable insert can be used for this question. The information may be presented vertically or horizontally.

Rough working space for development work for Question 2c.

(Note: this work will not be assessed.)

Complete your final presentation for Question 2c. in the rectangle below.
You may work vertically or horizontally.

Brochure front cover

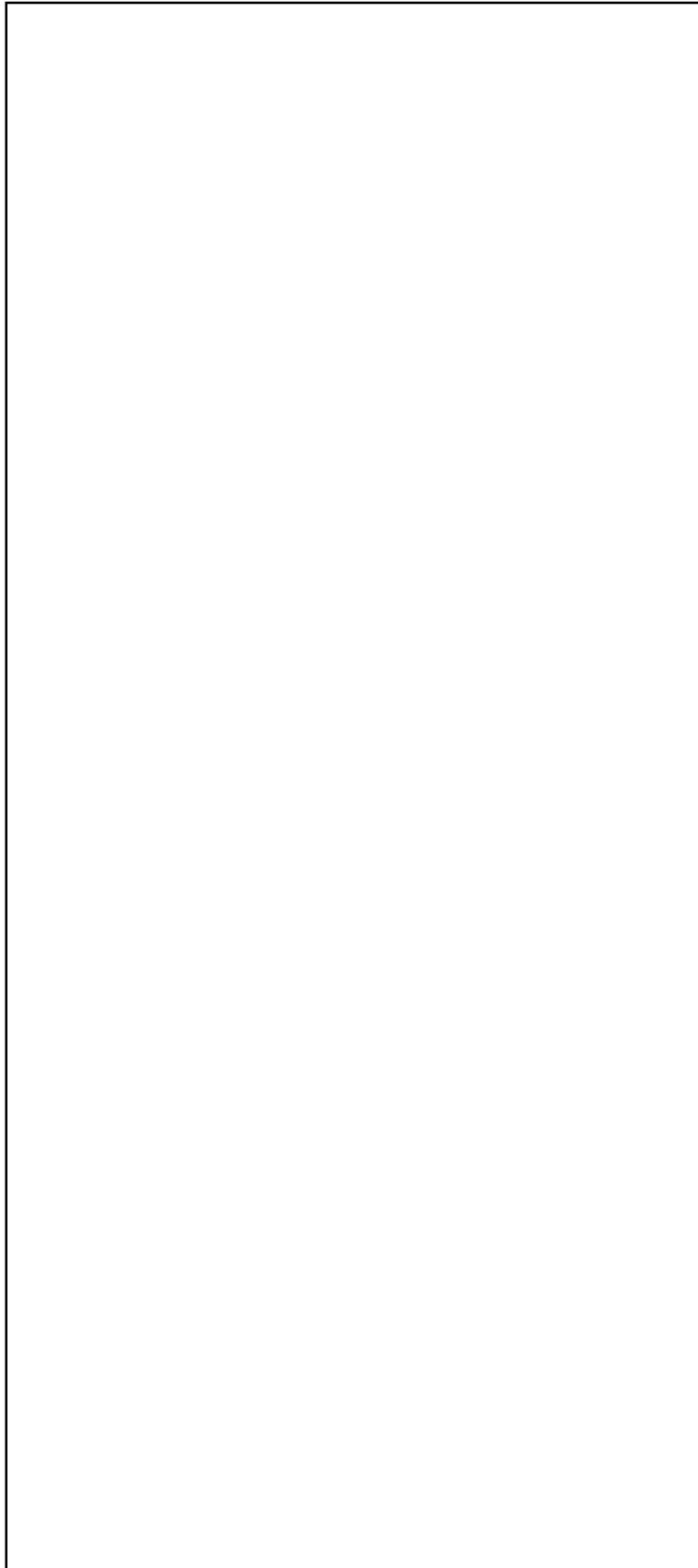

12 marks

Wilson's Promontory National Park
Wilson's Promontory National Park

Wilson's Promontory National Park
Wilson's Promontory National Park



END OF REFERENCE MATERIAL

Please remove from the centre of this book during reading time.

ABCDEFGHIJKLMNOPQRSTUVWXYZ
ABCDEFGHIJKLMNOPQRSTUVWXYZ
ABCDEFGHIJKLMNOPQRSTUVWXYZ
ABCDEFGHIJKLMNOPQRSTUVWXYZ



TURN OVER

REFERENCE MATERIAL FOR SECTION A QUESTION 3

EXAMPLE A



EXAMPLE B

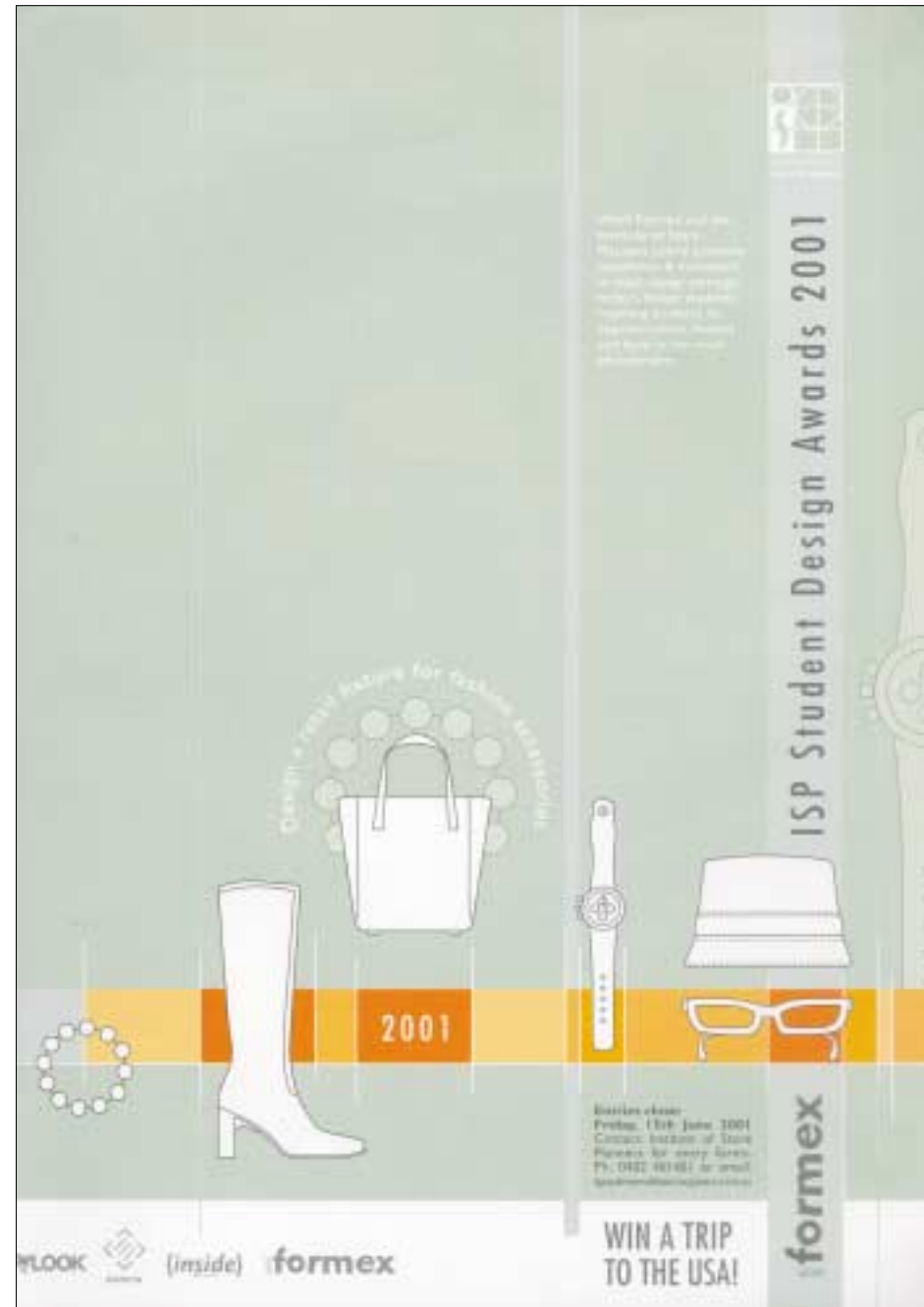

EXAMPLE C

