

General Achievement Test

Section A – Question Book

Tuesday 17 June 2025

- Reading time is **15 minutes**: 9.00am to 9.15am
- Writing time is **2 hours**: 9.15am to 11.15am

Approved materials

- An English and/or bilingual dictionary and one scientific calculator

Materials supplied

- Question Book of 60 pages
- Answer Book including a Multiple-Choice Answer Page

Instructions

- Follow the instructions on the front page of your Answer Book.

Students are **not** permitted to bring mobile phones and/or any other unauthorised electronic devices into the examination room.

Contents	pages
Literacy – Writing Task	
• Part 1 (suggested time 10 minutes) _____	2
• Part 2 (suggested time 20 minutes) _____	3
Multiple-Choice Questions	
• Numeracy (50 questions, suggested time 45 minutes) _____	4–29
• Literacy – Reading (50 questions, suggested time 45 minutes) _____	30–57

Literacy – Writing Task

- There are two parts to this task. Complete each part in the space provided in your Answer Book.
- It is recommended that you spend up to 10 minutes completing Part 1 and up to 20 minutes completing Part 2.
- Your writing will be judged on how effectively you organise your ideas and express yourself.

Part 1

A community centre, managed and run by a small team of volunteers, has just opened. To encourage residents to visit, the following notice was posted on the Community Centre website.

Welcome to the new Community Centre

Open Morning

Saturday 13 September 10 am – 11.30 am

You are warmly invited to attend an Open Morning at the new Community Centre! Come and enjoy refreshments and a chat in our exciting new space. Our friendly team of volunteers will be here to welcome you.

The aim of our Community Centre is to build a strong community by:

- welcoming and engaging with our diverse community
- supporting the development of informal networks in the community.

At the Open Morning, we will share some of our proposals for the activities that will be available at the Community Centre. We are keen to hear **your thoughts** about the extent to which these activities will help us achieve our aim. The activities include:

table tennis
clubs

jewellery-making
workshops

carer and pre-schooler
play sessions

performing arts
classes for teenagers

quiz afternoons
for seniors

We look forward to seeing you on Saturday 13 September!

The Community Team

Task

You attended the Open Morning at the Community Centre. Write an email to the Community Team explaining your opinion on whether **one or more** of the proposed activities will help meet the aim of the Community Centre.

Part 2

Following the opening of the new Community Centre, the Community Team is looking for more volunteers to expand the scope of activities provided by the centre.

The following extract from the Community Centre website provides encouragement to local people to volunteer.

Why become a volunteer?

There are many reasons why people find volunteering rewarding. Just a few hours a week can have a positive impact on you and on others. Volunteering provides opportunities to:

- make friends in the community
- interact with a range of age groups
- gain satisfaction from helping others
- support worthwhile causes
- use existing skill sets and develop new ones.

The following information was posted on the Community Centre website.

Volunteering opportunities at the Community Centre

Interested in joining our team of volunteers? One of these roles may be perfect for you.
Training provided!

looking after the
vegetable patch



helping run activities (craft workshops,
dance sessions, mural painting)



assisting at the
International Cooking Club

dog-walking
for community members

visiting seniors
(as part of the
Good Neighbour Group)

If you would like to join our Community Team as a volunteer,
CLICK HERE to express your interest.

Task

As a local resident, respond to the Community Team on their website outlining why you would like to become a volunteer. Describe the qualities and/or experience you would bring to **one or more** of the volunteering opportunities listed above.

Multiple-Choice Questions – Numeracy

- It is recommended that you spend up to 45 minutes on this task.
 - Answer **all** questions in pencil on the Multiple-Choice Answer Page (page 7) of the Answer Book.
 - Choose the response that is **correct** or that **best answers** the question.
 - A correct answer scores 1; an incorrect answer scores 0.
 - Marks will **not** be deducted for incorrect answers.
 - No marks will be given if more than one answer is completed for any question.
-

Questions 1 and 2

Subscribers to a video streaming company choose between the Standard plan and the Premium plan.

Subscribers can choose to pay monthly or annually.

This table shows the different prices of the plans when paying monthly or annually.

Payment frequency	Standard plan price	Premium plan price
monthly	\$13.99	\$17.99
annually	\$139.99	\$179.99

1 Levi chooses the Standard plan.

How much extra would Levi spend each year if he paid monthly rather than annually?

- A. \$27.89
- B. \$31.98
- C. \$40.00
- D. \$126.00

2 New subscribers get a 15% discount for their first year.

A new subscriber chooses the Premium plan paying annually.

What is the cost of the plan for the first year?

- A. \$26.99
- B. \$152.99
- C. \$164.99
- D. \$206.99

Questions 3 and 4

Children aged 9–11 years and 12–14 years were surveyed to identify the creative activities they participate in.

This graph shows the results of the survey.

Children’s participation rates in different creative activities

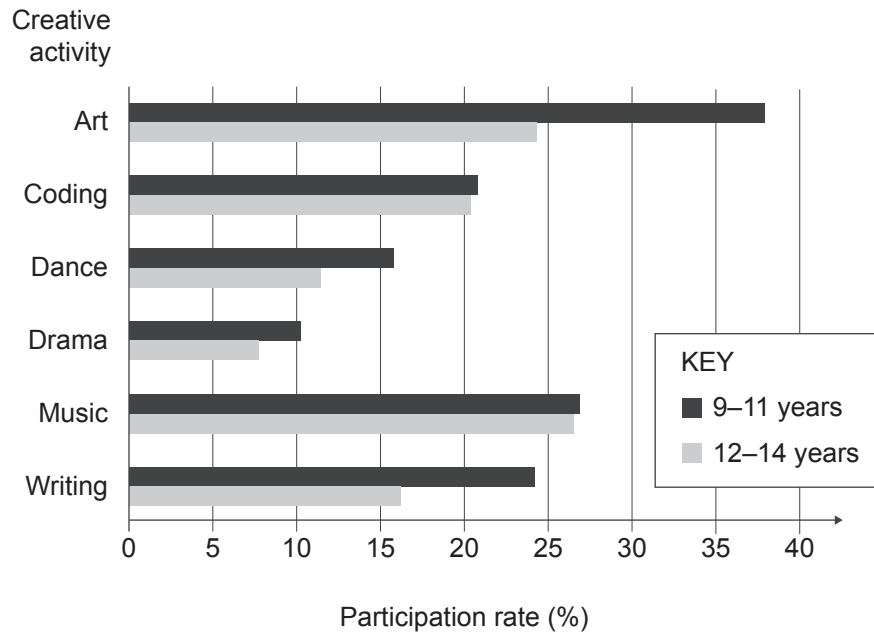

- 3** For children aged 9–11 years, which activity’s participation rate is closest to **twice** that of drama?
- A. Coding
 - B. Writing
 - C. Music
 - D. Art
- 4** A 12-year-old child is selected randomly and asked which creative activities they participate in. What is the **most** likely answer?
- A. Art
 - B. Coding
 - C. Dance
 - D. Music

7 This map shows a line connecting the two sites where the water samples were taken.

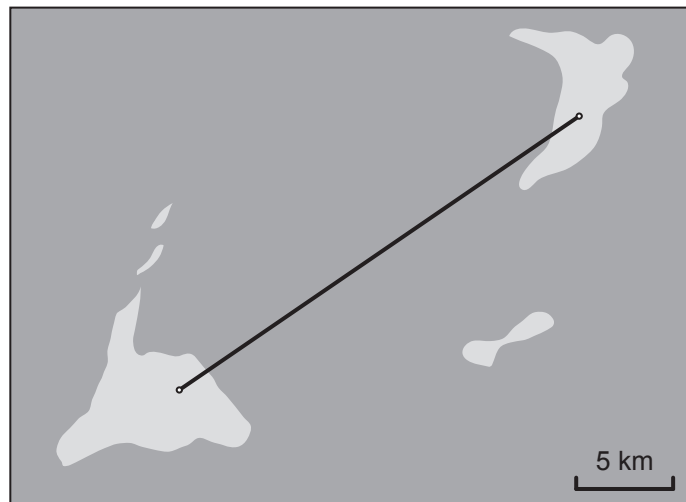

Which is closest to the distance between the two sites?

- A. 5 km
- B. 15 km
- C. 25 km
- D. 35 km

Questions 8–10

At a refill shop, customers bring their own containers and pay according to the mass of the food they buy.

The price of muesli is \$2.38 per 100 g at the refill shop.

8 What is the cost of 550 g of muesli?

- A. \$7.88
- B. \$13.09
- C. \$14.28
- D. \$16.50

9 One customer eats a 40 g portion of muesli every day.

Before going to the shop, the customer had 350 g of muesli in their pantry.

The customer buys 500 g of muesli from the shop.

How many **full** portions of muesli does the customer have in total immediately after buying the muesli?

- A. 20
- B. 21
- C. 22
- D. 23

10 The shop offers a bulk-buy discount.

The discounted price of muesli is \$1.98 per 100 g if customers buy 5 kg or more.

How much does the discount save a customer who buys 5.5 kg of muesli?

- A. \$0.99
- B. \$8.38
- C. \$11.00
- D. \$22.00

Questions 11 and 12

This table shows salaries that apply to staff working at a theatre.

Pay grade	Full-time monthly salary
A	\$4 440
B	\$5 200

- 11** The theatre employs 4 full-time and 3 part-time staff at pay grade A, and a further 3 full-time staff at pay grade B.

The part-time staff work half as many hours as the full-time staff and are paid half the full-time salary.

What is the total monthly cost of the theatre staff salaries?

- A. \$31 140
 - B. \$33 360
 - C. \$40 020
 - D. \$40 970
- 12** The full-time monthly salaries for both pay grades are increased by the same amount of money. This means pay grade A goes up by 4.8%.
- Which is closest to the percentage increase in the full-time monthly salary for pay grade B?
- A. 4.1%
 - B. 4.3%
 - C. 4.6%
 - D. 4.8%

Questions 13–15

In a word game, letter tiles are used to form words.

- 13** The letter tiles are all squares with side lengths of 2.1 cm.

Which is closest to the total area of the tiles used in a 3-letter word?

- A. 6.3 cm^2
- B. 13.2 cm^2
- C. 25.2 cm^2
- D. 39.7 cm^2

- 14** There are 81 letter tiles in a bag, of which 45 are consonants and the rest are vowels.

A player picks two tiles from the bag at random.

The first tile is a vowel.

What is the probability that the second tile is also a vowel?

- A. $\frac{35}{80}$
- B. $\frac{35}{81}$
- C. $\frac{36}{80}$
- D. $\frac{36}{81}$

15 Each letter tile has a number that represents its points value.

- Tiles without a dashed border are called normal tiles and are worth the number of points shown on the tile.
- Tiles with a dashed border are called special tiles and are worth triple the number of points shown on the tile.

The following method is used to calculate the total points scored for each word.

- Triple the points of each special tile played.
- Add together the points scored for both the normal tiles and special tiles.
- If the word has five letters, double the score.

This word is played:

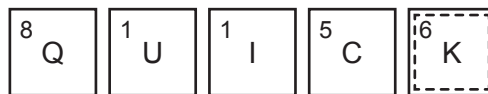

Which calculation represents the total points scored for the word?

- A. $2 \times (8 + 1 + 1 + 5 + 6 \times 3)$
- B. $2 \times (8 + 1 + 1 + 5 + 6) \times 3$
- C. $(2 \times 8 + 1 + 1 + 5 + 6) \times 3$
- D. $2 \times 8 + 1 + 1 + 5 + 6 \times 3$

Questions 16 and 17

The field of view of an animal is made up of:

- the binocular field, which is the region visible to both eyes
- the monocular fields, which are the regions visible to one eye only.

The area behind the animal that is outside its field of view is called the blind area.

This image shows the field of view of a cat, looking down towards the cat from above.

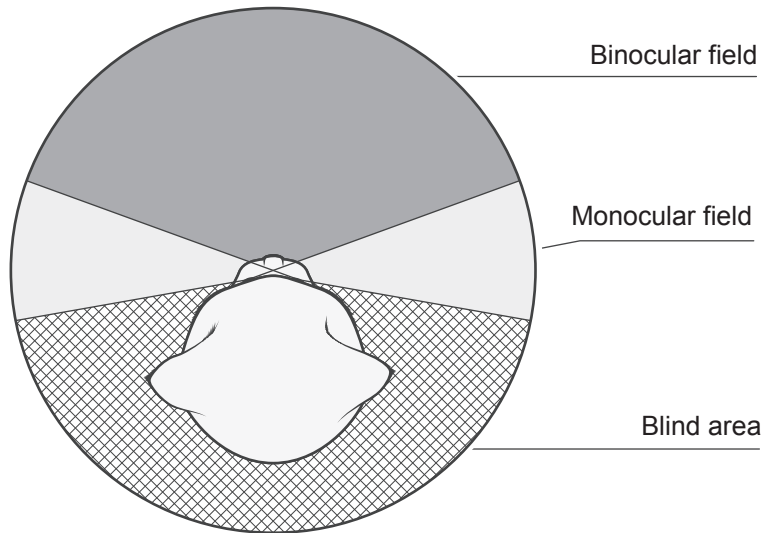

16 Which is closest to the angle of the cat's total field of view?

- A.** 100°
- B.** 140°
- C.** 170°
- D.** 200°

17 A dog's binocular field covers 60° and its two monocular fields each cover 90° .
What is the angle of the dog's blind area?

- A.** 60°
- B.** 120°
- C.** 150°
- D.** 210°

Questions 18–20

The sun protection factor (SPF) of a sunscreen shows how effective it is at blocking the harmful ultraviolet B (UVB) radiation in sunlight.

SPF is defined as the number of units of UVB radiation that the sunscreen must be exposed to for 1 unit to pass through.

For example, SPF 30 means that $\frac{1}{30}$ of UVB radiation is **not** blocked by the sunscreen.

18 What percentage of UVB radiation is **not** blocked by SPF 50 sunscreen?

- A. 2%
- B. 10%
- C. 25%
- D. 50%

19 One particular sunscreen is tested.

It is found that when the sunscreen is exposed to 5000 units of UVB radiation, 250 units of UVB radiation pass through.

What is the SPF of this sunscreen?

- A. 5
- B. 20
- C. 25
- D. 50

20 The protection offered by sunscreen wears off over time.

Regardless of the SPF, to protect their whole body an adult should apply at least 35 mL of sunscreen every 2 hours.

How many 200 mL bottles of sunscreen will 1 adult need to protect their whole body for 6 days if they are in the sun between 11 am and 5 pm each day?

- A. 2
- B. 3
- C. 4
- D. 6

Questions 21 and 22

A company sells different types of luggage.

The company sells its products both online and instore.

This pie chart shows the proportion of the company's customers who have bought a product online only, instore only or both online and instore.

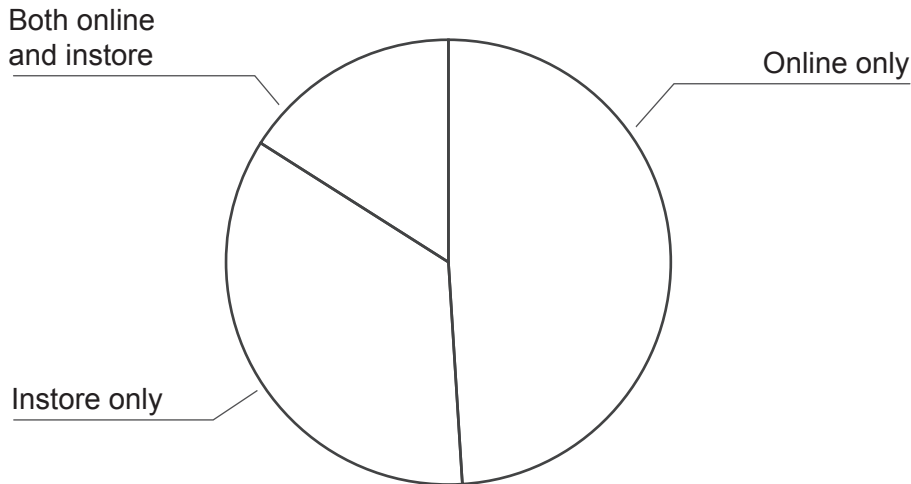

- 21 Which is closest to the percentage of the company's customers who have bought a product online?
- A. 35%
 - B. 49%
 - C. 65%
 - D. 84%
- 22 The proportions are recalculated and the pie chart is updated every time someone buys something from the company.
- Which change to the pie chart could **not** happen when a customer buys a bag instore?
- A. The 'Online only' region increases in area.
 - B. The 'Online only' region decreases in area.
 - C. The 'Both online and instore' region increases in area.
 - D. The 'Both online and instore' region decreases in area.

Questions 23–25

The Indian Pacific route between Sydney and Perth is the longest train journey in Australia, with a total length of 4 352 km.

- 23** The Indian Pacific train was scheduled to arrive in Perth at 1.50 pm on Saturday. A delay results in the train arriving in Perth at 2.35 am on Sunday. How long was the train delayed?
- A.** 1 h 25 min
 - B.** 12 h 45 min
 - C.** 14 h 25 min
 - D.** 24 h 45 min
- 24** When the Indian Pacific train is moving, it travels at an average speed of 85 km/h. A particular journey from Sydney to Perth included 20 hours spent stopped at stations. Which is closest to the time the journey took?
- A.** 31 h
 - B.** 41 h
 - C.** 61 h
 - D.** 71 h
- 25** The route includes the world's longest stretch of straight railway track, a 478 km section of track that runs across the Nullarbor Plain. At its top speed, the train could travel the straight section across the Nullarbor Plain in 4 hours and 9 minutes. Which is closest to the train's top speed?
- A.** 98 km/h
 - B.** 115 km/h
 - C.** 117 km/h
 - D.** 120 km/h

Questions 26–28

The following exclusion zone rules apply to whale-watching boats.

1. Stay at least 100 m away from a whale.
2. Stay out of the 60° angles directly in front of and behind the whale when between 100 m and 300 m away from the whale.

This diagram shows the exclusion zone around a whale that applies to whale-watching boats.

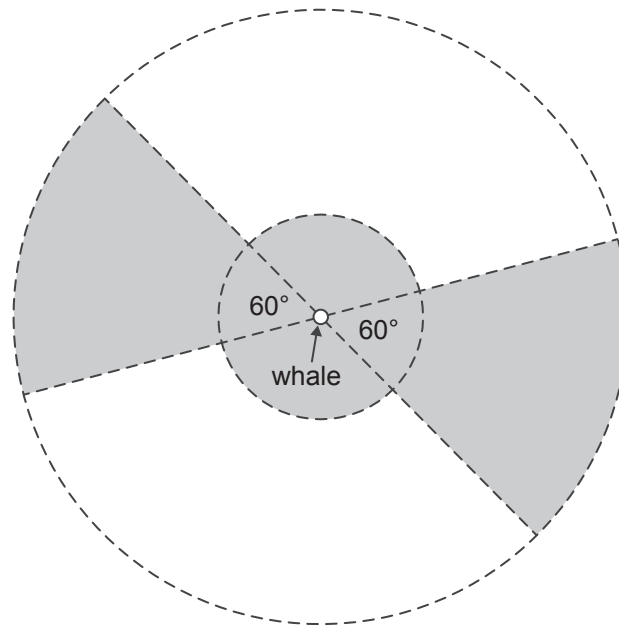

KEY

 exclusion zone

- 26** Which is closest to the percentage of the region between 100 m and 300 m from a whale that these boats are allowed in?
- A. 17%
 - B. 33%
 - C. 67%
 - D. 83%

27 This diagram shows the exclusion zones around two whales.

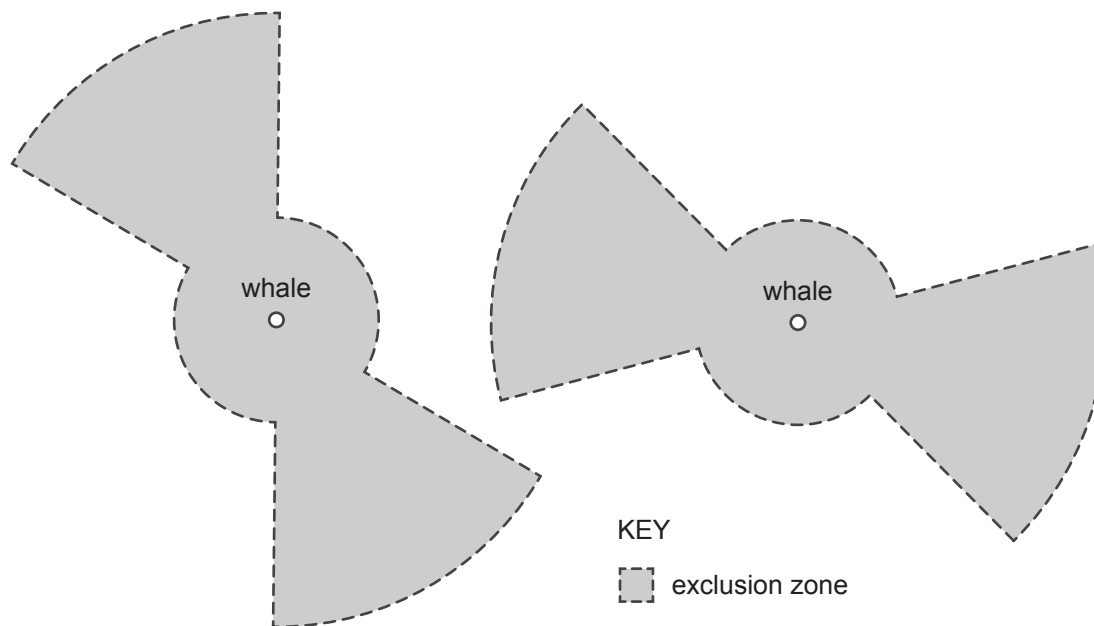

Approximately how far apart are the two whales?

- A. 250 m
- B. 400 m
- C. 500 m
- D. 650 m

28 Passengers from several boating tours reported the different animals they saw. This diagram shows the number of passengers on a tour who saw whales, dolphins or both.

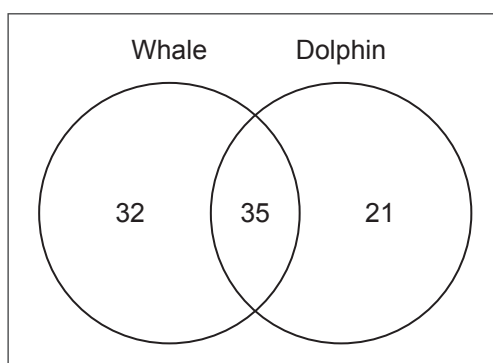

What is the probability that a randomly selected passenger who saw a whale also saw a dolphin?

- A. $\frac{32}{56}$
- B. $\frac{32}{67}$
- C. $\frac{35}{56}$
- D. $\frac{35}{67}$

Questions 29–31

This diagram shows the *rise* and *going* of five steps on a staircase.

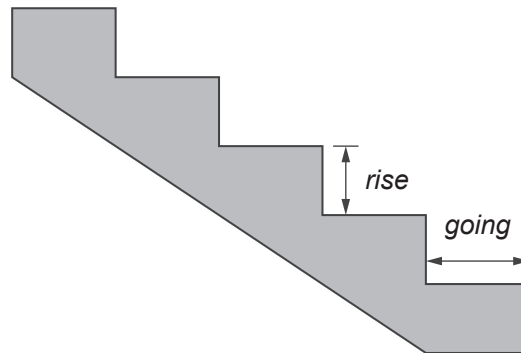

This table shows the minimum and maximum values for the *rise* and *going* that comply with the Australian Standard for staircase design.

	Minimum	Maximum
<i>rise</i> length (mm)	130	225
<i>going</i> length (mm)	215	355

- 29** An American manufacturer makes a staircase with a *rise* of 7 inches and a *going* of 8 inches.
1 inch = 25.4 mm

Consider the following two statements.

Statement 1: The *rise* of the staircase is compliant with the Australian Standard for staircase design.

Statement 2: The *going* of the staircase is compliant with the Australian Standard for staircase design.

Which of the statements are correct?

- A. Statement 1 only
- B. Statement 2 only
- C. both Statement 1 and Statement 2
- D. neither Statement 1 nor Statement 2

- 30** The value of the following expression is used as a measure of staircase safety.

$$2r + g$$

where:

r = *rise* length (mm)

g = *going* length (mm)

The value of the expression must be between 550 mm and 700 mm to comply with the Australian Standard.

What is the maximum *going* length for a staircase with a *rise* length of 190 mm that complies with the Australian Standard?

- A. 190 mm
 - B. 320 mm
 - C. 355 mm
 - D. 380 mm
- 31** Non-slip paint is applied to the *going* of each step of a staircase.
- The staircase is 1.5 metres wide and has 13 steps, each of which has a *going* length of 0.35 metres.
- The cost of paint is \$55 per square metre and the labour cost is \$175 in total.
- To the nearest dollar, how much does it cost to cover the *goings* of the steps with non-slip paint?
- A. \$204
 - B. \$375
 - C. \$425
 - D. \$550

Questions 32–34

A company designs and makes triangular windows.

This image shows an example of the company's triangular windows.

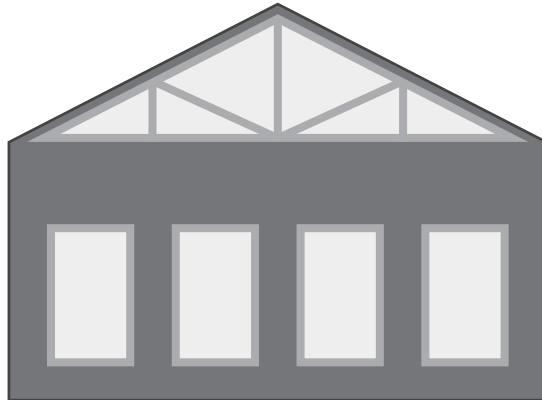

not to scale

32 This diagram shows a window that has been designed to follow a roof slope of 35° .

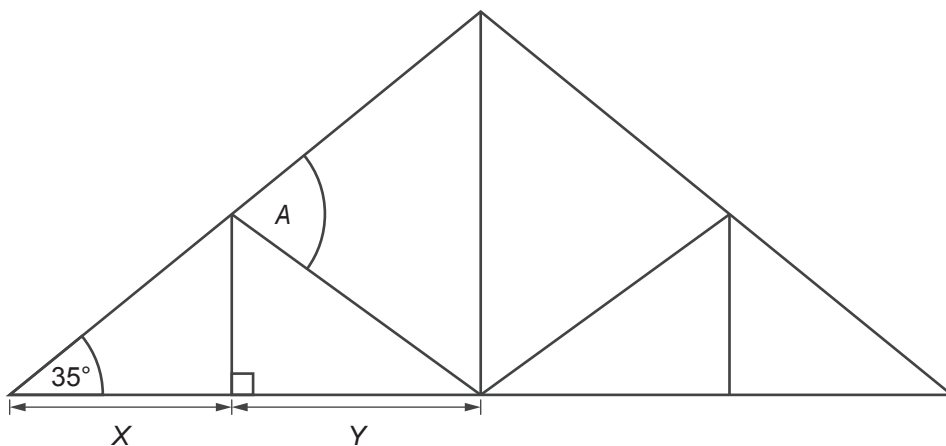

not to scale

If X is equal to Y , what is the value of angle A ?

- A. 55°
- B. 60°
- C. 65°
- D. 70°

33 This diagram shows the dimensions of a different window.

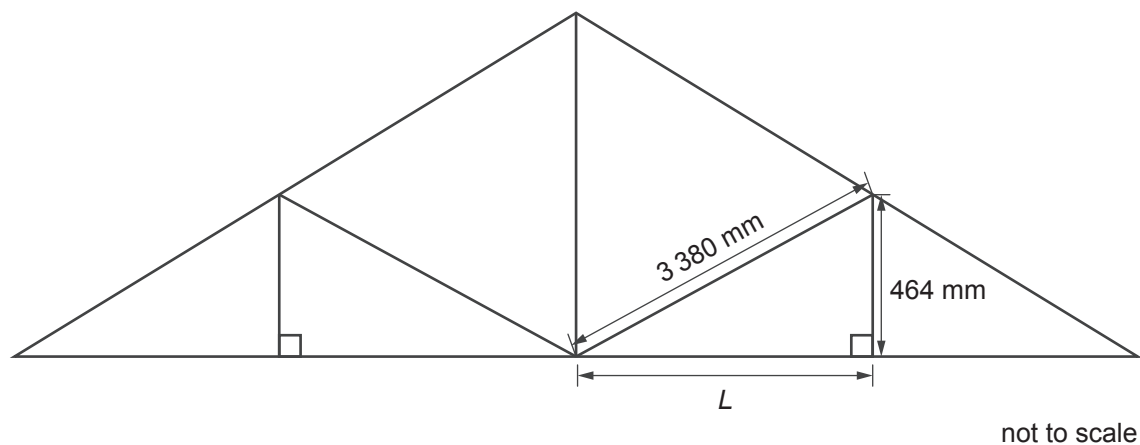

What is the value of length L ?

- A. 2916 mm
- B. 3148 mm
- C. 3348 mm
- D. 3412 mm

34 This diagram shows the dimensions of a building fitted with a different triangular window.

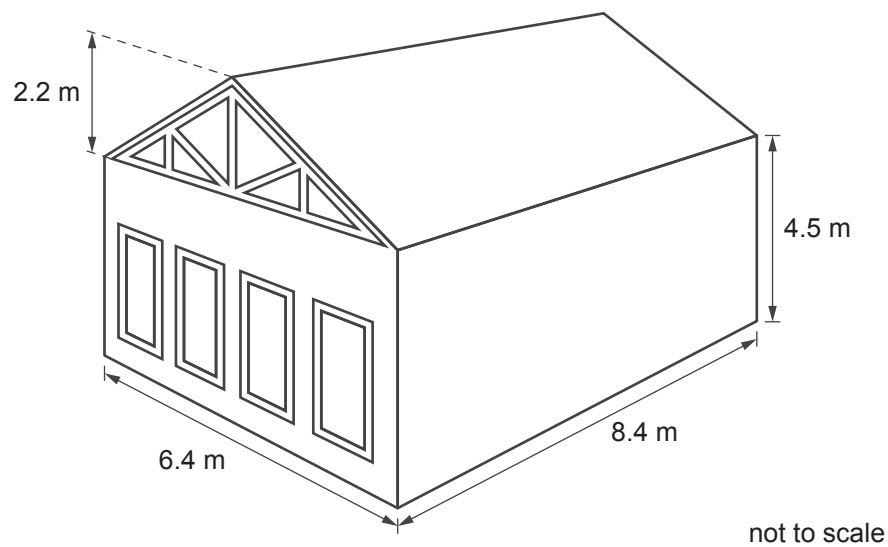

Which is closest to the total volume of the building?

- A. 180 m^3
- B. 242 m^3
- C. 290 m^3
- D. 301 m^3

Questions 35 and 36

A government operates a heat alert system. It uses the system to notify the community when temperatures in a particular district are forecast to be high enough to endanger human health.

A heat alert is issued for a district when the day's average temperature forecast exceeds the district's threshold temperature.

A day's average temperature forecast is defined as:

$$\frac{\left(\begin{array}{l} \text{the day's maximum} \\ \text{forecast temperature} \end{array} \right) + \left(\begin{array}{l} \text{the following day's minimum} \\ \text{forecast temperature} \end{array} \right)}{2}$$

This table shows the threshold temperatures and the number of heat alerts issued over two years for four different districts.

District	Threshold temperature	Number of alerts	
		Year 1	Year 2
Eastern	34 °C	11	4
Central	30 °C	5	2
South West	30 °C	3	1
Northern	32 °C	8	2

35 Which district had the greatest percentage decrease in alerts from Year 1 to Year 2?

- A. Eastern
- B. Central
- C. South West
- D. Northern

36 Monday's maximum forecast temperature is 36 °C for the Eastern district.

What minimum forecast temperature on Tuesday would make Monday's average temperature forecast equal to the threshold temperature for the Eastern district?

- A. 24 °C
- B. 28 °C
- C. 32 °C
- D. 35 °C

Questions 37–39

A gardener digs out earth to make a rectangular trench for a new path. The trench is $340\text{ cm} \times 36\text{ cm}$ and 5 cm deep.

37 What volume of earth does the gardener dig out?

- A. 3760 cm^3
- B. 12240 cm^3
- C. 16000 cm^3
- D. 61200 cm^3

38 A trench liner is a plastic sheet that is placed into a trench to protect its floor and walls.

The gardener places a rectangular trench liner into the trench.

The liner covers the floor and all four walls of the trench.

What are the minimum possible dimensions of the rectangular liner?

- A. $340\text{ cm} \times 46\text{ cm}$
- B. $345\text{ cm} \times 41\text{ cm}$
- C. $350\text{ cm} \times 46\text{ cm}$
- D. $355\text{ cm} \times 41\text{ cm}$

39 The gardener has square paving slabs that have a side length of 36 cm and are 5 cm thick. He decides to break these paving slabs and lay them in the trench in an irregular pattern.

Figure 1 shows one of the paving slabs. Figure 2 shows a small section of broken paving slabs laid in an irregular pattern.

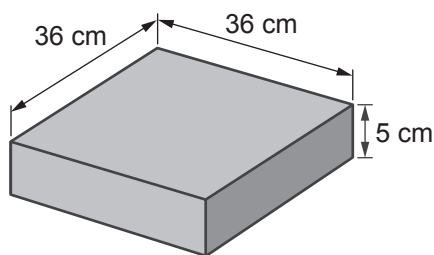

Figure 1

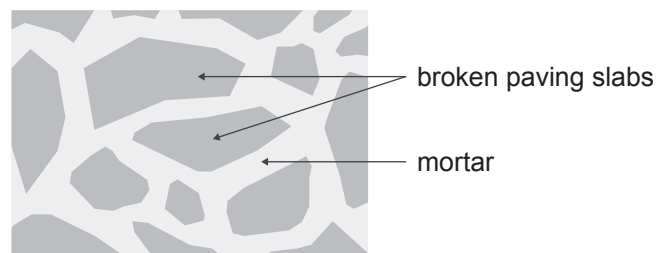

Figure 2

The gardener breaks up 7 whole paving slabs and lays all the pieces in the trench in an irregular pattern.

All the gaps between the paving pieces, and between the paving pieces and the edges of the trench, are filled with mortar.

What is the visible surface area of the mortar?

- A. 3168 cm^2
- B. 9072 cm^2
- C. 10944 cm^2
- D. 21312 cm^2

Questions 40 and 41

The roof of a building has sections that face north, south, east and west.

An engineer considers two options for installing solar panels on the building.

- Option 1 is to cover the entire north-facing section with solar panels.
- Option 2 is to cover the entire east-facing and west-facing sections with solar panels.

There are no trees or buildings casting shade on any section of the roof at any time during the day.

The engineer uses a mathematical model to predict the power output for both options at different times on a sunny day.

This graph shows the prediction.

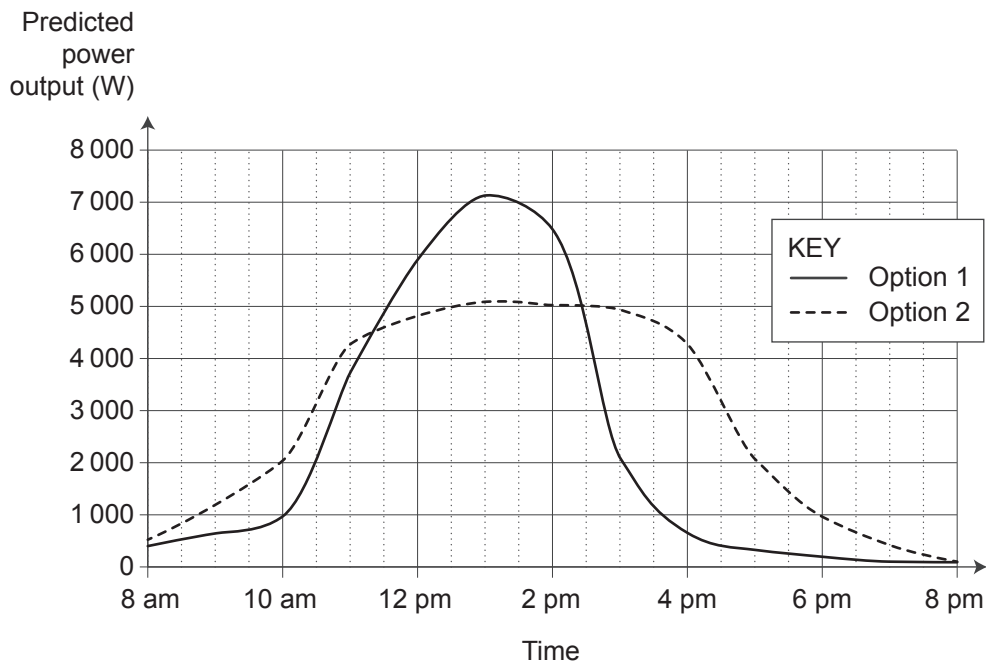

40 During which period is the predicted power output of Option 2 greater than Option 1?

- between 11.20 am and 2.25 pm
- between 11.35 am and 2.55 pm
- before 11.20 am and after 2.25 pm
- before 11.35 am and after 2.55 pm

41 The engineer considers a third option.

Option 3 is to cover a quarter of the north-facing section, half of the east-facing section and half of the west-facing section with solar panels.

What is the predicted power output of Option 3 at 2 pm on a sunny day?

- 4 125 W
- 4 500 W
- 6 625 W
- 11 500 W

Questions 42–44

A reptile park keeps funnel-web spiders. The park's keepers extract venom from the spiders to make anti-venom.

Each spider can undergo an attempted extraction no more than once in a day.

If the attempted extraction is unsuccessful, the keeper tries a different spider.

In total, the keepers make 42 successful extractions of venom each day.

The record for the greatest mass of venom they have extracted at one time from a single spider is 0.35 milligrams.

42 How many grams is 0.35 milligrams?

- A. 0.000 35 g
- B. 0.003 5 g
- C. 35 g
- D. 350 g

43 This diagram shows different likelihoods.

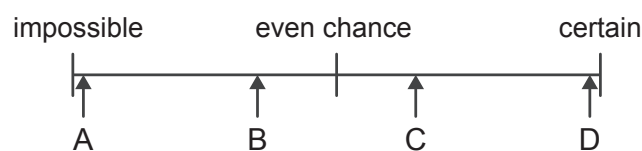

Which arrow **best** represents the likelihood that a total of **less than** 28.5 milligrams of venom is obtained from 42 successful extractions?

- A. A
- B. B
- C. C
- D. D

44 When the record mass of 0.35 milligrams was extracted, it was 19% more than the previous record.

Which is closest to the previous record?

- A. 0.16 milligrams
- B. 0.18 milligrams
- C. 0.28 milligrams
- D. 0.29 milligrams

Questions 45–47

A tailor is making a skirt from a square piece of fabric using the following method:

Step 1: Fold the fabric in half.

Step 2: Fold the fabric in half a second time.

Step 3: Lay the pattern templates onto the folded fabric.

Step 4: Cut around the pattern templates.

This diagram shows how the fabric is folded.

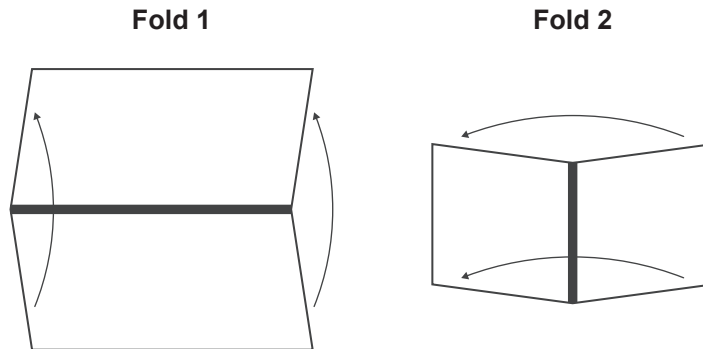

This diagram shows the pattern templates laid onto the twice-folded fabric and the cutting lines.

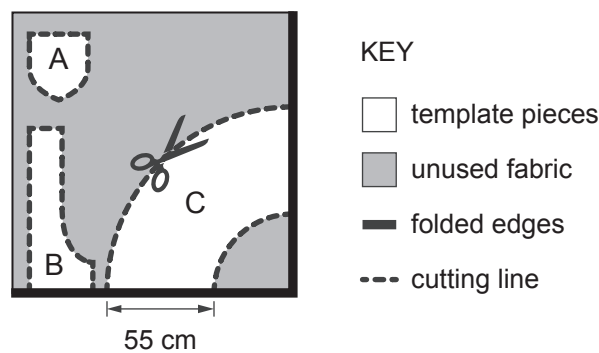

45 The 55 cm measurement shown for template C is 30 mm more than the desired final length of the skirt.

What is the desired final length of the skirt?

- A. 25.00 cm
- B. 52.00 cm
- C. 54.70 cm
- D. 54.97 cm

- 46** The tailor cuts the fabric along the cutting lines of the three pattern templates. No cuts are made along a template edge that is on a fabric fold.

The unused fabric that was not under any of the template pieces is then discarded.

How many whole fabric pieces will the tailor have once the cutting is complete and the unused fabric is discarded?

- A. 6
- B. 7
- C. 10
- D. 12

- 47** What is the unfolded shape of each piece of fabric cut out using pattern template B?

A.

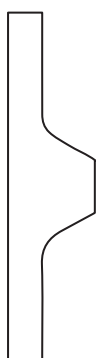

B.



C.

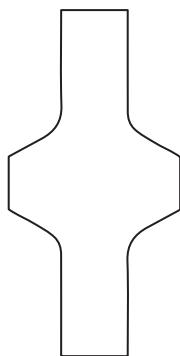

D.

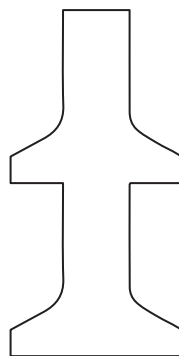

Questions 48–50

Drones are being trialled for use in transporting samples from small rural hospitals to larger hospitals for analysis.

- 48** In one journey, a drone started at Kingaroy and travelled to Nanango and then on to Murgon before returning to Kingaroy.

This map shows the journey.

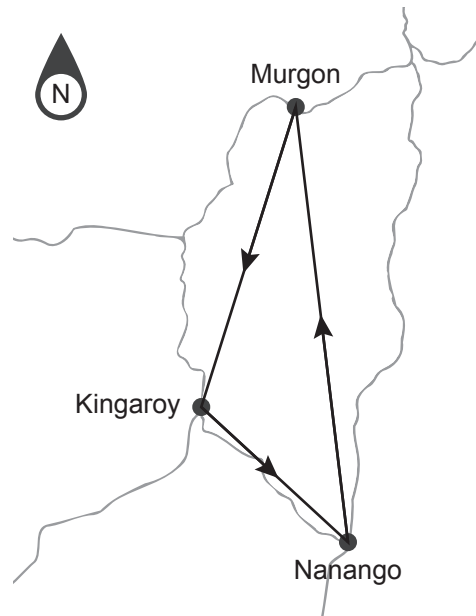

Which sequence of true bearings did the drone follow?

- A. 116°T , 023°T , 041°T
- B. 116°T , 041°T , 023°T
- C. 133°T , 006°T , 163°T
- D. 133°T , 354°T , 197°T

- 49 This map shows the region covered by a particular drone service. The area inside the circle is covered by the drone service.

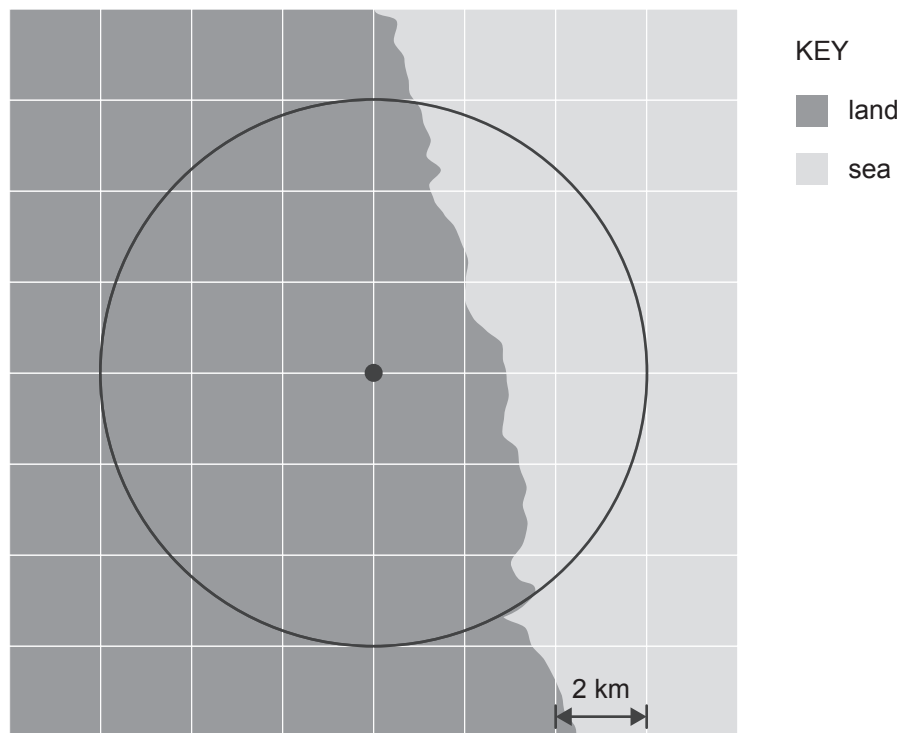

- Which is closest to the area of **land** the drone service can cover?
- A. 20 km²
B. 40 km²
C. 80 km²
D. 120 km²
- 50 The range of a drone depends on the mass of the load it is carrying. The range can be estimated using this formula:
- $$r = 230 - 20p$$
- where:
- r = range (km)
 p = mass of the load (kg)
- For one trip, the drone will carry 8 test samples, each of which has the same mass. The estimated range of the drone is 206 km on this trip. What is the mass of **one** of the test samples?
- A. 0.150 kg
B. 0.500 kg
C. 0.833 kg
D. 2.725 kg

Multiple-Choice Questions – Literacy – Reading

- It is recommended that you spend up to 45 minutes on this task.
- Answer **all** questions in pencil on the Multiple-Choice Answer Page (page 7) of the Answer Book.
- Choose the response that is **correct** or that **best answers** the question.
- A correct answer scores 1; an incorrect answer scores 0.
- Marks will **not** be deducted for incorrect answers.
- No marks will be given if more than one answer is completed for any question.

Questions 51–53

The following email is about an upcoming webinar.

_ □ ×

Dear Joanna,

Thank you for registering your organisation for our **Mindfulness in the Workplace** webinar. This will be presented by Dr Harmonia Aarav, a business psychologist with over a decade of experience supporting organisations to enhance their wellbeing practices. Dr Harmonia Aarav will discuss mindfulness techniques that can be implemented in the workplace. These practices have been associated with enhanced focus, task performance and work satisfaction. There will be opportunities for your employees to ask questions at the end.

You can find information about how to join this webinar below.

Date: Wednesday 16th July
Time: 12:00 pm (AEST)
ID: 87946520138

How to join:

1. Join from PC, Mac, iPad or Android.
Paste the following URL into your browser:
<https://zap/meeting/h/475099012>
2. Join via audio.
One tap mobile:
+61-3-7010-3254..475 099 012#

In order to preserve the security of the webinar, we kindly request that all meeting details and links are kept strictly confidential within your organisation.

We look forward to welcoming you to the webinar.

Calmonovo

- 51 What is the **main** focus of the first paragraph?
- A. to show the achievements of the presenter of the webinar
 - B. to encourage the recipient to persuade others to join the webinar
 - C. to persuade the recipient to sign up for the webinar
 - D. to provide a brief summary of the content covered in the webinar
- 52 'Dr Harmonia Aarav will discuss mindfulness techniques that can be implemented ...' (paragraph 1)
In this sentence, the word 'implemented' could **best** be replaced by
- A. put into operation
 - B. learnt quickly
 - C. developed
 - D. taught to others
- 53 Calmonovo is **most** likely to be
- A. the manager inviting Joanna to the webinar.
 - B. the platform hosting the webinar.
 - C. the company delivering the webinar.
 - D. the person presenting the webinar.

Questions 54–56

The following text is taken from an online forum where students share study advice.

**Samstudent**

Hey, Sam from Ashview University here. I have just received my first group assignment and am hoping for some input on approaching a piece of work like this, not least how to overcome my current state of dread! The deadline is six weeks away but, working with five strangers, I want to be fully prepared for the task ahead.

**Hannah33**

Hi Sam, I can completely empathise with how you're feeling! To help you learn from my mistakes – be sure to organise a meeting with your group as soon as possible. The pressure of leaving assignments to the last minute is much greater when working with others. Effective collaboration can take time to set up. Start by identifying the project goals, setting expectations and allocating tasks strategically to best utilise everyone's individual strengths.

**Cameronstudies**

Hannah33 has given some great pointers, but who will lead the project and guarantee everyone is contributing equally? From experience, you'll need a team leader to ensure people are held accountable for their set tasks being completed comprehensively in a timely way. I'd recommend setting interim deadlines across the six weeks to keep everyone on track for the final submission. Working effectively with others is a key life skill, and if you feel confident in your leadership abilities this could be a great opportunity to get some additional experience for future employment.

- 54 **Hannah33**'s advice is **most** likely based on
- A. previous discussions in the online forum.
 - B. her own previous experiences of group work.
 - C. research into effective collaboration strategies.
 - D. her approach to her current group project.
- 55 **Cameronstudies** suggests 'interim deadlines' should be set.
This means there would be deadlines set
- A. for only the later stages of the project.
 - B. that would apply to only some of the group members.
 - C. that suited the schedule of each member.
 - D. for different stages of the project.
- 56 Why does **Cameronstudies** recommend that **Samstudent** take on the role of team leader?
- A. It will allow the other students to concentrate on fulfilling their specific roles in the project.
 - B. It will ensure that **Samstudent** does not have to contribute more than others in the group.
 - C. It will give **Samstudent** a chance to practise a skill that is valued in the workplace.
 - D. It will force the other students to complete their tasks at the right time.

Questions 57–61

The following text has been adapted from government websites about roadwork permits required by construction businesses.

Section 2: Amend an existing permit

To comply with local and national legislation, all construction businesses are required to have a permit before any digging work may start on public roads.

If you wish to amend an existing permit, you must get written confirmation of approval before the start of any activities.

2.1

To request an amendment to an existing permit, follow the instructions in Section 2.2. You may only request one amendment at a time. If the amendment you wish to make is not listed below, you will need to apply for a new permit, which may take up to 30 calendar days.

Amendments:

- start date
- end date
- specified area. (Please note that consideration of proposed changes to area is limited to the street specified in the permit. Should other streets be affected, a new application must be submitted.)

2.2

1. Log into your business permits account [here](#).
2. The page will show all permits active in your business name.
3. Tick the box next to the permit you wish to amend and click on edit.
4. Select the type of amendment you would like to make.
5. Enter a reason for the amendment. Please share as much relevant information as possible to support your application.
6. Click on submit. Our team will undertake a comprehensive review of your application and respond within 15 business days.
7. If your application is accepted, we will email you a link where you can enter your payment details.
8. Should your request be rejected, you may appeal the decision for up to 30 calendar days following the decision. See Section 4 for details on how to appeal.

57 Section 2 is titled 'Amend an existing permit'.

What is the **most** likely title of the preceding section?

- A. Section 1: Request another amendment
- B. Section 1: Apply for a permit
- C. Section 1: Complaints procedure
- D. Section 1: Submit an appeal

58 Why is it important to apply early for a permit amendment?

- A. to allow time to gather all the information necessary for the application
- B. because applications submitted less than 30 days before the proposed start date will be rejected
- C. to allow time for an application review, a possible appeal or application for a new permit
- D. because there is a waiting period due to the number of applications

59 A business may have multiple roadwork permits.

Which of the following points in Section 2.2 shows this?

- A. 3
- B. 4
- C. 5
- D. 6

60 'Our team will undertake a comprehensive review of your application ...' (Section 2.2)

This means that the team will be

- A. strict.
- B. critical.
- C. impartial.
- D. thorough.

61 What does the text encourage applicants to do to increase the likelihood of a successful permit amendment application?

- A. keep their responses brief
- B. make an appeal via email
- C. include all applicable information
- D. make applications one at a time

Questions 62–64

The following letter is from a customer to an air conditioning company.

To whom it may concern,

I would like to register my dissatisfaction with the air conditioning unit (model No AC15X) that I purchased from your premium range two weeks ago. The unit, falsely boasting ‘practically silent fans’, has been anything but silent. As soon as it is switched on, it whines continuously, disrupting the whole household. This appears to be getting worse each time it is used. Despite several attempts to adjust the settings and to follow the impenetrable troubleshooting guidance on your website, the deafening whirr has not improved.

The fact that this brand-new unit has failed so spectacularly to deliver on its advertised features is unacceptable, particularly as it should have been properly tested by your colleagues on installation.

I have phoned your company’s helpline on multiple occasions, only to be redirected to voicemail, leaving me no choice but to enter into written correspondence in the hope of receiving some response. This poor customer service is also extremely disappointing from an organisation that claims to value its customers.

If this cannot be rectified by the end of this week, either by sending a member of your repair crew to my home or by issuing a replacement, I would like a full refund.

I anticipate receiving a prompt response from you and a resolution to this matter.

Sincerely,

Lionel P. McKenna

- 62 The phrase ‘the impenetrable troubleshooting guidance’ (paragraph 1) suggests that the writer found the guidance
- A. overly detailed.
 - B. hard to locate.
 - C. irrelevant to his problem.
 - D. impossible to follow.
- 63 ‘... leaving me no choice ...’ (paragraph 3)
The writer uses this phrase to
- A. highlight the severity of the issue he is complaining about.
 - B. warn the company of potential future repercussions.
 - C. emphasise that all alternative options have been exhausted.
 - D. provide an explanation for his initial response to the issue.
- 64 The tone of the final sentence can **best** be described as
- A. pessimistic.
 - B. expectant.
 - C. sarcastic.
 - D. hopeful.

Questions 65–68

The following checklist is from an office safety assessment guide.

Checklist

Potential risk factor to evaluate	Action points to consider
<p>Furniture</p> <ul style="list-style-type: none"> • Does the workspace offer sufficient space to meet user needs? • Is the chair adjusted to fit the user? 	<ul style="list-style-type: none"> • Create a more spacious working environment by removing non-essential equipment. • Consider installing new power sockets to ensure equipment can be moved easily. • Ensure chairs have adjustable seat mechanisms; replace or repair chairs that do not meet the required standard. • Arrange regular staff training on adjusting chair settings. Providing employees with information on how to adopt the correct sitting postures is also recommended. Additional guidance on this subject can be found in Appendix B of this guide.
<p>Environment</p> <ul style="list-style-type: none"> • Is the lighting suitable? • Is the level of heat appropriate? • Does the air feel comfortable? 	<ul style="list-style-type: none"> • Allow staff to manage light levels with ease, e.g. using shutters or blinds on windows to control external light sources. • Check that the temperature does not fluctuate; more ventilation may be required, particularly if there is substantial electronic equipment in the office space. • Circulate fresh air where possible as equipment may dry the air. Alternatively, adjust the air flow in the room.
<p>Computer</p> <ul style="list-style-type: none"> • Is the display adjustable? 	<ul style="list-style-type: none"> • Confirm that all monitors can be adjusted to meet user requirements, e.g. graphic work may require a larger display screen.

Managers should check the office space for each member of staff against the risk factors listed above. If employees identify risks, they should record them on the form below.

- 65** Look at the '**Furniture**' section of the checklist.
Which of the action points is **most** different in focus from the other points?
- A. Point 1
 - B. Point 2
 - C. Point 3
 - D. Point 4
- 66** Look at the '**Environment**' section of the checklist. Staff are advised to 'Check that the temperature does not fluctuate ...'
This means they must make sure that the temperature of the work environment
- A. supports the functioning of electrical equipment.
 - B. falls into a range mutually agreed to between staff.
 - C. alternates at set times to improve concentration.
 - D. is consistently maintained at a suitable level.
- 67** Management wants to add the following action point to the checklist:
- Check that the level of noise present is suitable for the workspace.
- In which section should this action point be placed?
- A. Furniture
 - B. Environment
 - C. Computer
 - D. a new category
- 68** Look at the text below the checklist.
What does this suggest about the role of managers and the role of all members of staff?
- A. Managers are solely responsible for ensuring a safe environment for all members of staff.
 - B. Managers must provide a safe environment but all members of staff should take some responsibility too.
 - C. All members of staff are responsible for ensuring managers act upon all possible risk factors.
 - D. All members of staff are responsible for ensuring the environment meets the required standard.

Questions 69–71

The following text is a speech given by an adventurer to a group of high school students.

Choosing adventures wisely

In a world that glorifies grand adventures, it can be easy to overlook the fulfilment that comes with savouring life's smaller moments. I know first-hand that embarking on a monumental journey can offer unparalleled thrills; but I have also learnt that those rare occasions are not enough to sustain deep satisfaction. The true essence of living lies in experiences and adventures that make up the rich tapestry of life. But we must do the 'weaving' to put them there.

Consider the joy of a night spent camping in the countryside, or even in your backyard: successfully pitching your tent, marvelling at the beauty of the star-studded sky and waking up to the sound of birdsong. You notice details otherwise missed in the rush and hurry of daily life. Unlike the relatively fleeting rush of adrenaline from a one-time adventure, like reaching the summit of a mountain, simple encounters with the world around us cultivate enduring gratitude for our surroundings. There are many small adventures, from spending the afternoon exploring a nearby creek and discovering a hidden cove, to simply climbing a large tree in your neighbourhood. These activities enable you to see your surroundings from a completely new vantage point, satisfying the adventurer within.

Preparing for an epic adventure takes dedication, preparation and perseverance. While goals help give our lives purpose, solely focusing on achievement that can only be attained in the future fosters an outcome-oriented view on happiness. We wish time away, chasing distant horizons and forget to enjoy the process of living.

So, while I'm not discouraging you from striving for grand adventures, don't let it be at the expense of recognising the opportunities for greatness in the everyday. What adventure could tomorrow bring for you?



Photograph by Geoff Wols

- 69** The speaker refers to 'weaving' in the first paragraph.
What message does this metaphor convey?
- A.** Wait and adventures will come to you.
 - B.** Give yourself opportunities to have a variety of experiences.
 - C.** Learn to weave for an exciting and life-fulfilling experience.
 - D.** Every single day is an adventure of a different type.
- 70** '... from spending the afternoon exploring a nearby creek and discovering a hidden cove, to simply climbing a large tree in your neighbourhood.' (paragraph 2)
What is the purpose of these examples?
- A.** They indicate that thrills and excitement are transient.
 - B.** They suggest that the concept of adventure is superficial.
 - C.** They diminish the significance of a one-time adventure.
 - D.** They show the potential for adventure in small moments.
- 71** 'While goals help give our lives purpose ...' (paragraph 3)
The speaker uses this phrase to
- A.** acknowledge another opinion.
 - B.** exemplify a novel concept.
 - C.** dismiss differing perspectives.
 - D.** contradict an initial assumption.

Questions 72–75

The following email exchange is between two young people about a swimming instructor training course.

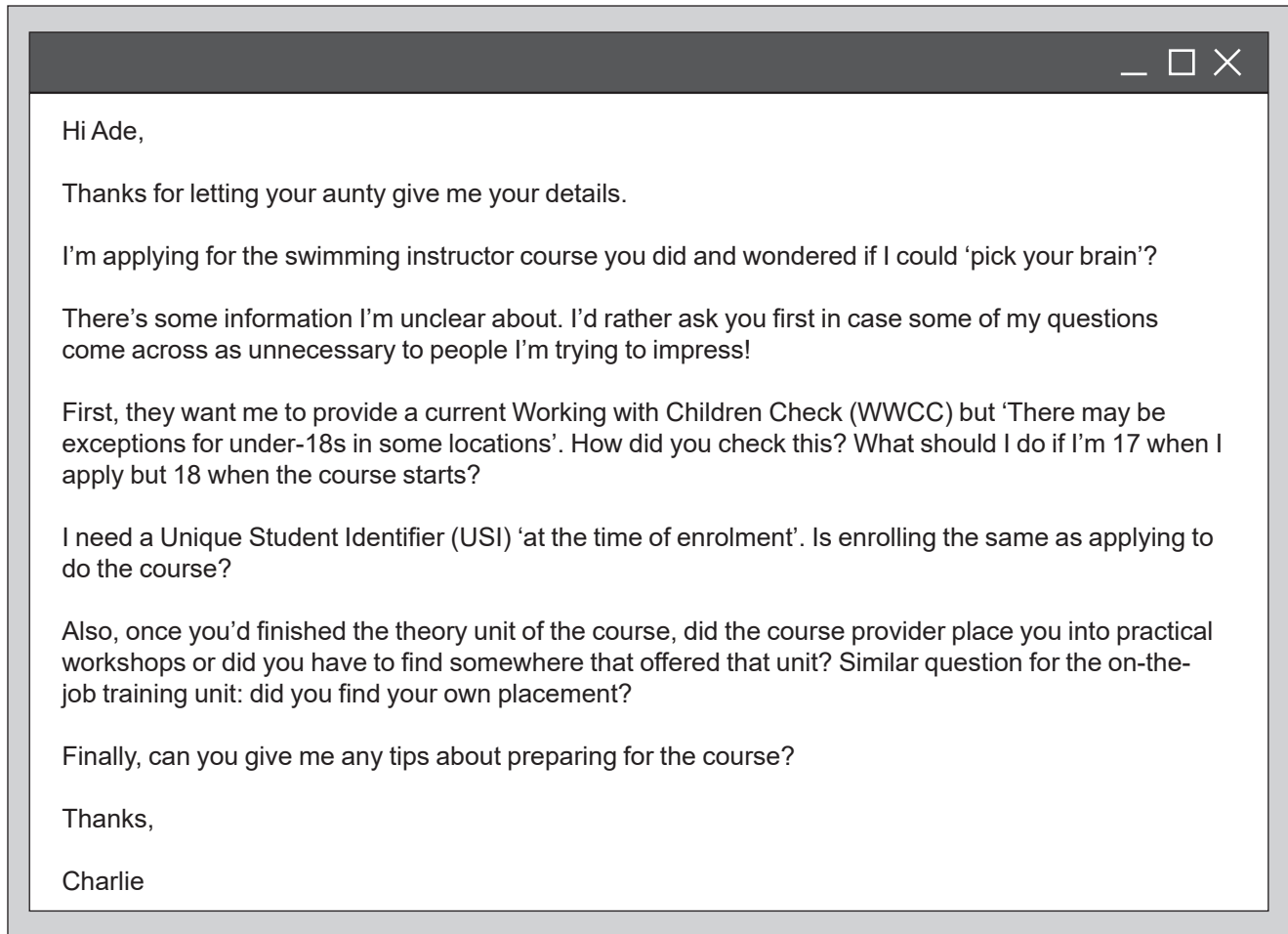

Hi Ade,

Thanks for letting your aunty give me your details.

I'm applying for the swimming instructor course you did and wondered if I could 'pick your brain'?

There's some information I'm unclear about. I'd rather ask you first in case some of my questions come across as unnecessary to people I'm trying to impress!

First, they want me to provide a current Working with Children Check (WWCC) but 'There may be exceptions for under-18s in some locations'. How did you check this? What should I do if I'm 17 when I apply but 18 when the course starts?

I need a Unique Student Identifier (USI) 'at the time of enrolment'. Is enrolling the same as applying to do the course?

Also, once you'd finished the theory unit of the course, did the course provider place you into practical workshops or did you have to find somewhere that offered that unit? Similar question for the on-the-job training unit: did you find your own placement?

Finally, can you give me any tips about preparing for the course?

Thanks,

Charlie

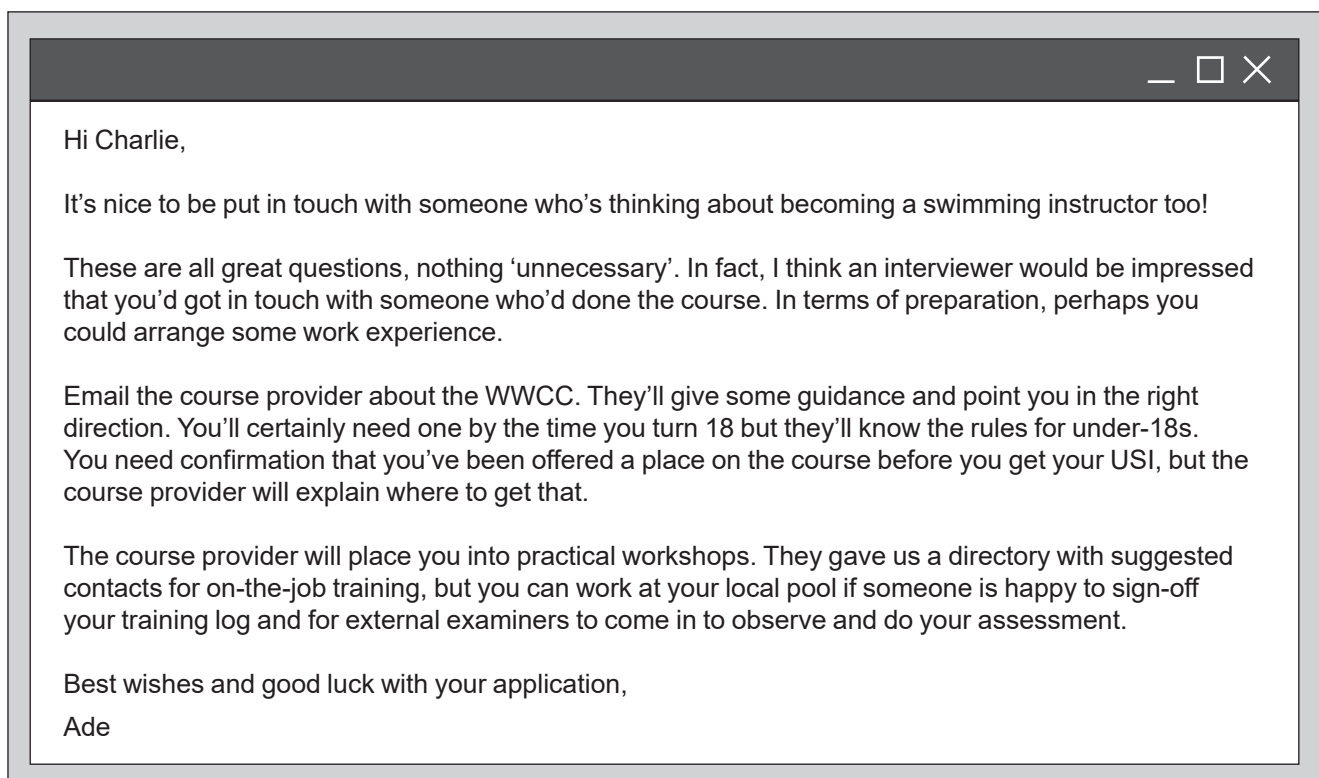

Hi Charlie,

It's nice to be put in touch with someone who's thinking about becoming a swimming instructor too!

These are all great questions, nothing 'unnecessary'. In fact, I think an interviewer would be impressed that you'd got in touch with someone who'd done the course. In terms of preparation, perhaps you could arrange some work experience.

Email the course provider about the WWCC. They'll give some guidance and point you in the right direction. You'll certainly need one by the time you turn 18 but they'll know the rules for under-18s. You need confirmation that you've been offered a place on the course before you get your USI, but the course provider will explain where to get that.

The course provider will place you into practical workshops. They gave us a directory with suggested contacts for on-the-job training, but you can work at your local pool if someone is happy to sign-off your training log and for external examiners to come in to observe and do your assessment.

Best wishes and good luck with your application,

Ade

- 72 What does Charlie want from Ade?
- A. clarification of points left unspecified by the course provider
 - B. tips for making a good impression with the course provider
 - C. details of the content covered in the course
 - D. information about the eligibility criteria for the course
- 73 The exchange between Charlie and Ade could **best** be described as
- A. professional in tone despite their similarity in age.
 - B. formal despite their family connection.
 - C. friendly despite their previous lack of correspondence.
 - D. humorous despite how much Charlie wants the job.
- 74 What is the **main** purpose of paragraph 2 of Ade's email?
- A. to offer Charlie practical support in preparing for the course
 - B. to provide reassurance about concerns expressed in Charlie's email
 - C. to encourage Charlie to contact the interviewer for the course
 - D. to offer Charlie a work experience opportunity
- 75 According to the text, the course provider will
- A. apply for a WWCC on Charlie's behalf.
 - B. email Charlie the link to the WWCC application form.
 - C. issue Charlie with a temporary WWCC.
 - D. advise Charlie on when and how to acquire a WWCC.

Questions 76–79

The following text is taken from a website aimed at students.

The Forgetting Curve

Forgetting can be very frustrating, especially when you're trying to absorb a piece of key information or recall how to do something you learnt only the other day.

Psychologist Hermann Ebbinghaus wanted to explore the reasons behind why we forget, and devised an experiment in which he attempted to recall a list of nonsense syllables after different amounts of time had passed. The results from his research found four key factors that impact upon our ability to remember things:

- Time – a shorter gap between learning something and reviewing helps with longer-term retention.
- Meaning – the greater our engagement with or understanding of information, the better our retention.
- Presentation – the more comprehensive the way information is taught to us, the stronger our retention.
- Emotional response – the level of stress someone experiences can impact upon how well information is retained.

Ebbinghaus produced a visual representation to show how learnt information can be quickly forgotten, known as the Forgetting Curve (Figure 1).

The Forgetting Curve shows the steepest decline in memory occurs following the original point of learning, and that retention continues to diminish as time goes on.

Subsequent researchers showed that one way to enhance the power of our memory is by 'spaced learning' – reviewing information shortly after you have learnt it and then regularly going forward (Figure 2). By reviewing previously learnt information at the point our recall has started to decline, but before we essentially need to re-learn it, we can delay the forgetting process significantly. Practising this repeatedly and introducing larger gaps between reviewing sessions enable us to retain the information for far longer and identify any gaps in knowledge along the way.

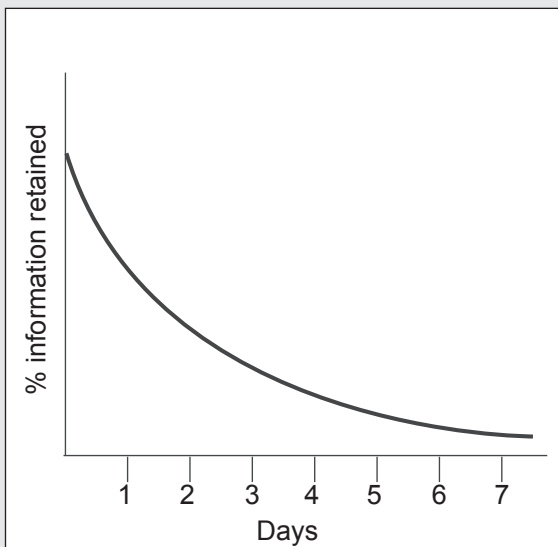

Figure 1 Ebbinghaus's Forgetting Curve

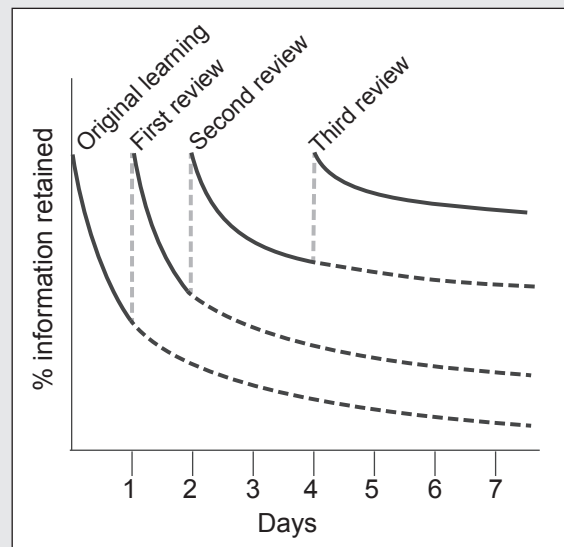

Figure 2 Using spaced learning to enhance the retention of information

- 76** Which of the following assumptions **most** likely formed the basis of Ebbinghaus's experiment?
- A.** Forgetting is preventable with the implementation of strategies.
 - B.** Individuals are able to retain differing amounts of information.
 - C.** Some types of information are easier to remember than others.
 - D.** The retention of learnt information declines over time.
- 77** According to the results of Ebbinghaus's research, emotional response is a factor that affects memory retention.
- In the summary of this factor, the writer has assumed that the reader
- A.** has personal experience of stress impacting upon their retention of information.
 - B.** can infer the likely nature of the relationship between stress and memory retention.
 - C.** does not need to know how stress affects the retention of information.
 - D.** will struggle to understand exactly how stress impacts upon memory retention.
- 78** According to the text, when is the rate of information loss **most** rapid?
- A.** more than a week after learning
 - B.** between five and seven days after learning
 - C.** in the initial days directly following learning
 - D.** after an extensive period of time has elapsed since learning
- 79** Students have learnt some definitions of unfamiliar words and will be tested on them in a month. They are deciding upon a revision strategy.
- According to the text, which strategy is likely to be **most** beneficial?
- A.** Allow at least a week for the initial learning to become embedded before attempting to review learning material.
 - B.** Review the full list of words in short, frequent sessions throughout the month and increase the intervals between sessions over time.
 - C.** Dedicate a large block of time to mastering the definition of one word at a time before moving on to the next word.
 - D.** Revise the definitions of the full list of words straight after learning them and then revisit them in the days before the test.

Questions 80–83

The following extract is from *One Native Life*, a memoir by Richard Wagamese, a Canadian Indigenous writer.

Bringing in the Sheaves

I learnt to drive when I was ten, on an old grey Allis-Chalmers tractor. My job was to pull the wagon while the men of my adopted family forked sheaves of wheat at threshing time. I had to drive carefully, so that the men on the top of the load were safe.

Threshing time was big. Hereditary farms like my adopted grandfather's still flourished in Huron County back then, and there was a strong sense of community along the dusty concession roads. Neighbours had been neighbours for generations, and folks looked out for each other. Help was always needed for one thing or another and, in those times, help was always there.

Bringing in the crop was an event. People came from all along the line to pitch in. It gave the work the feel of importance, and I was proud to be part of it. The only thing I could do at my age was drive, and I took to it quickly. My driving had to be smooth and steady. When I turned I made sure I did it evenly, conscious of both the load and the men atop it. When the wagon was full I drove up the lane to the barn, where the threshing machine waited. I could hear the men chatting and laughing on the wagon behind me.

80 'Hereditary farms like my adopted grandfather's still flourished in Huron County back then ...' (paragraph 2)

Wagamese includes this information to

- A. emphasise the ongoing success of his adopted grandfather's farm.
- B. explain what set farming in Huron County apart from other places.
- C. imply that traditional family farms are no longer as successful.
- D. suggest that a return to this way of farming would be beneficial.

81 The tone of paragraph 2 is

- A. nostalgic.
- B. melancholic.
- C. critical.
- D. descriptive.

82 Wagamese presents 'Threshing time' (paragraph 2) as

- A. an intrinsic part of daily life on the farm.
- B. an irregularity that local people had to adapt to.
- C. a trial only to be overcome with hard work.
- D. an occasion that was central to community life.

83 What **most** strongly contributed to Wagamese's sense of pride?

- A. the young age at which he began to help
- B. the sense of contributing to a collective effort
- C. the importance of his role as the driver
- D. the response of the men on the wagon

Questions 84–86

The following recipe is from *Meat Free Mowgli: Simple and Delicious Plant-Based Indian Meals* by Nisha Katona.

Jackfruit Jalfrezi

This fruity, dairy-free curry is simplicity itself. It's quite hot, but you can tone down the heat by piercing the green chilli rather than slicing it, if you wish. A good jalfrezi should be tongue-tinglingly spicy though, so embrace the heat if you can.



SERVES 4

- 3 tbsp vegetable oil
- 2 brown onions, finely chopped
- 5 cm piece of fresh ginger, peeled and grated
- 3 garlic cloves, minced
- 2 x 400 g cans of jackfruit, drained
- 2 tbsp garam masala
- 2 tsp ground cumin
- 1 tsp ground turmeric
- 1/4 tsp chilli powder
- 1 x 400 g can of chopped tomatoes
- 2 capsicums, deseeded and roughly chopped
- 1 large green chilli, deseeded and thinly sliced
- 1 tsp salt
- 1 tsp sugar
- 200 mL water

1. Heat the oil in a large saucepan that has a lid over a medium heat. When hot, add the onions, ginger and garlic, and cook for 7–8 minutes, or until golden brown.
2. Add the drained jackfruit and stir to combine, then cook for 3–4 minutes, or until starting to colour.
3. Add the spices, chopped tomatoes, capsicums, green chilli, salt and sugar, along with the measured water. Give everything a good stir together, then turn the heat to low, cover and gently simmer for 15–20 minutes, or until the jackfruit is cooked through and tender.

- 84** What assumption is made in the first sentence of the introduction to the recipe?
- A.** Readers will not struggle to make the recipe.
 - B.** Readers may have made more complex recipes before.
 - C.** Readers may not be familiar with every ingredient in the recipe.
 - D.** Readers will perceive the recipe as more complex than it is.
- 85** What does the writer think about adjusting the heat level of the curry?
- A.** The reader should increase the heat beyond the level of the recipe if they can.
 - B.** The heat of the dish can be varied and it is best at a level that the reader finds comfortable.
 - C.** The heat can be reduced but the authenticity of the dish will be compromised.
 - D.** The reader needs advice on how to adjust the heat level without compromising flavour.
- 86** The timings given in steps 1 to 3 are
- A.** approximate guidelines as to how long each step should take.
 - B.** designed to be followed exactly for optimum results.
 - C.** variable depending upon the level of heat the reader chooses to use.
 - D.** the minimum time needed to ensure the curry is properly cooked.

Questions 87–90

The following letter is from a company to its employees reporting on the results of a survey.

Dear valued colleagues,

Annual employee satisfaction survey

We are writing to express our gratitude for your recent participation in our annual online employee satisfaction survey across all departments of the company. Your feedback provides important insights to enable the senior management team to continue to create a supportive and inclusive environment for all staff and to be made aware of areas for improvement.

We strongly believe that the collective voice of our employees is vital to our success as a company and we are thrilled to see 82% of employees completed the survey last month. This survey has been rolled out annually for the past five years to monitor employees' perceptions of how they are treated in their roles and across the company.

Overall, 74% of employees reported that they felt satisfied with their current role. This is a 7% increase from the previous year, which shows we are continuing to head in the right direction.

A core aim of the survey was to hear your thoughts on the recent modifications to shift hours, which were introduced to increase staff flexibility and enhance our response times to customers in need of maintenance services. The survey found 48% of respondents felt positive about this recent change.

Other key findings include:

- 85% reported receiving necessary support from team leaders
- 91% reported receiving appropriate levels of training
- 76% reported that morale is high
- 74% reported that employees are treated fairly
- 70% reported having a good work/life balance.

The results of the survey have been shared with the senior management team, who will use the information to guide current processes and future changes effectively.

Thank you again for your time contributing to our annual employee satisfaction survey and for sharing your feedback. Our employees are what make our company great.

Kind regards,

Human Resources

- 87 The letter is **mostly** focused on
- A. explaining the rationale for the most recent company survey.
 - B. highlighting the importance of employees participating.
 - C. reporting the insights generated by respondents.
 - D. describing the history of conducting the survey at the company.
- 88 'We strongly believe that the collective voice of our employees is vital to our success as a company ...' (paragraph 2)
- What impression of the company does the writer create in this sentence?
- A. The views of all employees, regardless of position within the company, are held in the same esteem.
 - B. The majority of employees agree with the decision-making processes of management.
 - C. Management present the views of their employees as their own.
 - D. Any changes to the company are approved by employees before they are implemented.
- 89 According to the text, the company is particularly keen to understand its employees' views about
- A. the effectiveness of training packages available.
 - B. how to improve the experience of customers at first contact.
 - C. how to ensure a consistent balance between work and life commitments.
 - D. the impact of the alterations that have been made to working patterns.
- 90 The findings of the survey suggest the **overall** outlook of the workforce is
- A. positive about every aspect of work.
 - B. mostly positive about work.
 - C. neutral in their attitude about work.
 - D. negative about the majority of aspects of work.

Questions 91–93

The following extract is from the introductory chapter of *Always Will Be: Stories of Goori sovereignty from the futures of the Tweed*, a series of short stories by Mykaela Saunders, a Koori/Goori and Lebanese writer.

From the beginning of its creation period – the Budherum, or the Dreaming – and all the way up until recently, the Tweed Valley was green and wet and teeming with all sorts of life. This is a place of hot sun, fast winds and torrential rains, where the salt water from the ocean mixes with the sweet waters from the hills and valleys. The weather is mercurial. Storms and sticky days and thunder and rainbows are always coming and going, simmering the whole place into a bubbling force of movement and renewal. There's never a dull moment around here. Cyclones sometimes whistle round the coast, playing the place like a singing bowl, bringing storms and floods and heatwaves that shimmer on their tails. Like a weather glass that changes at the will of the wind and tides, it's a country that transforms its moods and types of magic several times a day, and that's because it's as alive as everything that lives in it. As alive as you and me.

Within the Tweed Valley are rivers and broadwaters that feed green and muddy estuaries. When the tide comes inland via the rivers, the water floods in from the ocean and encircles the little mangrove islands, which are not purely aquatic, but not quite solid ground either. These muddy islands are surrounded by the river, which is circumscribed by solid land. The river slops and swills around the estuaries, nourishing itself in its motions. At low tide, the waters swim back out to clean themselves in the ocean, and they always return, refreshed, at high tide.

- 91 In paragraph 1, Saunders describes the weather in the Tweed Valley as 'mercurial'. Which quotation from the same paragraph **most** closely repeats this idea?
- A. 'There's never a dull moment around here.'
 - B. 'Cyclones sometimes whistle round the coast ...'
 - C. '... it's a country that transforms its moods and types of magic several times a day ...'
 - D. '... it's as alive as everything that lives in it.'
- 92 'Storms and sticky days and thunder and rainbows are always coming and going, simmering the whole place into a bubbling force of movement and renewal.' (paragraph 1)
Saunders uses imagery in this sentence to create a sense of
- A. elements combining to produce something greater and more powerful.
 - B. elements combining in a controlled and gentle way.
 - C. dangerous and temperamental elements building up over time.
 - D. different elements competing for overall dominance.
- 93 In paragraph 2, Saunders presents the tides as
- A. a recurring threat.
 - B. a passive influence.
 - C. a healthy natural cycle.
 - D. a friendly life-giving force.

Questions 94–97

The following text is from a webpage advertising workshops for developing public speaking skills.

Why are public speaking skills so important?

Being able to speak in public with confidence and eloquence is an essential and often overlooked skill.

According to our most recent poll, only 19% of 16–18-year-olds felt they had strategies to help them navigate a wide range of public speaking scenarios; 35% felt confident preparing for interviews and 15% expressed concern about working with groups of new people in a workplace or new education setting.



We all want our young people to succeed and thrive. That's why we're passionate about boosting their public speaking skills with our engaging public speaking workshop.

What do we offer?

The specialised one-day program incorporates games, group work and real-life scenarios, suitable for preparing older students for life beyond school. Delivered in school, workshop sessions include:

- preparing for group work
- mastering the art of debate
- interview tips and techniques.

Why choose us?

Our experienced and enthusiastic team are experts at helping students explore a range of skills and strategies in a safe, secure and supportive environment so that every student has the opportunity to speak up and shine with our inspiring workshop.

Here are just a few of the reviews given by satisfied teachers and students.

'The workshop was really engaging and pitched just right for students. They all came away absolutely buzzing and full of new confidence in their abilities!'

'I was super nervous about talking in front of people, but I had so much fun I kind of forgot to be nervous by the end.'

'I liked the way they made everything fun but also relevant to us. I was worried it would be a bit basic but, actually, I think it'll help me feel more in control when I go for interviews.'

'I can see how I'll use the skills I've learnt today in the future. It's not something we've done a lot of before, so I found it really helpful.'

Sign up!

So, what are you waiting for? Book one of our public speaking workshops or contact us to chat to one of our expert team now.

- 94 The inclusion of statistics in paragraph 2 shows
- A. the teaching methods of the workshop are informed by students' views.
 - B. the need for a workshop that addresses the issues.
 - C. why so many people choose the workshop.
 - D. that people underestimate the value of public speaking skills.
- 95 'We all want our young people to succeed and thrive.' (paragraph 3)
The use of the pronoun 'we' in this sentence indicates that the company
- A. assumes the reader's values match its own.
 - B. believes that these values are a top priority.
 - C. comprises many individuals who all share this view.
 - D. sympathises with the views of the reader.
- 96 All of the reviews suggest how the workshop
- A. made students feel differently about their skills.
 - B. allowed public speaking to be explored in a fun way.
 - C. addressed the concerns that students may have had.
 - D. provided an appropriate level of challenge.
- 97 Who is **most** likely the target audience of this text?
- A. students who do not feel confident about their public speaking skills
 - B. students who will soon be taking part in interviews
 - C. teachers who want to learn how best to teach public speaking skills
 - D. teachers who want to give their students access to training

Questions 98–100

The following online article is about using social media for business growth.

Social media: an essential tool for business growth

In today's digital world, embracing the marketing opportunities offered by social media should have a place in your business plan – whether you are an established, thriving business or a new start-up looking to gather momentum and secure your place in the market. From ordering food to booking flights, everything is accessible at the consumer's fingertips; businesses without an online presence risk becoming irrelevant all too quickly. Irrespective of whether you run a small cafe or a multi-franchised business, the benefits of engaging with social media are multi-faceted.

1. Attract attention

In the initial phases of building a new brand, a strong social media presence boosts visibility and ultimately revenue. Social Media Optimisation (SMO) is a strategy implemented in digital marketing to manage and magnify an organisation's online presence. Effective use of SMO (e.g. through regular or topical content sharing) increases brand awareness and can generate traffic towards your site.

2. Build loyalty

Already have a loyal customer base? Social media is important for the warm market too. Sharing relatable and engaging social media content is a sure-fire way to stay relevant and remind existing customers of what's on offer.

3. Showcase your brand

It is increasingly common for customers to turn to social media when making decisions, such as choosing a restaurant. Your social media presence could be the first thing a potential new patron sees when looking up 'Greek restaurants in Melbourne' for example. The content you choose to share online should highlight your Unique Selling Point (USP) and show your brand in its best light.

4. Encourage engagement

Social media is designed to be ... social. With most platforms allowing for instant interaction and feedback, there is no reason not to connect with your digital audience. Many platforms include features like 'live streaming', 'stories', or 'Q&A' and these facilitate perfect opportunities for conducting market research or for soft launching new products. Be sure to experiment with ways to interact with your followers and you'll soon see which methods are most successful.

Social media is undoubtedly a powerful tool for business growth. As it becomes increasingly integrated into our daily routine, consumers will continue to look to emerging social platforms to discover more about brand identity or to make purchasing decisions. Give your business the inside track with a robust social media presence.

- 98 Which of the following is closest in meaning to ‘magnify’ as it is used in the ‘**Attract attention**’ section?
- A. expand
 - B. focus
 - C. scrutinise
 - D. streamline
- 99 In the section ‘**Build loyalty**’, the phrase ‘warm market’ refers to customers who
- A. already have a relationship with a business.
 - B. prioritise using their preferred brand over cost.
 - C. particularly respond to social media content.
 - D. have interacted with social media but not yet made a purchase.
- 100 The ‘**Encourage engagement**’ section of the article advises an approach that is
- A. radical.
 - B. prescriptive.
 - C. responsive.
 - D. well-established.

This page is blank.

This page is blank.

Acknowledgements

Page 3 (image): Pressmaster, www.shutterstock.com/image-photo/three-children-aprons-sitting-by-table-1149710210; viewed 27 February 2025.

Page 3 (image): Yuri, A, www.shutterstock.com/image-photo/plants-community-service-volunteering-grouppark-2256661267; viewed 27 February 2025.

Page 40 (image): Wols, G, www.alamy.com/campfire-at-night-with-milky-way-in-the-sky-image438008353.html; viewed 27 February 2025.

Page 46 (text): Wagamese, R 2009, *One Native Life: a memoir*, Douglas & McIntyre Ltd (2013), Vancouver; reprinted with permission from the publisher.

Page 48 (text, recipe): Katona, N 2022, *Meat Free Mowgli: Simple & Delicious Plant-Based Indian Meals*, Nourish Books, London. Reproduced with permission of the Licensor through PLSclear.

Page 48 (image): Sathe, S, www.alamy.com/jackfruit-masala-sabji-or-fanas-sabzi-or-indian-style-spicy-kathalcurry-served-in-a-bowl-or-karahi-selective-focus-image432540064.html.

Page 52 (text): Saunders, M 2024, *Always Will Be: Stories of Goori sovereignty from the futures of the Tweed*, University of Queensland Press, St Lucia, Queensland. Copyright © Mykaela Saunders, 2024. The Work is made available for viewing for personal use. All other rights are reserved by UQP.

Page 54 (image): Plavalaguna, D, <https://www.pexels.com/photo/man-in-sweatshirt-in-front-of-people-6150527>; viewed 27 February 2025.