

Victorian Certificate of Education
2015

FURTHER MATHEMATICS
Written examination 1

Friday 30 October 2015

Reading time: 2.00 pm to 2.15 pm (15 minutes)

Writing time: 2.15 pm to 3.45 pm (1 hour 30 minutes)

MULTIPLE-CHOICE QUESTION BOOK

Structure of book

<i>Section</i>	<i>Number of questions</i>	<i>Number of questions to be answered</i>	<i>Number of modules</i>	<i>Number of modules to be answered</i>	<i>Number of marks</i>
A	13	13			13
B	54	27	6	3	27
					Total 40

- Students are permitted to bring into the examination room: pens, pencils, highlighters, erasers, sharpeners, rulers, one bound reference, one approved graphics calculator or approved CAS calculator or CAS software and, if desired, one scientific calculator. Calculator memory DOES NOT need to be cleared.
- Students are NOT permitted to bring into the examination room: blank sheets of paper and/or correction fluid/tape.

Materials supplied

- Question book of 37 pages with a detachable sheet of miscellaneous formulas in the centrefold.
- Answer sheet for multiple-choice questions.
- Working space is provided throughout the book.

Instructions

- Detach the formula sheet from the centre of this book during reading time.
- Check that your **name** and **student number** as printed on your answer sheet for multiple-choice questions are correct, **and** sign your name in the space provided to verify this.
- Unless otherwise indicated, the diagrams in this book are **not** drawn to scale.

At the end of the examination

- You may keep this question book.

Students are NOT permitted to bring mobile phones and/or any other unauthorised electronic devices into the examination room.

THIS PAGE IS BLANK

SECTION A**Instructions for Section A**

Answer **all** questions in pencil on the answer sheet provided for multiple-choice questions.

Choose the response that is **correct** for the question.

A correct answer scores 1, an incorrect answer scores 0.

Marks will **not** be deducted for incorrect answers.

No marks will be given if more than one answer is completed for any question.

Core: Data analysis**Question 1**

The stem plot below displays the average number of decayed teeth in 12-year-old children from 31 countries.

key: 0|2 = 0.2

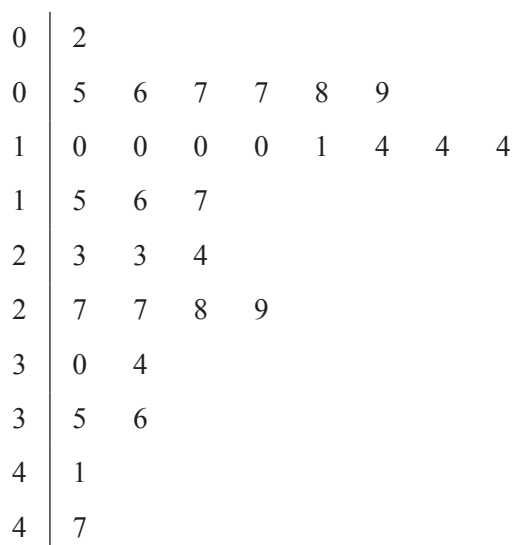

Data: Gapminder

Based on this stem plot, the distribution of the average number of decayed teeth for these countries is best described as

- A. negatively skewed with a median of 15 decayed teeth and a range of 45
- B. positively skewed with a median of 15 decayed teeth and a range of 45
- C. approximately symmetric with a median of 1.5 decayed teeth and a range of 4.5
- D. negatively skewed with a median of 1.5 decayed teeth and a range of 4.5
- E. positively skewed with a median of 1.5 decayed teeth and a range of 4.5

Question 2

For an ordered set of data containing an odd number of values, the middle value is always

- A. the mean.
- B. the median.
- C. the mode.
- D. the mean and the median.
- E. the mean, the median and the mode.

Question 3

The dot plot below displays the difference between female and male life expectancy, in years, for a sample of 20 countries.

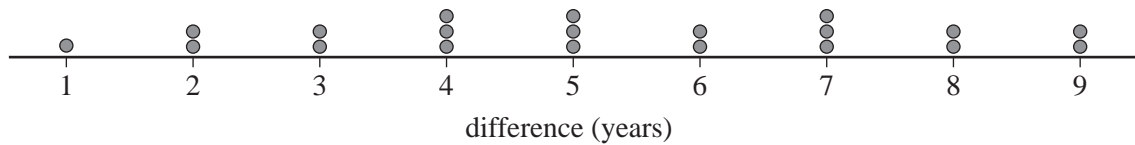

The mean (\bar{x}) and standard deviation (s) for this data are

- A. mean = 2.32 standard deviation = 5.25
- B. mean = 2.38 standard deviation = 5.25
- C. mean = 5.0 standard deviation = 2.0
- D. mean = 5.25 standard deviation = 2.32
- E. mean = 5.25 standard deviation = 2.38

Use the following information to answer Questions 4 and 5.

The foot lengths of a sample of 2400 women were approximately normally distributed with a mean of 23.8 cm and a standard deviation of 1.2 cm.

Question 4

The expected number of these women with foot lengths less than 21.4 cm is closest to

- A. 60
- B. 120
- C. 384
- D. 2280
- E. 2340

Question 5

The standardised foot length of one of these women is $z = -1.3$

Her actual foot length, in centimetres, is closest to

- A. 22.2
- B. 22.7
- C. 25.3
- D. 25.6
- E. 31.2

Use the following information to answer Questions 6 and 7.

In New Zealand, rivers flow into either the Pacific Ocean (the Pacific rivers) or the Tasman Sea (the Tasman rivers).

The boxplots below can be used to compare the distribution of the lengths of the Pacific rivers and the Tasman rivers.

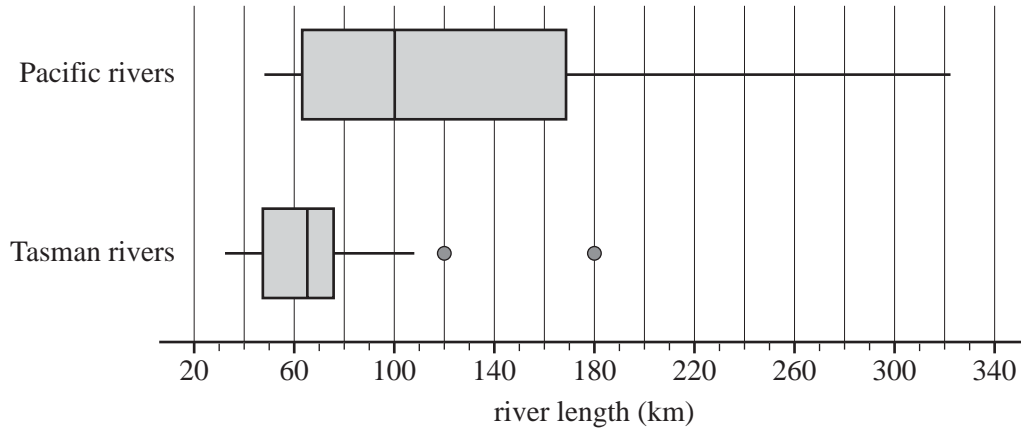

Source: *The New Zealand Yearbook*, 1982

Question 6

The five-number summary for the lengths of the Tasman rivers is closest to

- A. 32, 48, 64, 76, 108
- B. 32, 48, 64, 76, 180
- C. 32, 48, 64, 76, 322
- D. 48, 64, 97, 169, 180
- E. 48, 64, 97, 169, 322

Question 7

Which one of the following statements is **not** true?

- A. The lengths of two of the Tasman rivers are outliers.
- B. The median length of the Pacific rivers is greater than the length of more than 75% of the Tasman rivers.
- C. The Pacific rivers are more variable in length than the Tasman rivers.
- D. More than half of the Pacific rivers are less than 100 km in length.
- E. More than half of the Tasman rivers are greater than 60 km in length.

Question 8

A dot plot for a set of data is shown below.

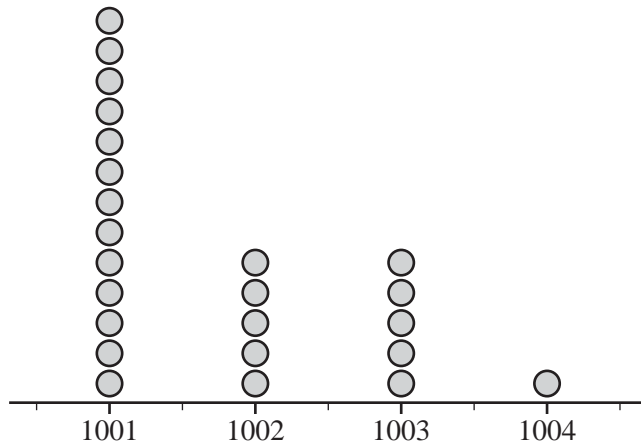

Which one of the following boxplots would best represent the dot plot above?

A.

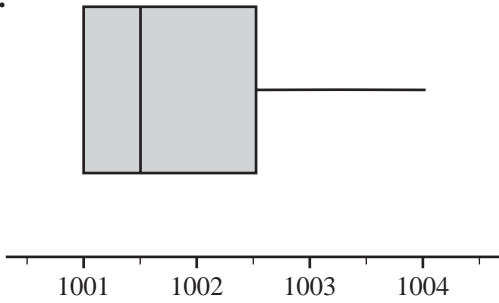

B.

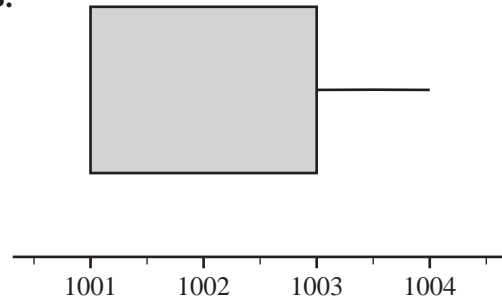

C.

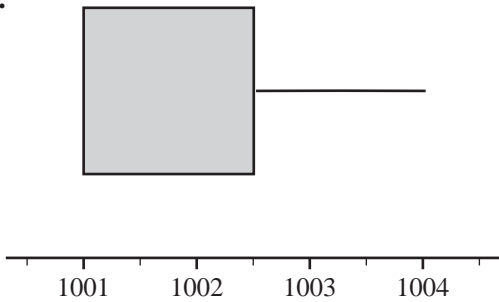

D.

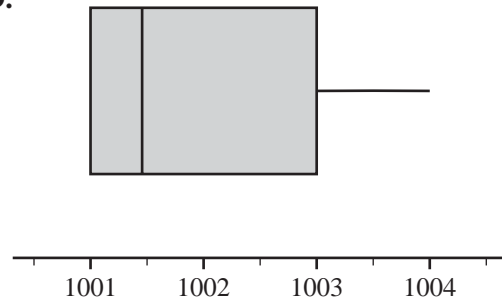

E.

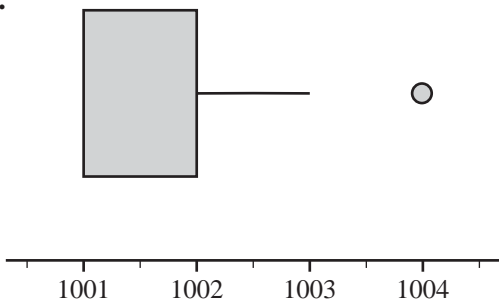

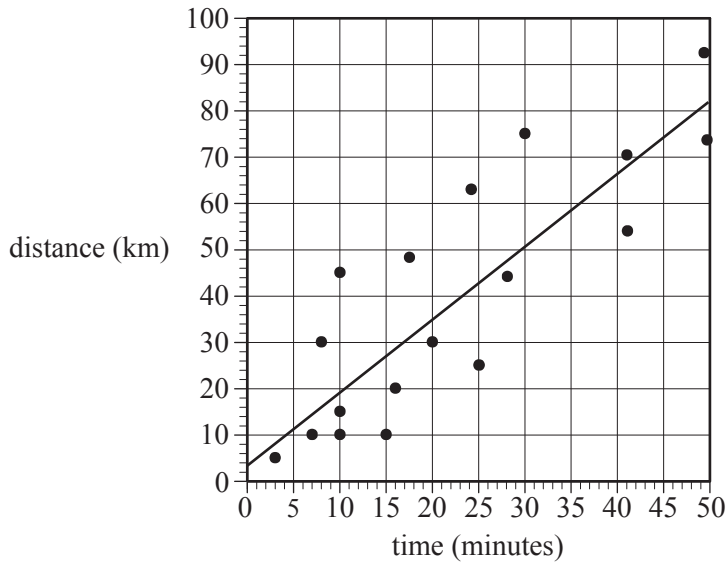
Question 9

A least squares regression line has been fitted to the scatterplot above to enable *distance*, in kilometres, to be predicted from *time*, in minutes.

The equation of this line is closest to

- A. $distance = 3.5 + 1.6 \times time$
- B. $time = 3.5 + 1.6 \times distance$
- C. $distance = 1.6 + 3.5 \times time$
- D. $time = 1.8 + 3.5 \times distance$
- E. $distance = 3.5 + 1.8 \times time$

Question 10

For a set of bivariate data that involves the variables x and y :

$$r = -0.47, \quad \bar{x} = 1.8, \quad s_x = 1.2, \quad \bar{y} = 7.2, \quad s_y = 0.85$$

Given the information above, the least squares regression line predicting y from x is closest to

- A. $y = 8.4 - 0.66x$
- B. $y = 8.4 + 0.66x$
- C. $y = 7.8 - 0.33x$
- D. $y = 7.8 + 0.33x$
- E. $y = 1.8 + 5.4x$

Question 11

A log transformation is used to linearise the relationship between the *weight* of a mouse, in grams, and its *age*, in weeks.

When a least squares regression line is fitted to the transformed data, its equation is

$$weight = -7 + 30 \log_{10}(age)$$

This equation predicts that a mouse aged five weeks has a weight, in grams, that is closest to

- A. 14
- B. 21
- C. 23
- D. 41
- E. 143

Question 12

The time series plot below charts the number of calls per year to a computer help centre over a 10-year period.

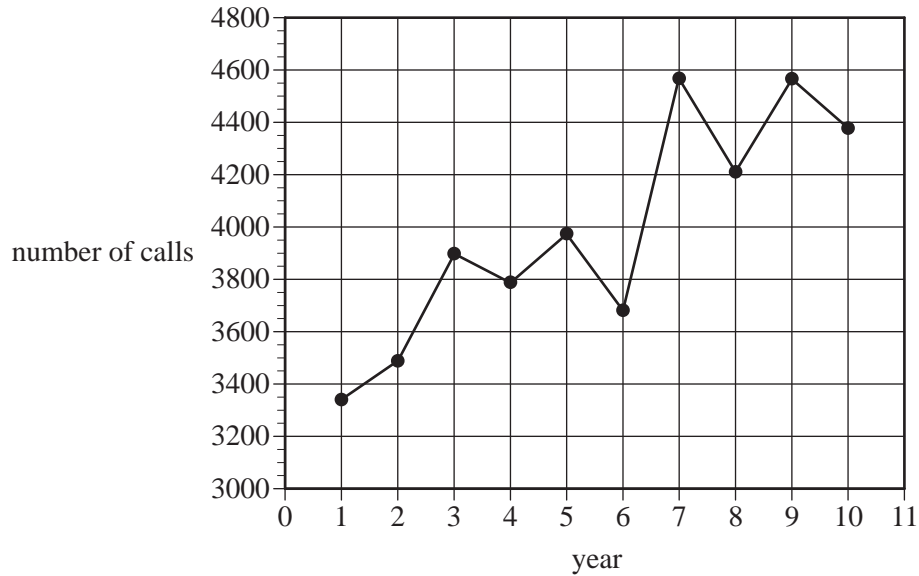

Using five-median smoothing, the smoothed number of calls in year 6 was closest to

- A. 3500
- B. 3700
- C. 3800
- D. 4000
- E. 4200

Question 13

The quarterly seasonal indices for tractor sales for a supplier are displayed in Table 1.

Table 1

Quarter number	1	2	3	4
Seasonal index	1.6	0.6	0.7	1.1

The quarterly tractor sales in 2014 for this supplier are displayed in Table 2.

Table 2

Quarter number	1	2	3	4
Sales (tractors sold)	2800	1032	875	759

The sales data in Table 2 is to be deseasonalised before a least squares regression line is fitted.

The equation of this least squares regression line is closest to

- A. $deseasonalised\ sales = 0.32 + 910 \times quarter\ number$
- B. $deseasonalised\ sales = 370 - 2300 \times quarter\ number$
- C. $deseasonalised\ sales = 910 + 0.32 \times quarter\ number$
- D. $deseasonalised\ sales = 2300 - 370 \times quarter\ number$
- E. $deseasonalised\ sales = 2300 - 0.32 \times quarter\ number$

SECTION B**Instructions for Section B**

Select **three** modules and answer **all** questions within the modules selected in pencil on the answer sheet provided for multiple-choice questions.

Show the modules you are answering by shading the matching boxes on your multiple-choice answer sheet **and** writing the name of the module in the box provided.

Choose the response that is **correct** for the question.

A correct answer scores 1, an incorrect answer scores 0.

Marks will **not** be deducted for incorrect answers.

No marks will be given if more than one answer is completed for any question.

Module	Page
Module 1: Number patterns	10
Module 2: Geometry and trigonometry	13
Module 3: Graphs and relations	18
Module 4: Business-related mathematics	23
Module 5: Networks and decision mathematics	26
Module 6: Matrices	33

Module 1: Number patterns

Before answering these questions you must **shade** the Number patterns box on the answer sheet for multiple-choice questions and write the name of the module in the box provided.

Question 1

The first four terms in a geometric sequence are: 5, 10, 20, 40, ...

The fifth term in this sequence is

- A. 45
- B. 50
- C. 60
- D. 80
- E. 100

Question 2

The second term of a Fibonacci-related sequence is 36 and the third term is 72.

The first term of this sequence is

- A. 2
- B. 6
- C. 18
- D. 36
- E. 108

Question 3

A town has a population of 200 people when a company opens a large mine.

Due to the opening of the mine, the town's population is expected to increase by 50% each year.

Let P_n be the population of the town n years after the mine opened.

The expected growth in the town's population can be modelled by

- A. $P_{n+1} = P_n + 100$ $P_0 = 200$
- B. $P_{n+1} = P_n + 100$ $P_1 = 300$
- C. $P_{n+1} = 0.5P_n$ $P_0 = 200$
- D. $P_{n+1} = 1.5P_n$ $P_0 = 300$
- E. $P_{n+1} = 1.5P_n$ $P_1 = 300$

Question 4

The amount added to a new savings account each month follows a geometric sequence.

In the first month, \$64 was added to the account.

In the second month, \$80 was added to the account.

In the third month, \$100 was added to the account.

Assuming this sequence continues, the total amount that will have been added to this savings account after five months is closest to

- A. \$155
- B. \$195
- C. \$370
- D. \$400
- E. \$525

Question 5

A family bought a country property.

At the end of the first year, there were two thistles per hectare on the property.

At the end of the second year, there were six thistles per hectare on the property.

At the end of the third year, there were 18 thistles per hectare on the property.

Assume the number of thistles per hectare continues to follow a geometric pattern of growth.

At the end of the seventh year, the number of thistles per hectare is expected to be

- A. 972
- B. 1458
- C. 2916
- D. 4374
- E. 8748

Question 6

Miki is competing as a runner in a half-marathon.

After 30 minutes, his progress in the race is modelled by the difference equation

$$K_{n+1} = 0.99K_n + 250 \quad K_{30} = 7550$$

where $n \geq 30$ and K_n is the total distance Miki has run, in metres, after n minutes.

Using this difference equation, the total distance, in metres, that Miki is expected to have run 32 minutes after the start of the race is closest to

- A. 7650
- B. 7725
- C. 7800
- D. 7900
- E. 8050

Question 7

A plant was 80 cm tall when planted in a garden.

After it was planted in the garden, its height increased by 16 cm in the first year.

It grew another 12 cm in the second year and another 9 cm in the third year.

Assuming that this pattern of geometric growth continues, the plant will grow to a maximum height of

- A. 64 cm
- B. 128 cm
- C. 144 cm
- D. 320 cm
- E. 400 cm

Question 8

A_n is the n th term in a sequence.

Which one of the following expressions does **not** define a geometric sequence?

- A. $A_{n+1} = n$ $A_0 = 1$
- B. $A_{n+1} = 4$ $A_0 = 4$
- C. $A_{n+1} = A_n + A_n$ $A_0 = 3$
- D. $A_{n+1} = -A_n$ $A_0 = 5$
- E. $A_{n+1} = 4A_n$ $A_0 = 2$

Question 9

Paul has to replace 3000 m of fencing on his farm.

Let F_n be the length, in metres, of fencing left to replace after n weeks.

The difference equation

$$F_{n+1} = 0.95F_n + a \quad F_0 = 3000$$

can be used to calculate the length of fencing left to replace after n weeks.

In this equation, a is a constant.

After one week, Paul still has 2540 m of fencing left to replace.

After three weeks, the length of fencing, in metres, left to replace will be closest to

- A. 1310
- B. 1380
- C. 1620
- D. 1690
- E. 2100

Module 2: Geometry and trigonometry

Before answering these questions you must **shade** the Geometry and trigonometry box on the answer sheet for multiple-choice questions and write the name of the module in the box provided.

Question 1

The top of a table is in the shape of a trapezium, as shown below.

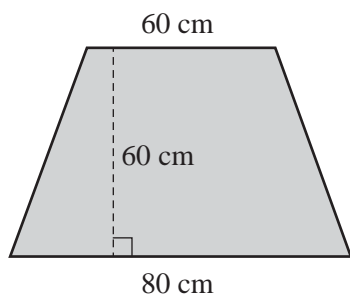

The area of the tabletop, in square centimetres, is

- A. 200
- B. 260
- C. 4200
- D. 4800
- E. 288 000

Question 2

A one-on-one basketball court is a composite shape made up of a rectangle and a semicircle, as shown below.

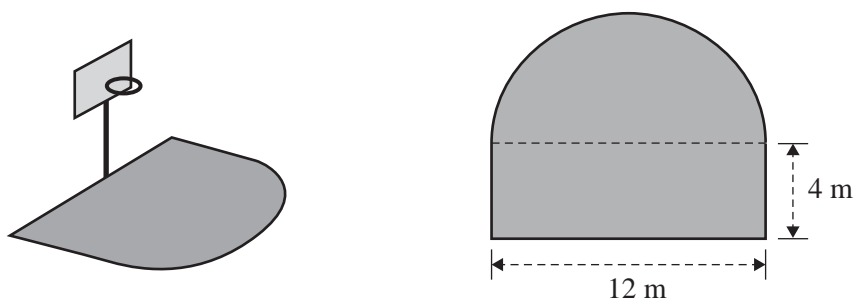

A boundary line is painted around the perimeter of the shape.

The total length of the boundary line, in metres, is closest to

- A. 38.8
- B. 57.7
- C. 66.8
- D. 76.5
- E. 85.7

Question 3

The lengths of the sides of a triangle are 3 cm, 6 cm and 5 cm, as shown below.

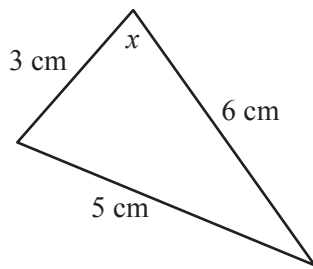

The angle, x , can be found using

A. $\cos(x) = \frac{3^2 + 6^2 - 5^2}{2 \times 3 \times 6}$

B. $\cos(x) = \frac{3^2 + 6^2 + 5^2}{2 \times 3 \times 6}$

C. $\cos(x) = \frac{3^2 + 5^2 - 6^2}{2 \times 3 \times 6}$

D. $\cos(x) = \frac{3}{5}$

E. $\cos(x) = \frac{3}{6}$

Question 4

Town A is due west of town B.

Town C is due south of town B.

The bearing of town A from town C is

- A. between 000° and 090°
- B. between 090° and 180°
- C. exactly 135°
- D. between 180° and 270°
- E. between 270° and 360°

Question 5

A company logo is in the shape of a regular hexagon with side length 2 cm, as shown below.

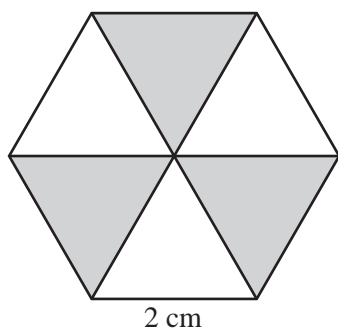

The hexagon is divided into six equilateral triangles. Every second triangle is shaded.

The shaded area of the logo, in square centimetres, is closest to

- A. 1.7
- B. 2.0
- C. 5.2
- D. 6.0
- E. 10.4

Question 6

A cylindrical block of wood has a diameter of 12 cm and a height of 8 cm.

A hemisphere is removed from the top of the cylinder, 1 cm from the edge, as shown below.

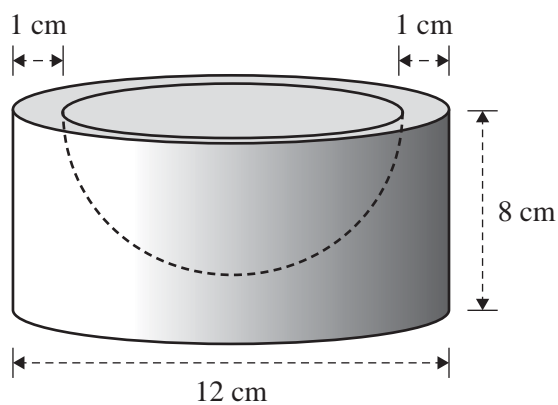

The volume of the block of wood, in cubic centimetres, after the hemisphere has been removed is closest to

- A. 452
- B. 606
- C. 643
- D. 1167
- E. 1357

Question 7

A 50 cent coin has 12 sides of equal length.

Two 50 cent coins are balanced next to each other on a table so that they meet along one edge, as shown below.

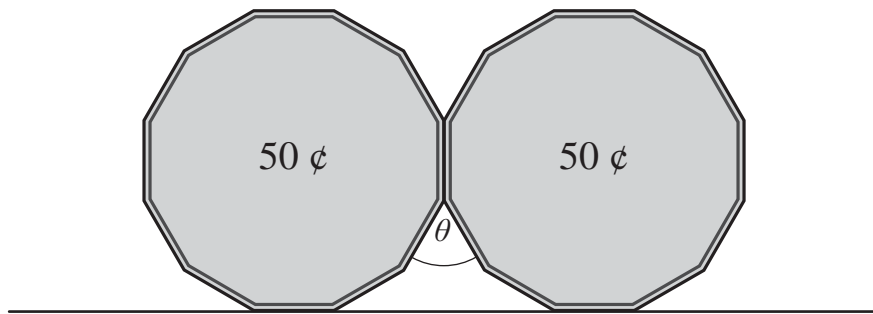

The angle, θ , is

- A. 12°
- B. 30°
- C. 36°
- D. 60°
- E. 72°

Question 8

A composite shape is made up of a parallelogram and a triangle, as shown below.

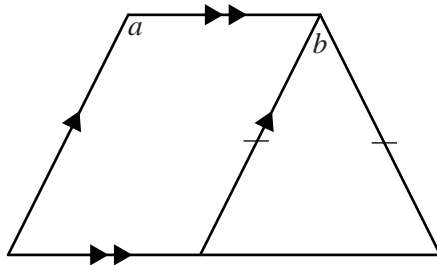

Which one of the following is **always true**?

- A. $b = 2a$
- B. $a = 2b$
- C. $a + b = 180$
- D. $a + 2b = 180$
- E. $2a - b = 180$

Question 9

A wedge of cheese is in the shape of a triangular prism.

The base of the wedge of cheese is 8 cm long, as shown below.

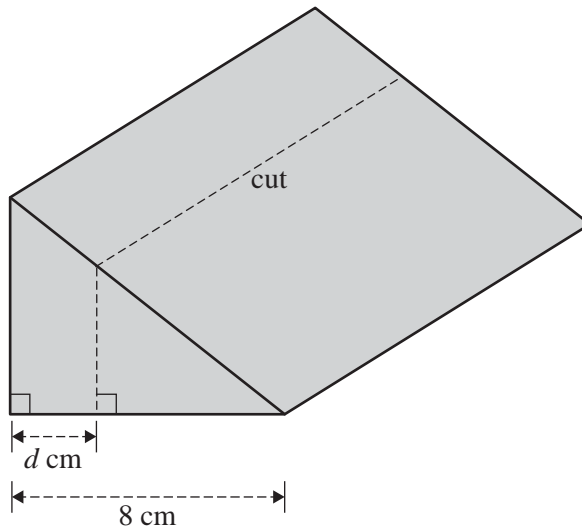

A smaller, similar wedge of cheese is cut from the larger wedge of cheese, as shown in the diagram.

The cut is made at a distance of d cm from the back edge of the larger wedge.

The volume of the smaller wedge is half the volume of the larger wedge.

The value of d , in centimetres, is closest to

- A. 1.7
- B. 2.3
- C. 4.0
- D. 5.7
- E. 6.3

Module 3: Graphs and relations

Before answering these questions you must **shade** the Graphs and relations box on the answer sheet for multiple-choice questions and write the name of the module in the box provided.

Question 1

A camera is accidentally dropped from the top of a tower that is 96 m high.

The graph below shows how the height of the camera above the ground, in metres, changes with time, in seconds.

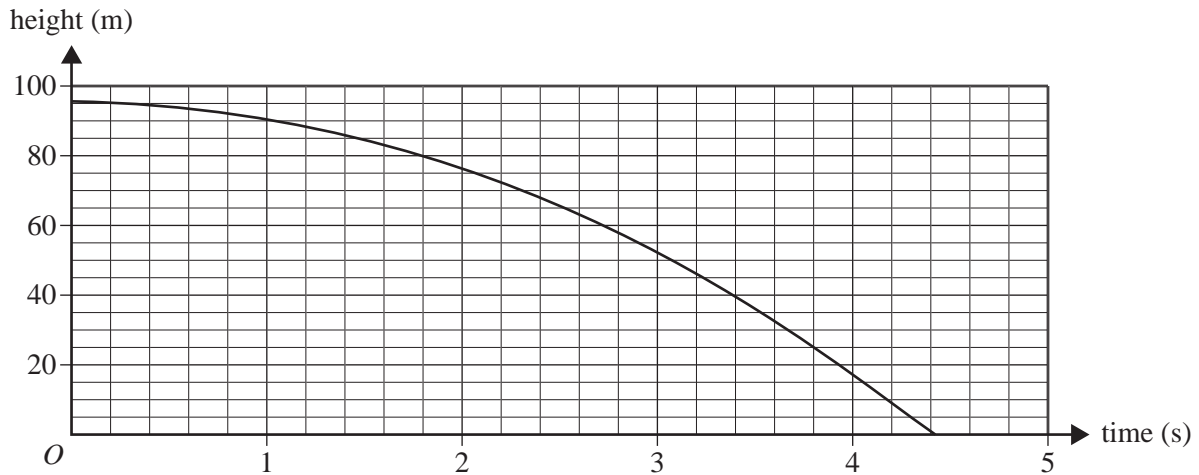

From the moment it was dropped, the time that it takes for the camera to hit the ground, in seconds, is closest to

- A. 4.2
- B. 4.4
- C. 4.9
- D. 6.0
- E. 9.6

Question 2

A point that satisfies the inequality $3x - 2y \geq 12$ is

- A. (1, 5)
- B. (2, 4)
- C. (3, 3)
- D. (4, 2)
- E. (5, 1)

Question 3

A local supermarket delivers groceries that are ordered online by its customers.

The graph below is used to determine the delivery fee from the amount spent by the customer.

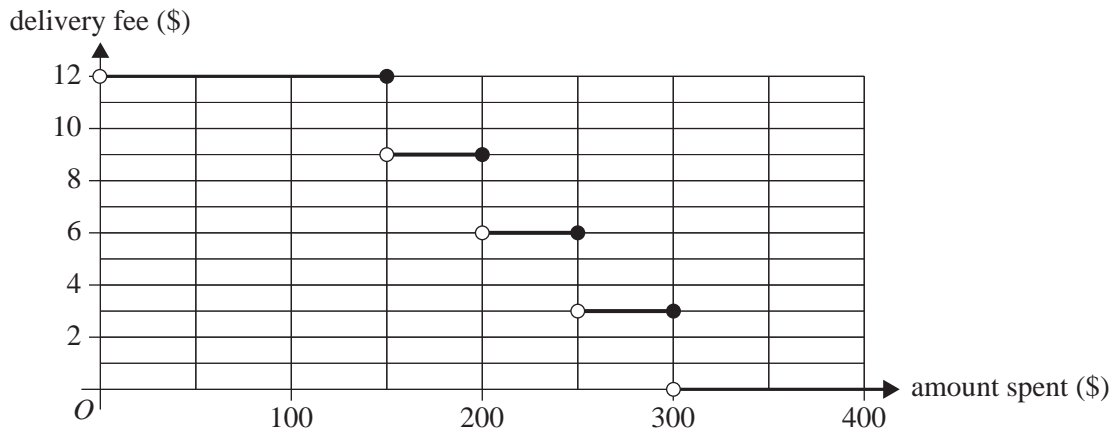

The delivery fee for an online customer who spends \$250 on groceries is

- A. \$3.00
- B. \$4.50
- C. \$6.00
- D. \$7.50
- E. \$9.00

Question 4

A straight line is graphed below.

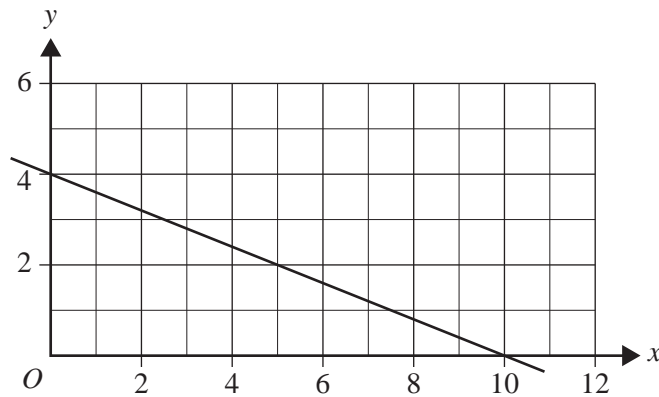

An equation for this straight line is

- A. $2x + 5y = 20$
- B. $10x + 4y = 20$
- C. $2x - 5y = 20$
- D. $5x + 2y = 20$
- E. $4x - 10y = 20$

Question 5

For an overnight school excursion there must be at least one teacher for every 15 students.

Let x be the number of students
 y be the number of teachers.

The inequality for this constraint is

- A. $y \geq 15$
- B. $x \leq 15$
- C. $y \geq 15x$
- D. $y \geq \frac{x}{15}$
- E. $x \geq \frac{y}{15}$

Question 6

The graph below shows the braking distance, in metres, of a car at different speeds, in kilometres per hour.

The coordinates of a point on the graph are also shown.

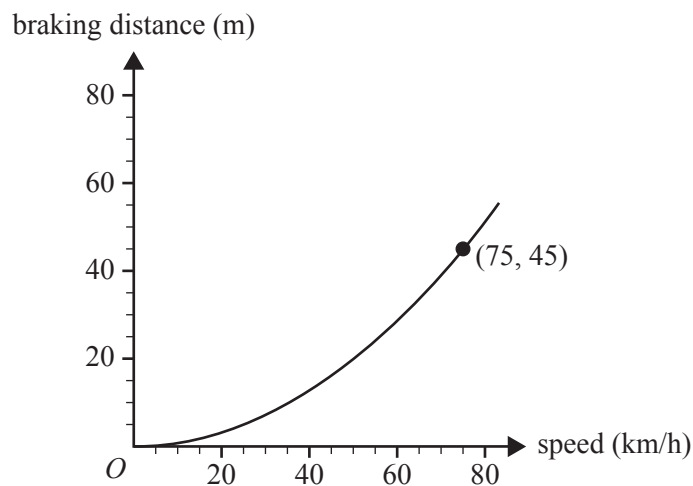

The relationship between *braking distance* and *speed* can be modelled by an equation of the form

$$\text{braking distance} = k \times (\text{speed})^2$$

Using this model, the braking distance, in metres, when the speed is 60 km/h is

- A. 24.0
- B. 28.8
- C. 30.0
- D. 32.2
- E. 48.5

Question 7

The graph below shows the cost, C , of printing n wedding invitations.

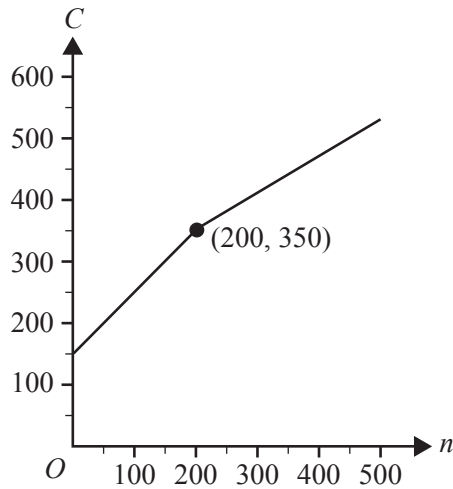

A function that can be used to model this is

$$C = \begin{cases} n + 150 & 0 \leq n < 200 \\ 0.6n + p & 200 \leq n \leq 500 \end{cases}$$

The value of p is

- A. 30
- B. 150
- C. 230
- D. 380
- E. 470

Question 8

To raise funds, a club plans to sell lunches at a weekend market.

The club will pay \$190 to rent a stall.

Each lunch will cost \$12 to prepare and will be sold for \$35.

To make a profit of at least \$1000, the minimum number of lunches that must be sold is

- A. 22
- B. 35
- C. 36
- D. 51
- E. 52

Question 9

The shaded area in the graph below shows the feasible region for a linear programming problem.

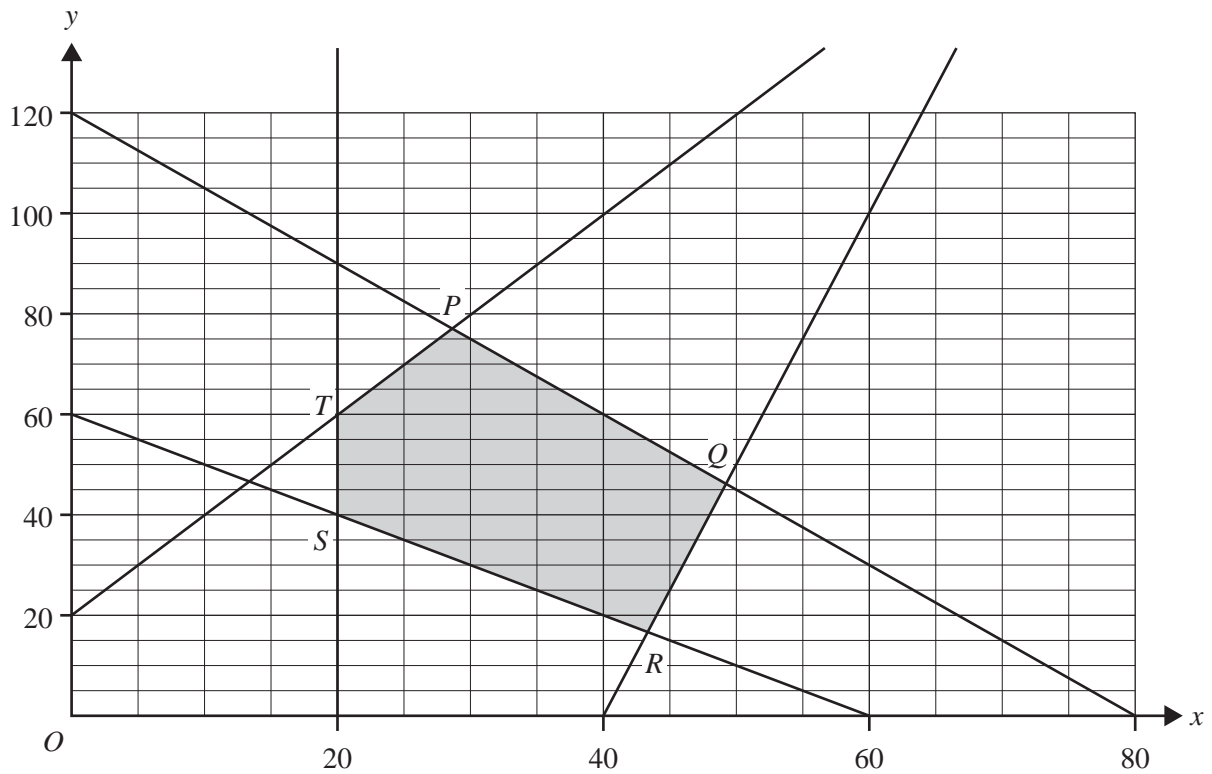

The maximum value of the objective function $Z = 4x - 3y$ for this problem occurs at point

- A. P
- B. Q
- C. R
- D. S
- E. T

Module 4: Business-related mathematics

Before answering these questions you must **shade** the Business-related mathematics box on the answer sheet for multiple-choice questions and write the name of the module in the box provided.

Question 1

Fong's gas bill is \$368.40. If he pays this bill on time, it will be reduced by 5%.

In this case, the bill would be reduced by

- A. \$1.84
- B. \$5.00
- C. \$18.42
- D. \$184.20
- E. \$349.98

Question 2

An investment property was purchased for \$600 000.

Over a 10-year period, its value increased to \$850 000.

The increase in value, as a percentage of the purchase price, is closest to

- A. 4.2%
- B. 25.0%
- C. 29.4%
- D. 41.7%
- E. 70.6%

Question 3

The closing price of a share on Wednesday was \$160.

The closing price of the same share on Thursday was 3% less than its closing price on Wednesday.

The closing price of the same share on Friday was 4.5% more than its closing price on Thursday.

The closing price of the share on Friday is closest to

- A. \$157.38
- B. \$161.98
- C. \$162.18
- D. \$162.40
- E. \$172.22

Question 4

Mary invests \$1200 for two years.

Interest is calculated at the rate of 3.35% per annum, compounding monthly.

The amount of interest she earns in two years is closest to

- A. \$6.71
- B. \$40.82
- C. \$80.40
- D. \$81.75
- E. \$83.03

Question 5

The purchase price of a car is \$20 000.

A deposit of \$5000 is paid.

The balance will be repaid with 60 monthly repayments of \$400.

The total amount of interest charged is

- A. \$1000
- B. \$4000
- C. \$9000
- D. \$19 000
- E. \$24 000

Question 6

The transaction details for a savings account for the month of August 2014 are shown in the table below.

The table is incomplete.

Date	Details	Deposit	Withdrawal	Balance
01 Aug. 2014	Brought forward			5120.50
10 Aug. 2014	Purchase		250.00	4870.50
17 Aug. 2014	Cheque	1000.00		5870.50
30 Aug. 2014	Interest			5885.72

Interest is calculated and paid monthly on the minimum balance for that month.

The annual rate of interest paid on this account is closest to

- A. 3.10%
- B. 3.11%
- C. 3.57%
- D. 3.75%
- E. 14.9%

Question 7

The following graph shows the depreciating value of a van.

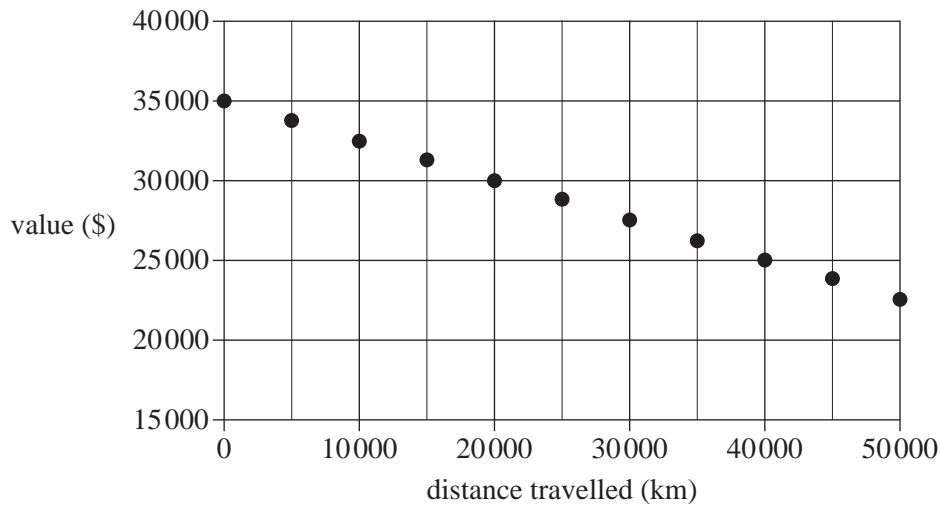

The graph could represent the van being depreciated using

- A. flat rate depreciation with an initial value of \$35 000 and a depreciation rate of \$25 per year.
- B. flat rate depreciation with an initial value of \$35 000 and a depreciation rate of 25 cents per year.
- C. reducing balance depreciation with an initial value of \$35 000 and a depreciation rate of 2.5% per annum.
- D. unit cost depreciation with an initial value of \$35 000 and a depreciation rate of 25 cents per kilometre travelled.
- E. unit cost depreciation with an initial value of \$35 000 and a depreciation rate of \$25 per kilometre travelled.

Question 8

Cindy took out a reducing balance loan of \$8400 to finance an overseas holiday.

Interest was charged at a rate of 9% per annum, compounding quarterly.

Her loan is to be fully repaid in six years, with equal quarterly payments.

After three years, Cindy will have reduced the balance of her loan by approximately

- A. 9%
- B. 35%
- C. 43%
- D. 50%
- E. 57%

Question 9

Ravi borrowed \$160 000 at an interest rate of 6.18% per annum.

Interest is calculated monthly on the reducing balance of the loan.

The loan will be fully repaid with monthly payments of \$1950.

Which one of the following statements is **not** true?

- A. His first payment reduces the loan by less than \$1950.
- B. His second payment reduces the loan by more than the first payment.
- C. Repaying more than \$1950 per month will reduce the term of the loan.
- D. His final payment will be less than \$1760.
- E. His final payment includes interest.

Module 5: Networks and decision mathematics

Before answering these questions you must **shade** the Networks and decision mathematics box on the answer sheet for multiple-choice questions and write the name of the module in the box provided.

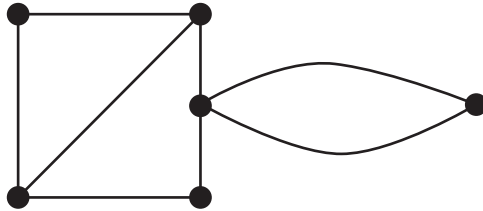
Question 1

In the graph above, the number of vertices of odd degree is

- A. 0
- B. 1
- C. 2
- D. 3
- E. 4

Question 2

A planar graph has five vertices and six faces.

The number of edges is

- A. 3
- B. 6
- C. 9
- D. 11
- E. 13

Question 3

The plan shows the layout of a section of pipes, drawn in bold lines, that supplies water to nine houses in a new estate.

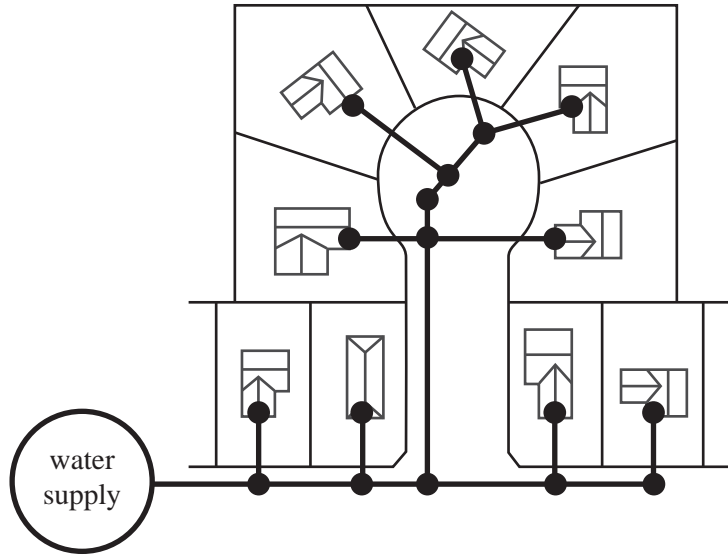

Which one of the following types of graph could be used to represent the layout of water pipe connections to the water supply and these houses?

- A. a bipartite graph
- B. a complete graph
- C. a loop
- D. a Hamiltonian path
- E. a tree

Question 4

The arrows on the diagram below show the direction of the flow of waste through a series of pipelines from a factory to a waste dump.

The numbers along the edges show the number of megalitres of waste per week that can flow through each section of pipeline.

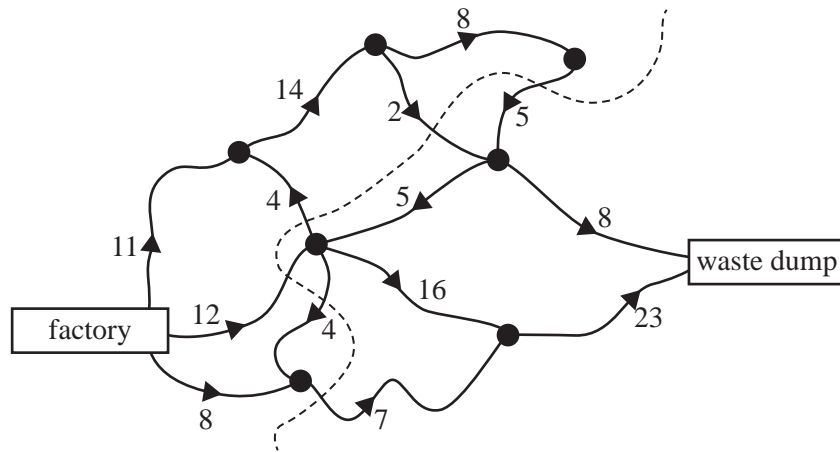

The minimum cut is shown as a dotted line.

The capacity of this cut, in megalitres of waste per week, is

- A. 6
- B. 18
- C. 26
- D. 32
- E. 34

Question 5

The graph below represents a friendship network. The vertices represent the four people in the friendship network: Kwan (K), Louise (L), Milly (M) and Narelle (N).

An edge represents the presence of a friendship between a pair of these people. For example, the edge connecting K and L shows that Kwan and Louise are friends.

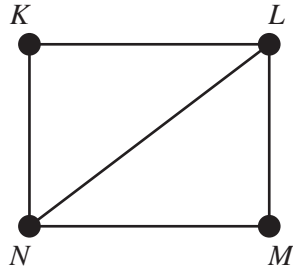

Which one of the following graphs does **not** contain the same information?

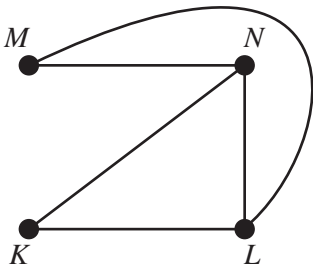
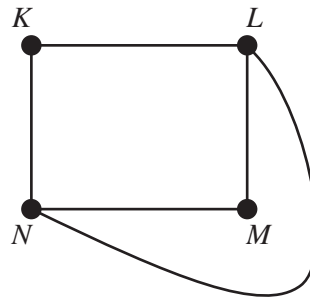
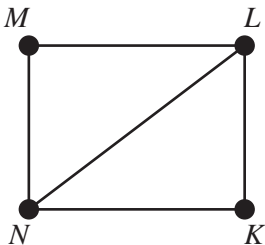
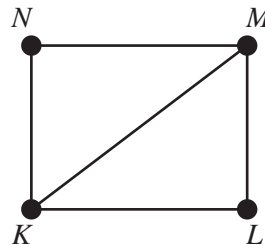
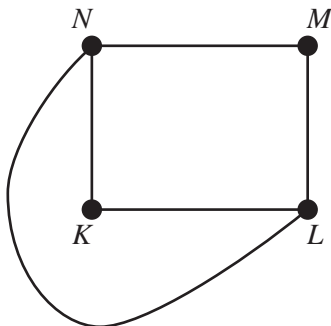
A.**B.****C.****D.****E.**

Question 6

The map below shows all road connections between five towns, U , V , W , X and Y .

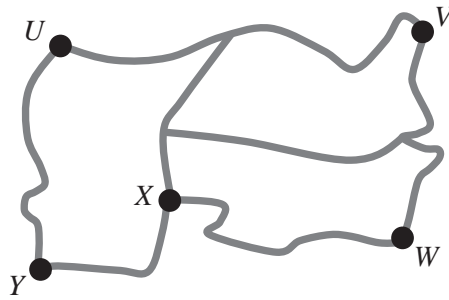

A graph, shown below, was constructed to represent this map.

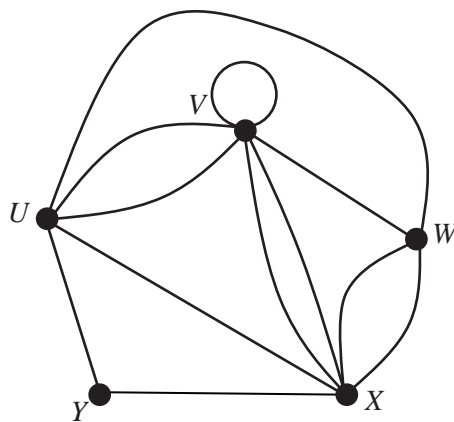

A mistake has been made in constructing this graph.

This mistake can be corrected by

- A. drawing another edge between V and W .
- B. drawing a loop at W .
- C. removing the loop at V .
- D. removing one edge between U and V .
- E. removing one edge between X and V .

Question 7

Four people, Abe, Bailey, Chris and Donna, are each to be allocated one of four tasks. Each person can complete each of the four tasks in a set time. These times, in minutes, are shown in the table below.

	Abe	Bailey	Chris	Donna
Task 1	80	100	95	90
Task 2	95	95	100	90
Task 3	125	125	125	120
Task 4	60	60	75	65

If each person is allocated a different task, the minimum total time for these four people to complete these four tasks is

- A. 260 minutes
- B. 355 minutes
- C. 360 minutes
- D. 365 minutes
- E. 375 minutes

Question 8

There are five teams in a table tennis competition.

Every team played one match against every other team, and each match had a winner and a loser.

The results of the matches are summarised in the directed graph below. For example, an arrow from Lions to Eagles indicates that Lions defeated Eagles.

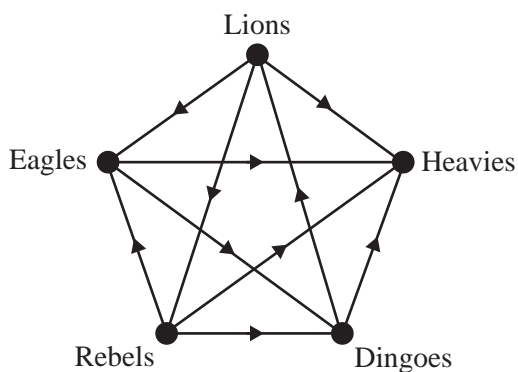

In determining the ranking of these teams, the total of each team's one-step dominances and two-step dominances will be calculated.

The team with the highest total will be ranked first.

The team with the next highest total will be ranked second, and so on.

The ranking of these five teams from first to last is

- A. Lions, Rebels, Dingoes, Eagles, Heavies
- B. Lions, Rebels, Eagles, Dingoes, Heavies
- C. Rebels, Lions, Dingoes, Eagles, Heavies
- D. Rebels, Lions, Eagles, Dingoes, Heavies
- E. Eagles, Lions, Rebels, Dingoes, Heavies

Question 9

The table below shows, in minutes, the duration, the earliest starting time (EST) and the latest starting time (LST) of eight activities needed to complete a project.

Activity	Duration	EST	LST
<i>A</i>	5	0	0
<i>B</i>	3	5	5
<i>C</i>	6	5	6
<i>D</i>	5	8	9
<i>E</i>	4	8	8
<i>F</i>	6	12	12
<i>G</i>	4	13	14
<i>H</i>	3	18	18

Which one of the following directed graphs shows the sequence of these activities?

- A.**
- B.**
- C.**
- D.**
- E.**

Module 6: Matrices

Before answering these questions you must **shade** the Matrices box on the answer sheet for multiple-choice questions and write the name of the module in the box provided.

Question 1

Matrix B below shows the number of photography (P), art (A) and cooking (C) books owned by Steven (S), Trevor (T), Ursula (U), Veronica (V) and William (W).

$$B = \begin{array}{ccccc} & P & A & C & \\ \begin{array}{c} S \\ T \\ U \\ V \\ W \end{array} & \begin{bmatrix} 8 & 5 & 4 \\ 1 & 4 & 5 \\ 3 & 3 & 4 \\ 4 & 2 & 2 \\ 1 & 4 & 1 \end{bmatrix} & & & \end{array}$$

The element in row i and column j of matrix B is b_{ij} .

The element b_{32} is the number of

- A. art books owned by Trevor.
- B. art books owned by Ursula.
- C. art books owned by Veronica.
- D. cooking books owned by Ursula.
- E. cooking books owned by Trevor.

Question 2

Four matrices are shown below.

$$W = \begin{bmatrix} 3 \\ 6 \\ 2 \end{bmatrix} \quad X = \begin{bmatrix} 4 & 1 & 5 \\ 2 & 0 & 6 \end{bmatrix} \quad Y = [7 \quad 1] \quad Z = \begin{bmatrix} 8 & 5 & 0 \\ 1 & 9 & 3 \\ 4 & 2 & 7 \end{bmatrix}$$

Which one of the following matrix products is **not** defined?

- A. $W \times Y$
- B. $X \times W$
- C. $Y \times X$
- D. $Z \times W$
- E. $Z \times Y$

Question 3

Four systems of simultaneous linear equations are shown below.

$$\begin{array}{cccc} 12x + 8y = 26 & 3x - 2y = 14 & -4x - 2y = 17 & x + 0.5y = 8 \\ 3x + 2y = 15 & -7x + 5y = 9 & -6x + 3y = 10 & 0.5x + y = 8 \end{array}$$

How many of these systems of simultaneous linear equations do **not** have a unique solution?

- A. 0
- B. 1
- C. 2
- D. 3
- E. 4

Question 4

The numbers of adult and child tickets purchased for five performances of a stage show are shown in the table below.

Performance	Adult	Child
1	142	24
2	128	31
3	89	24
4	104	18
5	115	23

Which one of the following matrix calculations can be used to determine both the total number of adult tickets and the total number of child tickets purchased for all five performances?

- A. $\begin{bmatrix} 1 \\ 1 \\ 1 \\ 1 \\ 1 \\ 1 \end{bmatrix} \begin{bmatrix} 142 & 128 & 89 & 104 & 115 \\ 24 & 31 & 24 & 18 & 23 \end{bmatrix}$
- B. $\begin{bmatrix} 1 & 1 \\ 1 & 1 \\ 1 & 1 \\ 1 & 1 \\ 1 & 1 \end{bmatrix} \begin{bmatrix} 142 & 128 & 89 & 104 & 115 \\ 24 & 31 & 24 & 18 & 23 \end{bmatrix}$
- C. $\begin{bmatrix} 142 & 128 & 89 & 104 & 115 \\ 24 & 31 & 24 & 18 & 23 \end{bmatrix} \begin{bmatrix} 1 & 1 & 1 & 1 & 1 \\ 1 & 1 & 1 & 1 & 1 \end{bmatrix}$
- D. $\begin{bmatrix} 1 & 1 \end{bmatrix} \begin{bmatrix} 142 & 128 & 89 & 104 & 115 \\ 24 & 31 & 24 & 18 & 23 \end{bmatrix}$
- E. $\begin{bmatrix} 142 & 128 & 89 & 104 & 115 \\ 24 & 31 & 24 & 18 & 23 \end{bmatrix} \begin{bmatrix} 1 \\ 1 \\ 1 \\ 1 \\ 1 \end{bmatrix}$

Question 5

Wendy buys one type of flower each day.

She chooses from tulips (T), roses (R), carnations (C), irises (I) and daisies (D).

The type of flower she buys on one day depends on the type of flower she bought the previous day, according to a transition matrix.

Today, Wendy bought tulips.

The transition matrix that, starting tomorrow, ensures Wendy buys flowers in alphabetical order (C, D, I, R, T) is

A. today

T	R	C	I	D	
0	1	0	0	0	T
0	0	0	0	1	R
1	0	0	0	0	C tomorrow
0	0	1	0	0	I
0	0	0	1	0	D

B. today

T	R	C	I	D	
0	0	0	0	1	T
0	0	1	0	0	R
1	0	0	0	0	C tomorrow
0	1	0	0	0	I
0	0	0	1	0	D

C. today

T	R	C	I	D	
0	0	0	0	1	T
0	0	0	1	0	R
1	0	0	0	0	C tomorrow
0	0	1	0	0	I
0	1	0	0	0	D

D. today

T	R	C	I	D	
0	1	0	0	0	T
0	0	0	1	0	R
1	0	0	0	0	C tomorrow
0	0	0	0	1	I
0	0	1	0	0	D

E. today

T	R	C	I	D	
0	0	0	1	0	T
0	0	0	0	1	R
1	0	0	0	0	C tomorrow
0	1	0	0	0	I
0	0	1	0	0	D

Question 6

A carpenter can make four coffee tables and seven stools in a total of 33 hours.

The carpenter can make two coffee tables and three pencil boxes in a total of 12 hours.

The carpenter can make five stools and one pencil box in a total of 10 hours.

The time, in hours, that it takes to make one coffee table is closest to

- A.** 2
- B.** 3
- C.** 4
- D.** 5
- E.** 6

Question 7

Matrix P has inverse matrix P^{-1} .

Matrix P is multiplied by the scalar w ($w \neq 0$) to form matrix Q .

Matrix Q^{-1} is equal to

- A. $\frac{1}{w}P^{-1}$
- B. $\frac{1}{w^2}P^{-1}$
- C. wP^{-1}
- D. w^2P^{-1}
- E. P^{-1}

Question 8

The order of matrix X is 2×3 .

The element in row i and column j of matrix X is x_{ij} and it is determined by the rule

$$x_{ij} = i - j$$

Which one of the following calculations would result in matrix X ?

- A. $\begin{bmatrix} 1 & 1 & 1 \\ 2 & 2 & 2 \end{bmatrix} - \begin{bmatrix} 1 & 2 & 3 \\ 1 & 2 & 3 \end{bmatrix}$
- B. $\begin{bmatrix} 1 & 2 & 3 \\ 1 & 2 & 3 \end{bmatrix} - \begin{bmatrix} 1 & 1 & 1 \\ 2 & 2 & 2 \end{bmatrix}$
- C. $\begin{bmatrix} 2 & 2 & 2 \\ 2 & 2 & 2 \end{bmatrix} - \begin{bmatrix} 3 & 3 & 3 \\ 3 & 3 & 3 \end{bmatrix}$
- D. $\begin{bmatrix} 1 & 2 \\ 1 & 2 \\ 1 & 2 \end{bmatrix} - \begin{bmatrix} 1 & 1 \\ 2 & 2 \\ 3 & 3 \end{bmatrix}$
- E. $\begin{bmatrix} 1 & 1 \\ 2 & 2 \\ 3 & 3 \end{bmatrix} - \begin{bmatrix} 1 & 2 \\ 1 & 2 \\ 1 & 2 \end{bmatrix}$

Question 9

A fast-food stand at the football sells pies (P) and chips (C).

Each week, 300 customers regularly buy either a pie or chips, but not both, from this stand.

For the first five weeks, the customers' choice of pie or chips is expected to change weekly according to the transition matrix T_1 , where

$$T_1 = \begin{array}{c} \text{this week} \\ \begin{array}{cc} P & C \end{array} \\ \left[\begin{array}{cc} 0.65 & 0.25 \\ 0.35 & 0.75 \end{array} \right] \begin{array}{c} P \\ C \end{array} \text{ next week} \end{array}$$

After the first five weeks, due to expected cold weather, the customers' choice of pie or chips is expected to change weekly according to the transition matrix T_2 , where

$$T_2 = \begin{array}{c} \text{this week} \\ \begin{array}{cc} P & C \end{array} \\ \left[\begin{array}{cc} 0.85 & 0.25 \\ 0.15 & 0.75 \end{array} \right] \begin{array}{c} P \\ C \end{array} \text{ next week} \end{array}$$

In week 1, 150 customers bought a pie and 150 customers bought chips.

Let S_1 be the state matrix for week 1.

The number of customers expected to buy a pie or chips in week 8 can be found by evaluating

- A. $T_2^7 S_1$
- B. $T_1^8 S_1$
- C. $T_2^3 (T_1^4 S_1)$
- D. $T_1^3 (T_2^4 S_1)$
- E. $T_1^3 (T_2^5 S_1)$

FURTHER MATHEMATICS

Written examinations 1 and 2

FORMULA SHEET

Instructions

Detach this formula sheet during reading time.

This formula sheet is provided for your reference.

Further Mathematics formulas

Core: Data analysis

standardised score:
$$z = \frac{x - \bar{x}}{s_x}$$

least squares regression line:
$$y = a + bx, \quad \text{where } b = r \frac{s_y}{s_x} \quad \text{and} \quad a = \bar{y} - b\bar{x}$$

residual value:
$$\text{residual value} = \text{actual value} - \text{predicted value}$$

seasonal index:
$$\text{seasonal index} = \frac{\text{actual figure}}{\text{deseasonalised figure}}$$

Module 1: Number patterns

arithmetic series:
$$a + (a + d) + \dots + (a + (n - 1)d) = \frac{n}{2}[2a + (n - 1)d] = \frac{n}{2}(a + l)$$

geometric series:
$$a + ar + ar^2 + \dots + ar^{n-1} = \frac{a(1 - r^n)}{1 - r}, \quad r \neq 1$$

infinite geometric series:
$$a + ar + ar^2 + ar^3 + \dots = \frac{a}{1 - r}, \quad |r| < 1$$

Module 2: Geometry and trigonometry

area of a triangle:
$$\frac{1}{2}bc \sin A$$

Heron's formula:
$$A = \sqrt{s(s - a)(s - b)(s - c)}, \quad \text{where } s = \frac{1}{2}(a + b + c)$$

circumference of a circle:
$$2\pi r$$

area of a circle:
$$\pi r^2$$

volume of a sphere:
$$\frac{4}{3}\pi r^3$$

surface area of a sphere:
$$4\pi r^2$$

volume of a cone:
$$\frac{1}{3}\pi r^2 h$$

volume of a cylinder:
$$\pi r^2 h$$

volume of a prism:
$$\text{area of base} \times \text{height}$$

volume of a pyramid:
$$\frac{1}{3} \text{area of base} \times \text{height}$$

Pythagoras' theorem: $c^2 = a^2 + b^2$

sine rule: $\frac{a}{\sin A} = \frac{b}{\sin B} = \frac{c}{\sin C}$

cosine rule: $c^2 = a^2 + b^2 - 2ab \cos C$

Module 3: Graphs and relations

Straight-line graphs

gradient (slope): $m = \frac{y_2 - y_1}{x_2 - x_1}$

equation: $y = mx + c$

Module 4: Business-related mathematics

simple interest: $I = \frac{PrT}{100}$

compound interest: $A = PR^n$, where $R = 1 + \frac{r}{100}$

hire-purchase: effective rate of interest $\approx \frac{2n}{n+1} \times \text{flat rate}$

Module 5: Networks and decision mathematics

Euler's formula: $v + f = e + 2$

Module 6: Matrices

determinant of a 2×2 matrix: $A = \begin{bmatrix} a & b \\ c & d \end{bmatrix}$; $\det A = \begin{vmatrix} a & b \\ c & d \end{vmatrix} = ad - bc$

inverse of a 2×2 matrix: $A^{-1} = \frac{1}{\det A} \begin{bmatrix} d & -b \\ -c & a \end{bmatrix}$ where $\det A \neq 0$